

SANMOTION

AC SERVO SYSTEMS

R

TYPE S

Analog/Pulse Input Type

For Rotary Motor

Instruction Manual

SANYODENKI

Preface

This product corresponds with the shipping regulations given in the Export Trade Control Ordinance (Table 1, item 16) and the Foreign Exchange Ordinance (Table 1, item 16). When these products are exported by customers, and when exported including the other freight or together with other freight, it is recommended to fulfill the requirements related to Security Export Control with the relevant authorities, including “Information Requirements” and “Objective Requirements”.

This manual outlines the functions, wiring, installation, operations, maintenance, specifications, etc. of the AC servo amplifier “R” Series Type S. The “R” Series Type S AC servo amplifier system is compatible with a wide variety of various applications requiring low, medium or high capacity, high efficiency, reduced footprint, and excellent cost performance.

This product was developed to offer a series of servo motors that are easy to use and offer excellent functionality in an AC servo motor. It fulfills various needs, such as the downsizing of the control panel, and offers compatibility for a wide range of applications requiring a servo motor.

★Precautions related to this Instruction Manual

- In order to fully understand the functions of AC servo amplifier “R” Series Type S, please read this instruction manual thoroughly before using it.
- After reading this manual thoroughly, please keep it handy for reference.
- Please contact the dealer or sales representative if there are defects such as nonconsecutive pages, missing pages or if the manual is lost or damaged.
- Carefully and completely follow the safety instructions outlined in this manual. Please note that safety is not guaranteed for usage methods other than those specified in this manual or usage methods intended for the original product.
- The contents of this manual may be modified without prior notice, as revisions or additions are made in the usage method of this product. Modifications are performed per the revisions of this manual.
- Permission is granted to reproduce or omit part of the attached figures (as abstracts) for use.
- Although the manufacturer has taken all possible measures to ensure the veracity of the contents of this manual, if you should notice any error or omission, please notify the dealer or sales office of the finding.

【Safety Precautions】

This chapter is a summary of the safety precautions regarding the use of the R-series type-S amplifier. Please read this entire manual carefully prior to installing, operating, performing maintenance or inspecting this device to ensure proper use.

Use this device only after learning about its operation, safety information, and the precautions related to its use. After reading the User Manual, keep it in a location where it is always available to the user for easy reference.

The R-series servo amplifiers and servo motors were designed for use with general industrial equipment. The following instructions should be followed:









- Read the User Manual carefully before any installation or assembly work to ensure proper use.
- Do not perform any retrofitting or modification of the product.
- Consult with your sale representatives or a trained professional technician regarding the installation and maintenance of these devices.
- Please contact your distributor or sales office if you intend to use these devices in applications such as;
 - * In medical instruments or systems used for life support;
 - * With control systems for trains or elevators, the failure of which could cause bodily injury;
 - * In computer systems of social or public importance;
 - * In other equipment or systems related to human safety or public infrastructure.
- Additionally, please contact your distributor or sales office if the device is to be used in an environment where vibration is present, such as in-vehicle or transport applications.

Safety Precautions







[Make sure to follow]

This documentation uses the following annotation. Make sure to strictly follow these safety precautions.

■ Safety Precautions and symbols

Safety Precautions		symbols	
Danger	Denotes immediate hazards that will probably cause severe bodily injury or death as a result of incorrect operation.		Danger /Injury
			Electric shock
Caution	Denotes hazards that could cause bodily injury and product or property damage as a result of incorrect operation. Even those hazards denoted by this symbol could lead to a serious accident.		Caution
			Fire
			Burn
Prohibited	Indicates actions that must not be allowed to occur prohibited actions.		Prohibited
			Disassembly prohibited
Mandatory	Indicates actions that must be carried out (mandatory actions).		Mandatory

 **Danger**





<p>Do not use this device in explosive environment.</p> <p> Injury or fire could otherwise result.</p>	<p>Do not touch the inside of the amplifier.</p> <p> Electric shock could otherwise result.</p>
<p>Do not perform any wiring, maintenance or inspection when the device is hot-wired. After switching the power off, wait at least 5 minutes before performing these tasks.</p> <p> Electric shock could otherwise result.</p>	<p>Only technically qualified personnel should transport, install, wire, operate, or perform maintenance and inspection on this device.</p> <p> Electric shock, injury or fire could otherwise result.</p>
<p>The protective ground terminal (⊕) should always be grounded to the control box or equipment. The ground terminal of the motor should always be connected to the protective ground terminal (⊕) of the amplifier.</p> <p> Electric shock could otherwise result.</p>	<p>Do not damage the cable, do not apply unreasonable stress to it, do not place heavy items on it, and do not insert it in between objects.</p> <p> Electric shock could otherwise result.</p>

Safety Precautions

[Make sure to follow]









Danger















<p>Wiring should be done based on the wiring diagram or the user manual.</p> <p> Electric shock or fire could otherwise result.</p>	<p>Do not touch the rotating part of the motor during operation.</p> <p> Bodily injury could otherwise result.</p>
<p>Do not touch or get close to the terminal and the connector while the device is powered up.</p> <p> Electric shock could otherwise result.</p>	<p>Do not unplug the terminal and the connector while the device is powered up.</p> <p> Electric shock could otherwise result.</p>















Caution

<p>Please read the User Manual carefully before installation, operation, maintenance or inspection, and perform these tasks according to the instructions.</p> <p> Electric shock, injury or fire could otherwise result.</p>	<p>Do not use the amplifier or the motor outside their specifications.</p> <p> Electric shock, injury or damage to the device could otherwise result.</p>
<p>Do not use the defective, damaged and burnt amplifier or the motor.</p> <p> Injury or fire could otherwise result.</p>	<p>Use the amplifier and motor together in the specified combination.</p> <p> Fire or damage to the device could otherwise result.</p>
<p>Be careful of the high temperatures generated by the amplifier/motor and the peripherals.</p> <p> Burn could otherwise result.</p>	<p>Open the box only after checking its top and bottom location.</p> <p> Bodily injury could otherwise result.</p>

Caution

<p>Verify that the products correspond to the order sheet/packing list. If the wrong product is installed, injury or damage could result.</p> <p> Injury or damage could result.</p>	<p>Do not impress static electricity, the high voltage, etc. to the cable for encoders of the servo motor.</p> <p> Damage to the device could otherwise result.</p>
<p>Do not measure the insulation resistance and the pressure resistance.</p> <p> Damage to the device could otherwise result.</p>	<p>Wiring should follow electric equipment technical standards and indoor wiring regulations.</p> <p> An electrical short or fire could otherwise result.</p>
<p>Wiring connections must be secure.</p> <p> Motor interruption or bodily injury could otherwise result.</p>	<p>Keep static electricity and high voltage away from the encoder terminals of the motor.</p> <p> Damage to the device could otherwise result.</p>
<p>Do not place heavy objects on top of it or stand on the device.</p> <p> Bodily injury could otherwise result.</p>	<p>Do not obstruct the air intake and exhaust vents, and keep them free of debris and foreign matter.</p> <p> Fire could otherwise result.</p>
<p>Make sure the mounting orientation is correct.</p> <p> Fire or damage to the device could otherwise result.</p>	<p>Put the distance according to the manual in the array in the control board of the servo amplifier.</p> <p> Damage to the device could otherwise result.</p>
<p>Do not subject the device to excessive shock or vibration.</p> <p> Damage to the device could otherwise result.</p>	<p>Secure the device against falling, overturning, or shifting inadvertently during installation.</p> <p> Use the hardware supplied with the motor (if applicable).</p>
<p>Do not expose the device to water, corrosive or flammable gases, or any flammable material.</p> <p> Fire or damage to the device could otherwise result.</p>	<p>Install the device on a metal or other non-flammable support.</p> <p> Fire could otherwise result.</p>

Caution





<p>There is no safeguard on the motor. Use an over-voltage safeguard, short-circuit breaker, overheating safeguard, and emergency stop to ensure safe operation.</p> <p> Injury or fire could otherwise result.</p>	<p>Do not touch the radiation fin of the amplifier, the regenerative resistor, or the motor while the device is powered up, or immediately after switching the power off, as these parts generate excessive heat.</p> <p> Burn could otherwise result.</p>
<p>In the case of any irregular operation, stop the device immediately.</p> <p> Electric shock, injury or fire could otherwise result.</p>	<p>Do not perform extensive adjustments to the device as they may result in unstable operation.</p> <p> Bodily injury could otherwise result.</p>
<p>Trial runs should be performed with the motor in a fixed position, separated from the mechanism. After verifying successful operation, install the motor on the mechanism.</p> <p> Bodily injury could otherwise result.</p>	<p>The holding brake is not to be used as a safety stop for the mechanism. Install a safety stop device on the mechanism.</p> <p> Bodily injury could otherwise result.</p>
<p>In the case of an alarm, first remove the cause of the alarm, and then verify safety. Next, reset the alarm and restart the device.</p> <p> Bodily injury could otherwise result.</p>	<p>Make sure the input power supply voltage is in or less than the specification range.</p> <p> Damage to the device could otherwise result</p>
<p>Avoid getting close to the device, as a momentary power outage could cause it to suddenly restart (although it is designed to be safe even in the case of a sudden restart).</p> <p> Bodily injury could otherwise result.</p>	<p>Standard specification servo amplifiers have a dynamic brake resistor. Do not rotate the motor continuously from the outside when the amplifier is not powered on, because the dynamic brake resistor will heat up, and can be dangerous.</p> <p> Fire or burn could otherwise result.</p>
<p>Be careful during maintenance and inspection, as the body of the amplifier becomes hot.</p> <p> Burn could otherwise result.</p>	<p>It is recommended to replace the electrolytic capacitors in the amplifier after 5 years, if used at an average temperature of 40°C year round.</p> <p> Damage to the device could otherwise result.</p>

Safety Precautions

[Make sure to follow]







Caution







<p>Please contact your distributor or sales office if repairs are necessary. Disassembly could render the device inoperative.</p> <p> Damage to the device could otherwise result.</p>	<p>Make sure the device does not fall, overturn, or move inadvertently during transportation.</p> <p> Bodily injury could otherwise result.</p>
<p>Do not hold the device by the cables or the shaft while handling it.</p> <p> Damage to the device or bodily injury could otherwise result.</p>	<p>If the amplifier or the motor is no longer in use, it should be discarded as industrial waste.</p> <p></p>



Prohibited

<p>Do not store the device where it could be exposed to rain, water, toxic gases or other liquids.</p> <p> Damage to the device could otherwise result.</p>	<p>The built-in brake is intended to secure the motor; do not use it for regular control. Damage to the brake could otherwise result.</p> <p> Damage to the device could otherwise result.</p>
<p>Do not overhaul the device.</p> <p> Fire or electric shock could otherwise result.</p>	<p>Do not remove the nameplate cover attached to the device.</p> <p></p>

Mandatory

<p>Avoid direct sunlight and keep it by temperature and humidity within the range of the specification. {-20°C to +65°C, below 90% RH (non-condensing)}.</p> <p></p>	<p>Please contact our office if the amplifier is to be stored for a period of 3 years or longer. The capacity of the electrolytic capacitors decreases during long-term storage, and could cause damage to the device.</p> <p> Damage to the device could otherwise result.</p>
<p>Install an external emergency stop circuit and enable it to stop the device and cut off the power supply immediately. Install an external protective circuit to the amplifier to cut off the power from the main circuit in the case of an alarm.</p> <p></p> <p>Motor interruption, bodily injury, burnout, fire and secondary damages could otherwise result.</p>	<p>Operate within the specified temperature and humidity range</p> <p>Amplifier: Temperature 0°C to 55°C, Humidity below 90% RH (non-condensing).</p> <p>Motor: Temperature 0°C to 40°C, Humidity below 90% RH (non-condensing).</p> <p> Burnout or damage to the device could otherwise result.</p>
<p>Follow the directions written on the outside box. Excess stacking could result in collapse.</p> <p> Bodily injury could otherwise result.</p>	<p>The motor angling bolts are used for transporting the motor. Do not use them for transporting the machinery, etc.</p> <p> Damage to the device or bodily injury could otherwise result.</p>

[Table of Contents]

[1 Prior to use]

Product Verification.....	1-1
Servo Motor Model Number.....	1-2
Servo Amplifier Model Number.....	1-4
Servo Amplifier Part Names.....	1-8
Servo Motor Part Names.....	1-10

[2 Installation]

Servo Amplifier	2-1
Mounting Direction and Location	2-3
Arrangement within the control box	2-3
Servo Motor	2-4
Waterproofing and Dust Proofing	2-5
Protective Cover Installation	2-5
Gear Installation.....	2-6
Integration with the Target Machinery	2-6
Allowable Bearing Load	2-8
Cable Installation Considerations	2-9

[3 Wiring]

Packaged Wiring Diagram	3-1
High Voltage Circuit/Name • Function • Terminal Number	3-5
Tightening Torque of High Voltage Circuit Terminal.....	3-6
Wiring Example of High Voltage Circuit • Protective Circuit	3-7
Description of CN Terminal/Low Voltage Circuit.....	3-11
Description of CN 1 Terminal/Low Voltage Circuit	3-12
Overall Wiring Diagram of CN1/Low Voltage Circuit	3-13
Wiring Example of CN1 Input Circuit/Low Voltage Circuit	3-15
Wiring Example of CN1 Output Circuit/Low Voltage Circuit	3-18
Wiring of CN2/Low Voltage Circuit	3-21
Power Source • Peripherals.....	3-26
Cable Diameter.....	3-28
How to Process CN1/CN2 Shield	3-30

[4 Digital operator]

Names and Functions	4-1
Various Modes.....	4-2
Changing Modes	4-3
Monitor Mode Operations and Display	4-4
Basic Parameter Mode Operations and Display.....	4-7
General Parameter Mode Operations and Display.....	4-9
Auto-adjustment Mode Operations and Display	4-11
Test Run Mode Operations and Display	4-12
System Parameter Mode Operations and Display	4-14
Alarm Trace/CPU_VER Operations and Display.....	4-15
Password Setting.....	4-16

[5 Description of parameters]

Parameter List	5-1
Parameter setting value 【Group0】	5-8
Parameter setting value 【Group1】	5-9
Parameter setting value 【Group2】	5-11
Parameter setting value 【Group3】	5-14
Parameter setting value 【Group4】 【Group8】	5-16
Parameter setting value 【Group9】	5-22
Parameter setting value 【GroupA】	5-24
Parameter setting value 【GroupB】	5-27
Parameter setting value 【GroupC】	5-30
System parameter setting value	5-32
Block Diagram	5-34

[6 Operations]

Procedure Prior to Operation.....	6-1
Confirmation of Installation and Wiring.....	6-3
Confirmation & Change of Servo Amplifier Specification	6-4
Confirmation & Change of Servo Motor Encoder Specification	6-5
Confirmation & Change of Servo Motor Model Number	6-6
JOG Operation	6-7
Confirmation of I/O Signal.....	6-8
Confirmation of Device Operation	6-9
Operation Sequence	6-10

[7 Adjustment • Functions]

Servo Gain Tuning	7-1
Functions of Group8.....	7-7
Functions of Group9.....	7-25
Functions of GroupB	7-31
Functions of GroupC.....	7-36
Description of monitor	7-39

[8 Maintenance]

Trouble Shooting	8-1
Alarm List.....	8-3
Trouble shooting when the Alarm Occurs.....	8-5
Inspection/Parts Overhaul	8-25

[9 Specifications]

Servo amplifier	9-1
Pulse output	9-4
Serial output	9-5
General servo motor	9-23
Rotation Direction Specifications	9-23
Mechanical specifications	9-24
Holding brake specifications	9-26

[Materials]

[Selection Details]

Acceleration time / Moderation time / Allowable repetition frequency	1
Loading Precautions	3
Attention to average rotational speed	3
Dynamic brake	4
Regenerative treatment / Regenerative electric power calculation / Confirmation of regenerative electric power	7
External regenerative resistor / Dimension	11

[International standards]

International standard conformity • Certificate number	18
Compliance with EC directives • Recommended prevention components	20

[Dimension]

Servo amplifier	24
Servo motor	30

[Servo motor data sheet]

Characteristics table	41
Velocity—Torque characteristics	47
Over load characteristics	56

[Options]

Connector • Communication cable	65
Metal mounting fittings	66
Monitor box	69
Lithium battery • EMC kit	70

[Encoder clear]

Clear • Reset method	71
----------------------------	----

[Electronic gear]

Usage	72
-------------	----

[Shortened model number]

Set-up contents	73
-----------------------	----

[Prior to Use]

◆	Product verification.....	1-1
◆	Servo motor model number	1-2
◆	Servo amplifier model number	1-4
◆	Servo amplifier part names	1-8
◆	Servo motor part names	1-10

1. Prior to Use

[Product verification]

- Verify the followings when the product arrives. If you find any discrepancy, contact your distributor or sales office.
 - Verify that the model number of the servo motor or servo amplifier is the same as ordered.
(The model number is located on the main name plate, following the word "MODEL".)
 - Make sure) that there is no problem on externals of the servo motor and the servo amplifier.
 - Verify that there are no loose screws on the servo motor or servo amplifier.

Servo motor

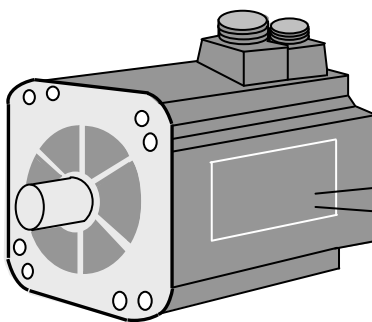

Servo amplifier main nameplate

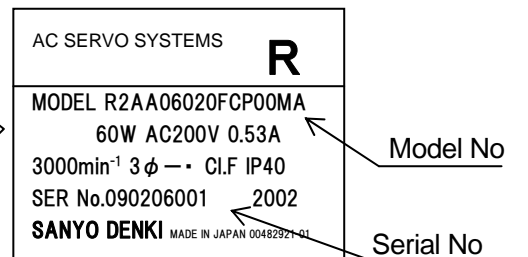

Servo amplifier

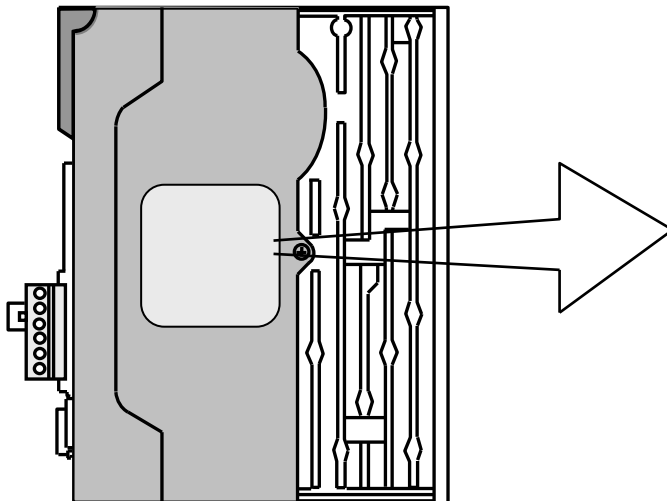

Servo amplifier main nameplate

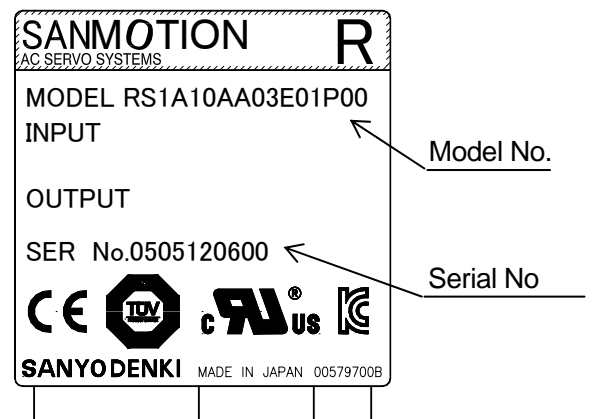

Interpretation of the serial number

Month (2 digits) + Year (2 digits) + Day (2 digits) + Serial number (4 digits) + Revision ("A" is abbreviated)

1. Prior to Use

[Servo amplifier model number]

■ Interpretation of servo motor model number

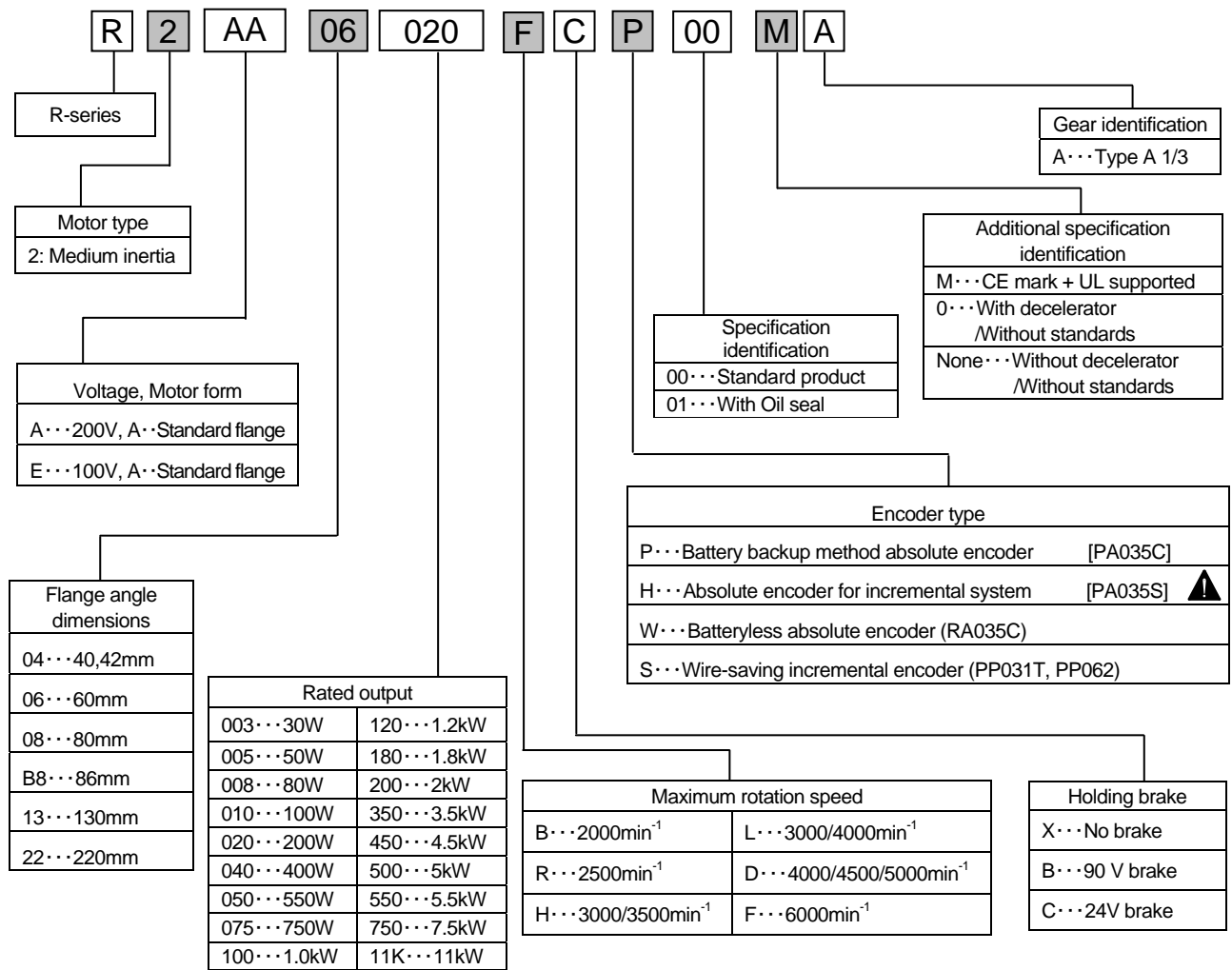

■ Encoder specifications

• Incremental Encoder

Model	Standard	Applicable range	Name
	Division number (Number of pulse)	Division number (Number of pulse)	
PP031T PP062	8000(2000P/R)	8192·20000·32768·40000 (2048·5000·8192·10000P/R)	Wire-saving incremental encoder

✓ Please contact our office about the combination with servo motor.

• Absolute Encoder

Type	Within 1 rotation	Multiple rotation	Notes
PA035C	131072 (17bit)	65536(16bit)	Battery backup method absolute encoder
PA035S	131072 (17bit)	-	Absolute encoder for incremental system 



To the customers using “Absolute encoder for incremental system”;
See the parameter set values for your servo amplifier in the table below and make sure to use them.

General parameter

Group	Page	Symbol	Name	Setting value	contents
C	00	ABS/INCSYS	Position detection system choice	00:_Absolute	Absolute system
C	08	ECLRFUNC	Absolute Encoder Clear Function Selection	01:_Status	Clear Only Encoder Status

1. Prior to Use

[Servo amplifier model number]

■ Interpretation of servo motor model number

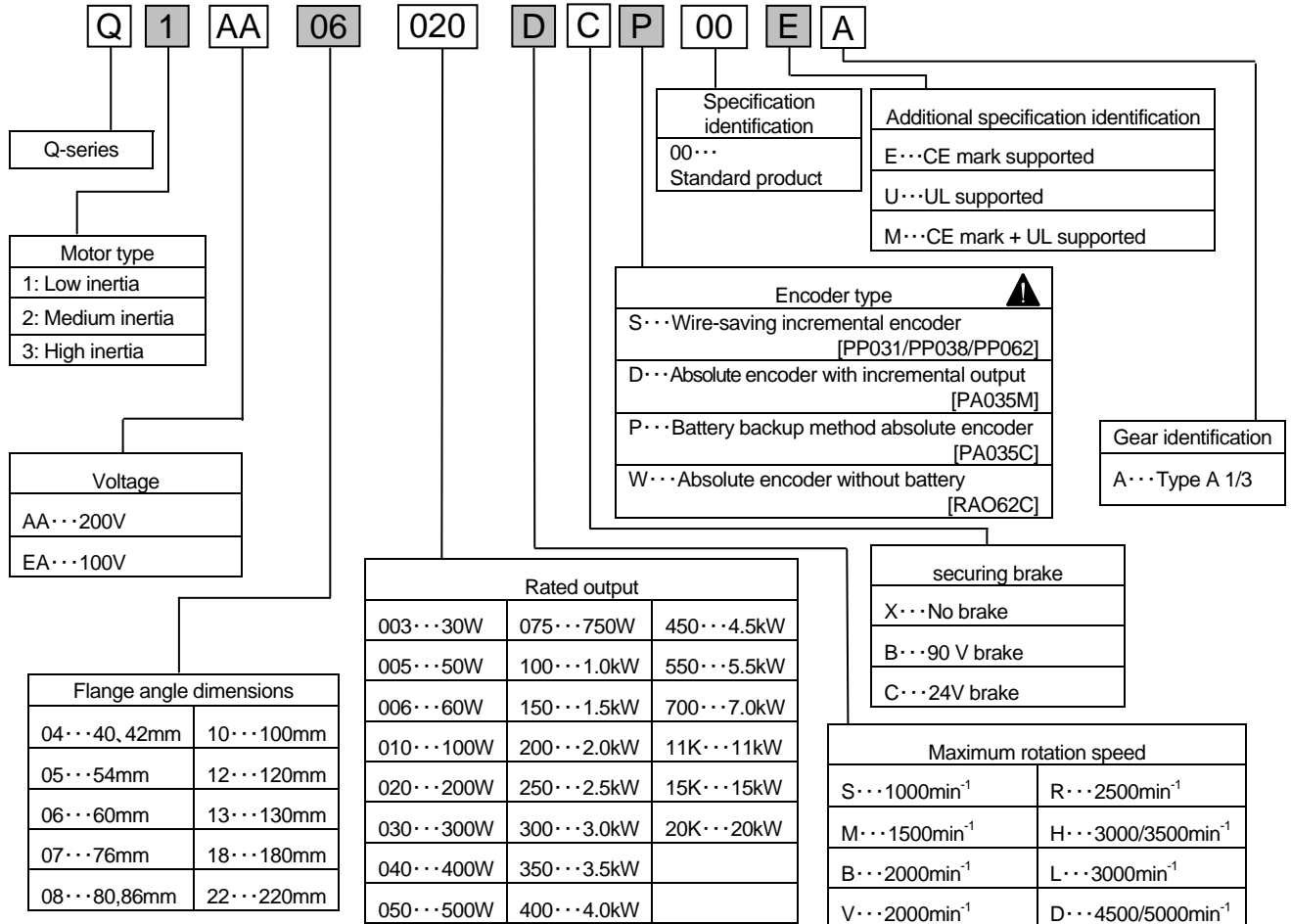

■ Encoder specifications

• Incremental encoder

Type	Resolution	Flange angle dimensions	Notes
PP031	8000/8192 P/R	40mm Min	Wire-saving incremental encoder
PP038	4096 to 25000 P/R	42mm Min	Wire-saving incremental encoder
PP062	8000/8192/20000/32768/40000 P/R	72mm Min	Wire-saving incremental encoder

• Absolute encoder

Type	Within 1 rotation	Multiple rotation	Notes
PA035C	131072 (17bit)	65536 (16bit)	Battery backup method absolute encoder
PA035M	8192 (13bit)	-	Absolute encoder with incremental output ⚠
RA062C	131072 (17bit)	8192 (13bit)	Absolute encoder without battery

To the customers using "Battery backup method absolute encoder" with incremental system;

See the parameter set values for your servo amplifier in the table below and make sure to use them.

General parameter

Group	Page	Symbol	Name	Setting value	Contents
C	00	ABS/INCSYS	Position detection system choice	01:_Incremental	Absolute system
C	08	ECLRFUNC	Absolute Encoder Clear Function Selection	01:_Status	Clear Only Encoder Status

1. Prior to Use

[Servo amplifier model number]

■ Interpretation of servo amplifier model number (Full number)

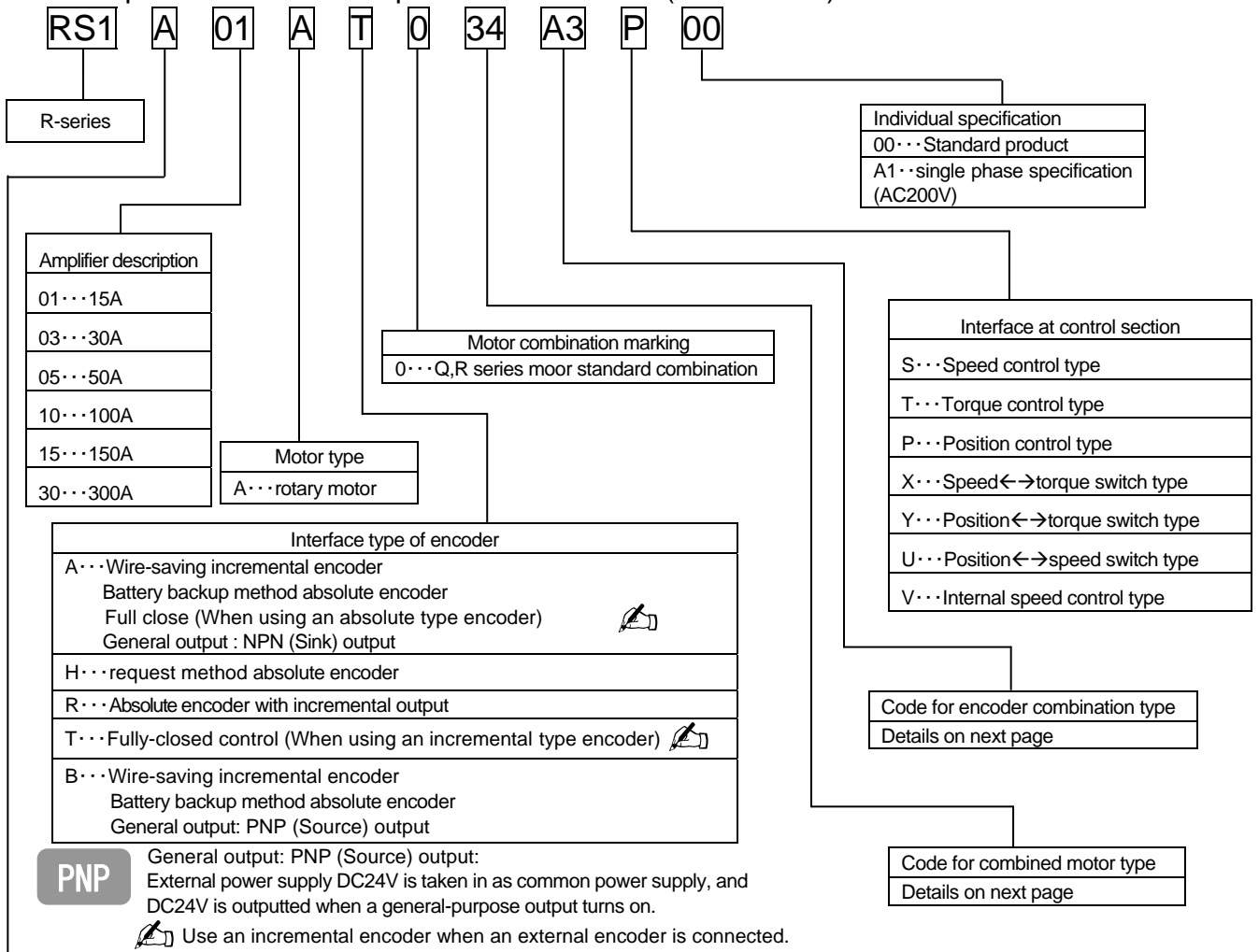

Power input, power part details			Model numbers by amplifier capacity		
Input voltage	Regenerative resistor	DB	15A...RS1□01 30A...RS1□03	50A...RS1□05 100A...RS1□10 150A...RS1□15	300A...RS1□30
AC200V	Built-in	W	L	A	-
		W/O	M	B	-
	-	W	A	L	A
AC100V	Built-in	W/O	B	M	B
		W	N	-	-
	-	W/O	P	-	-
	W	E	-	-	
-	W/O	F	-	-	

The design order is noted by alphabetical characters at the end of the Lot Number on the name plate.

NPN (sink) output and PNP (source) output
 NPN (sink) output and PNP (source)-output are the names of the general-purpose output circuit system of servo amplifier. PNP (source)-output servo amplifier was added in August, 2008 and later in addition to the previous NPN (sink)-output servo amplifier..

Please refer to the right figure.

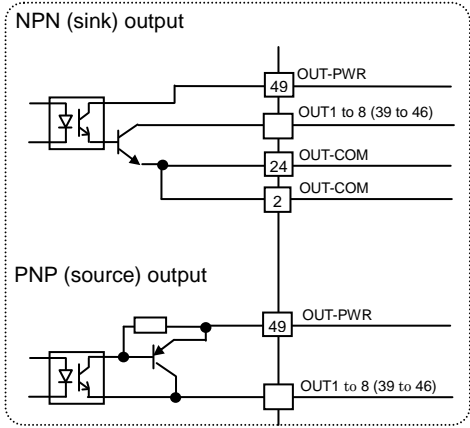

1. Prior to Use

[Servo amplifier model number]

■ Interpretation of servo amplifier model number (Abbreviated number)

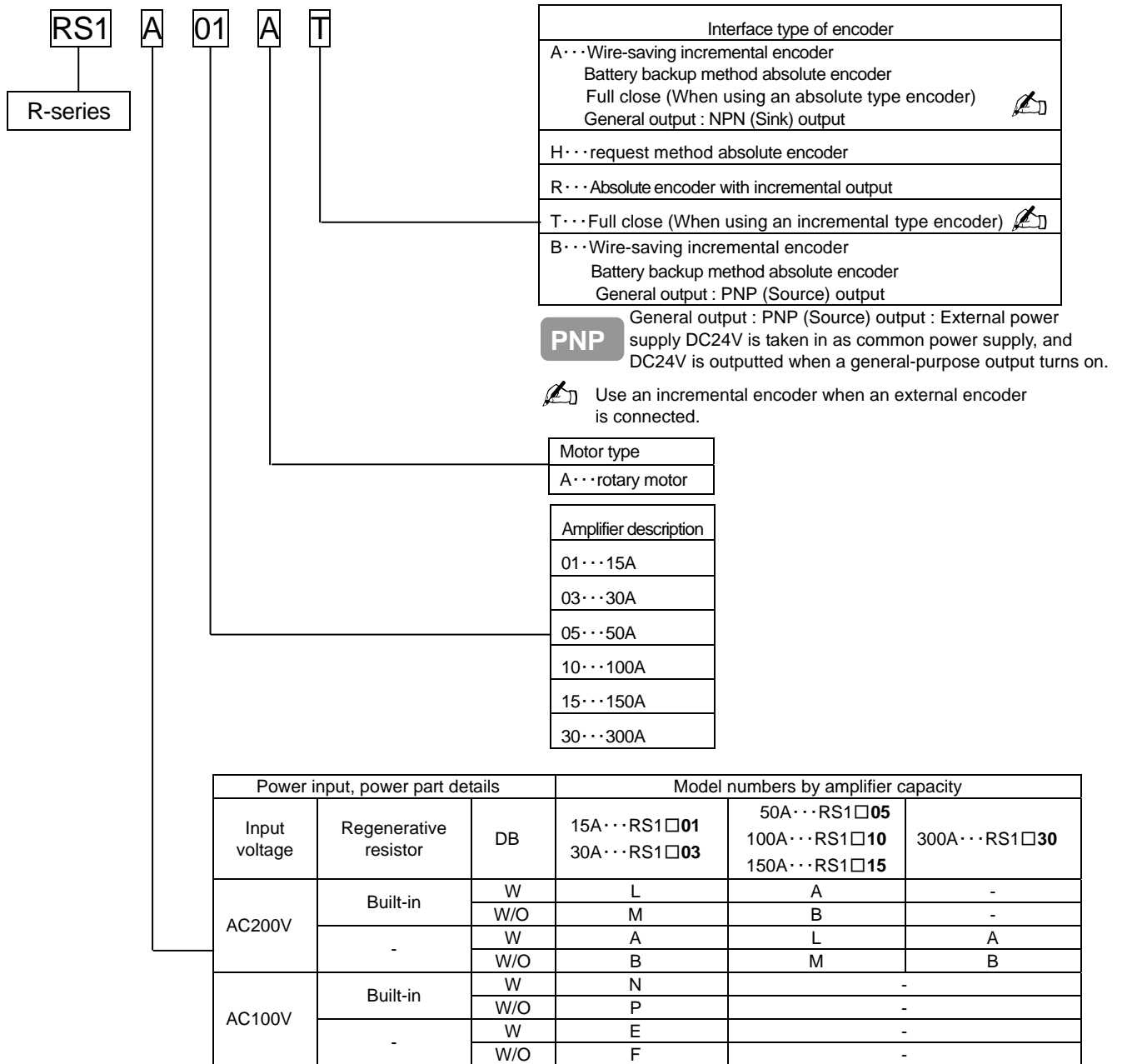

Refer to Chapters 5 and 6 for how to set parameters which have been set at the time of shipment, and to page 55 of the attached data for setting contents.

The design order is noted by alphabetical characters at the end of the Lot Number on the name plate.

1. Prior to Use

[Servo amplifier model number]

Motor setting and encoder type of abbreviated model numbers

Servo amplifier model number	Servo motor model number	Encoder	
RS1△01AA	P50B03003D	Wire-saving incremental encoder 2000P/R	
RS1△03AA	P50B07040D		
RS1△05AA	P50B08075D		
RS1△10AA	P60B13200H		
RS1△15AA	P80B22350H		
RS1△30AA	P60B18750R		
RS1△01AB	P50B03003D		General output: PNP (Source) output : External power supply DC24V is taken in as common power supply, and DC24V is outputted when a general-purpose output turns on.
RS1△03AB	P50B07040D		
RS1△05AB	P50B08075D		
RS1△10AB	P60B13200H		
RS1△15AB	P80B22350H		
RS1△30AB	P60B18750R		
RS1△01AH	P50B03003D	Request method absolute encoder 15bit	
RS1△03AH	P50B07040D		
RS1△05AH	P50B08075D		
RS1△10AH	P60B13200H		
RS1△15AH	P80B22350H		
RS1△30AH	P60B18750R		
RS1△01AR	P50B03003D	Absolute encoder with incremental output 2048P/R	
RS1△03AR	P50B07040D		
RS1△05AR	P50B08075D		
RS1△10AR	P60B13200H		
RS1△15AR	P80B22350H		
RS1△30AR	P60B18750R		
RS1△01AT	P50B03003D	Wire-saving incremental encoder 2000P/R	
RS1△03AT	P50B07040D		
RS1△05AT	P50B08075D		
RS1△10AT	P60B13200H		
RS1△15AT	P80B22350H		
RS1△30AT	P60B18750R		

△: Depends on input power voltage, regeneration resistance and dynamic brake resistance.

In case of 200VAC input voltage, A, B, L and M will be filled in.

In case of 100VAC input voltage, E, F, N and P will be filled in. (However, there are only RS1△01, RS1△03.)

1. Prior to Use

[Servo amplifier part names]

■ RS1□01A□/ RS1□03A□

Parts inside the cover (same for all capacity amplifiers)

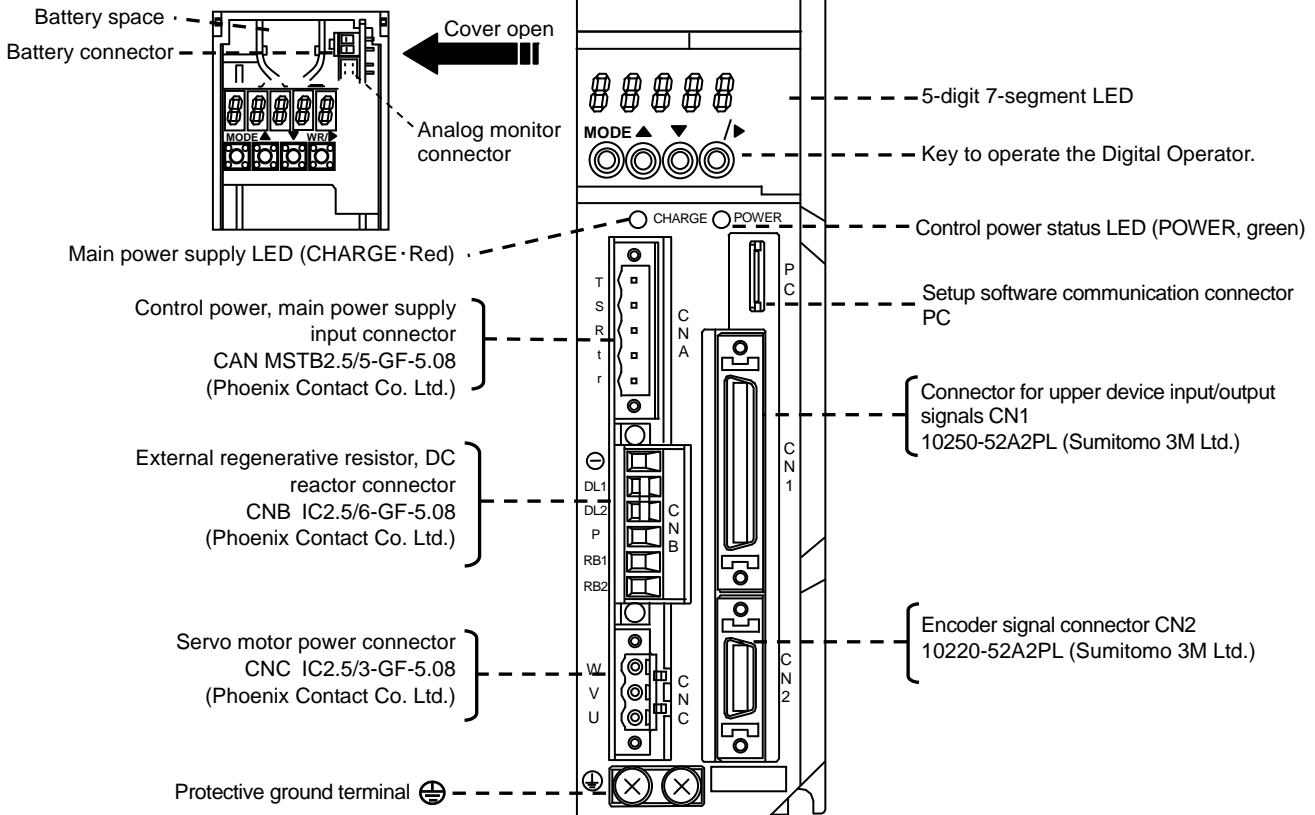

■ RS1□05A□

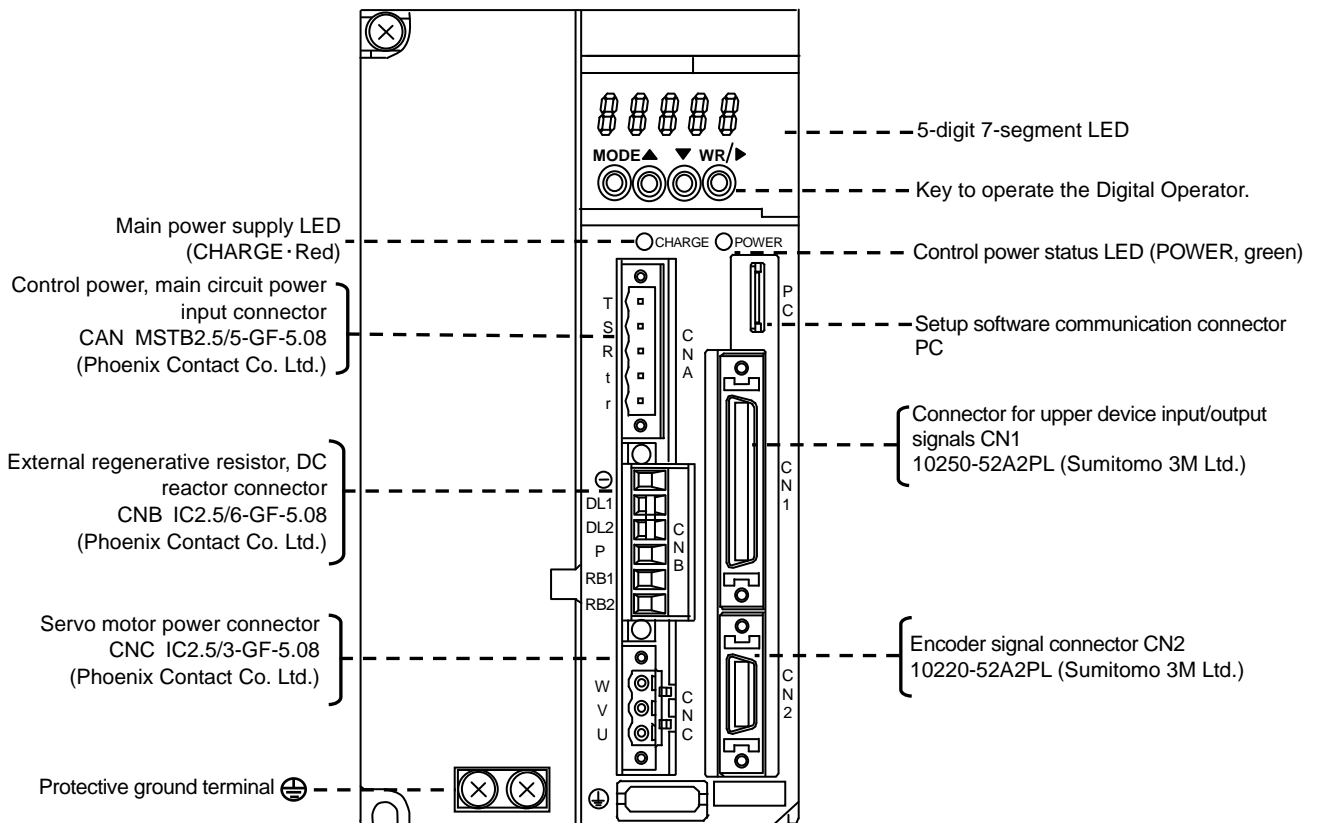

1. Prior to Use

[Servo amplifier part names]

■ RS1□10A□/ RS1□15A□

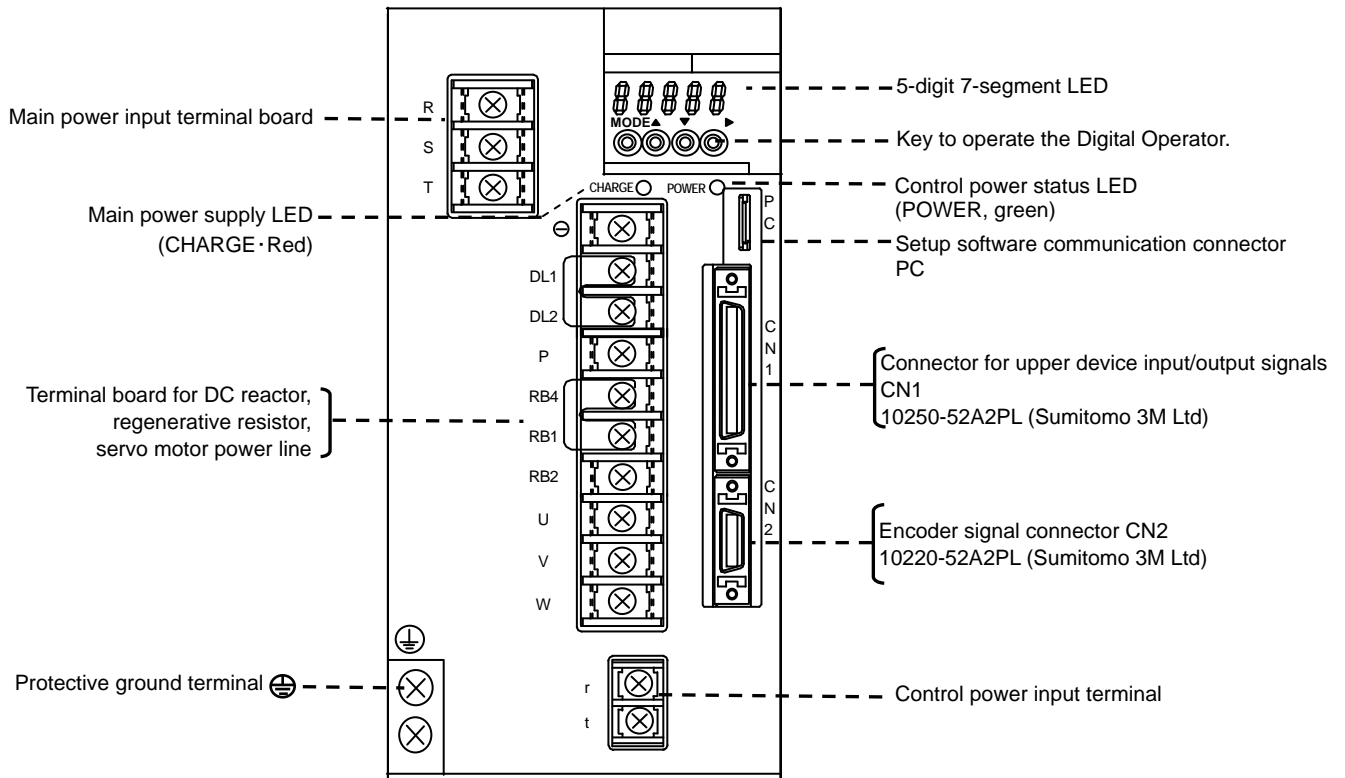

■ RS1□30A□

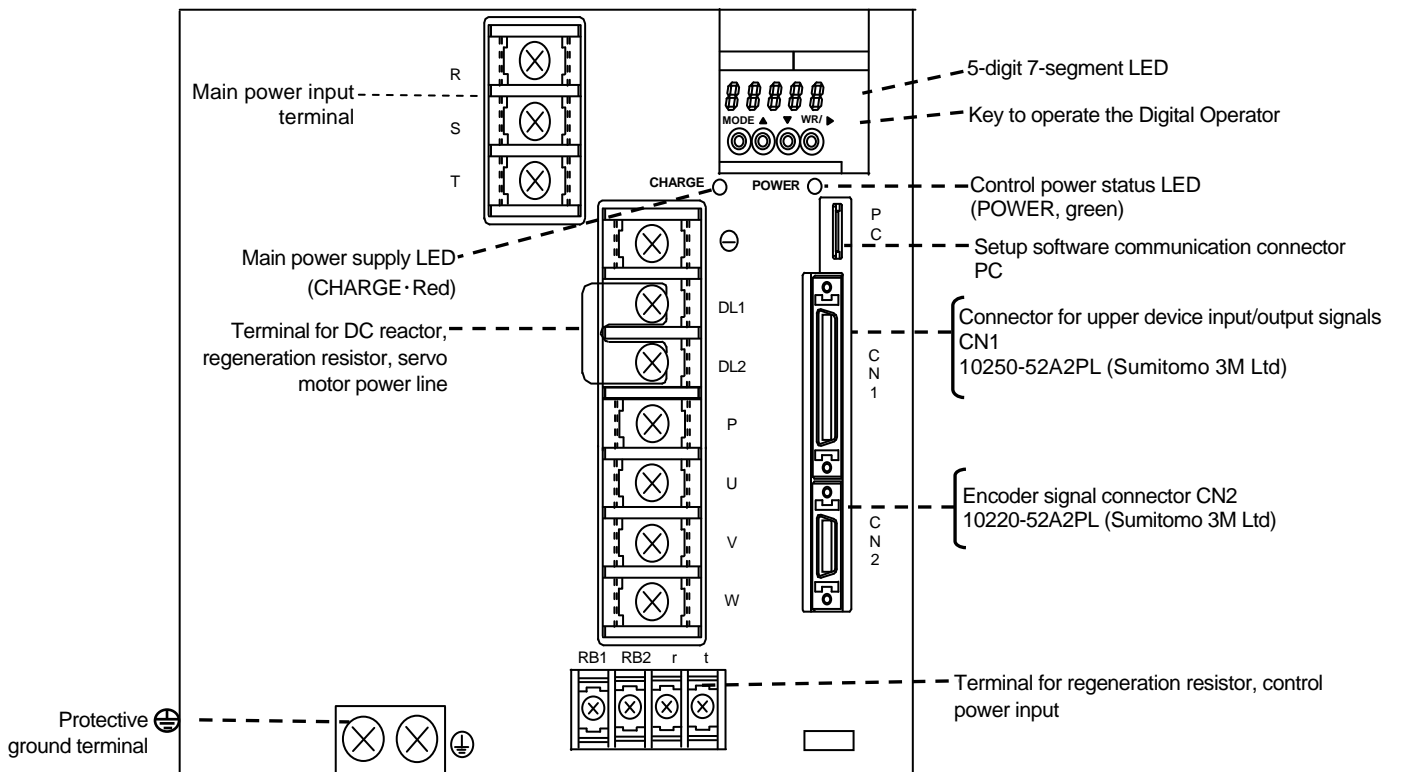

1. Prior to Use

[Servo motor part names]

■ Lead wire types

Q1□A04○○○△□◇
Q1□A06○○○△□◇
Q1AA07○○○△□◇
Q2□A04○○○△□◇
Q2□A05○○○△□◇
Q2□A07○○○△□◇
Q2AA08○○○△□◇
R2□A04○○○△□◇
R2□A06○○○△□◇
R2AA08○○○△□◇
R2AAB8○○○△□◇
R2AA10○○○△□◇

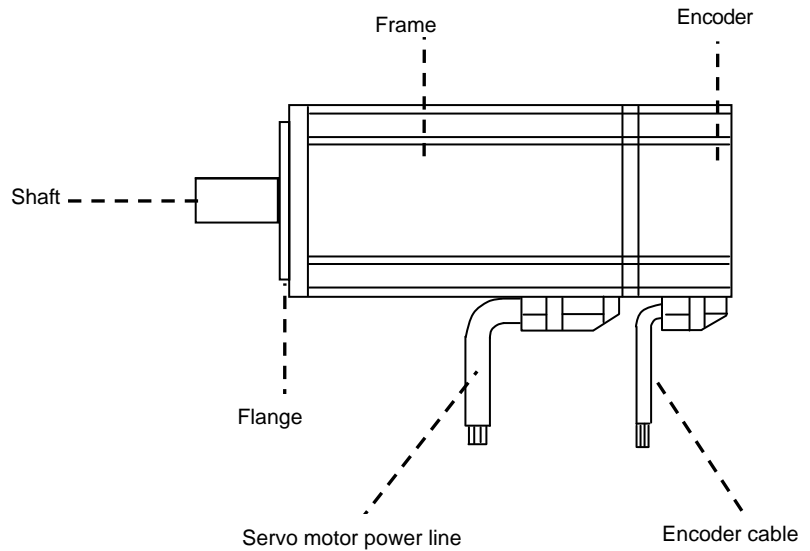

■ Cannon plug type

Q1AA10○○○△□◇
Q1AA12○○○△□◇
Q1AA13○○○△□◇
Q1AA18○○○△□◇
Q2AA10○○○△□◇
Q2AA13○○○△□◇
Q2AA18○○○△□◇
Q2AA22○○○△□◇
R2AA13○○○△□◇
R2AA22○○○△□◇
R2AA18○○○△□◇

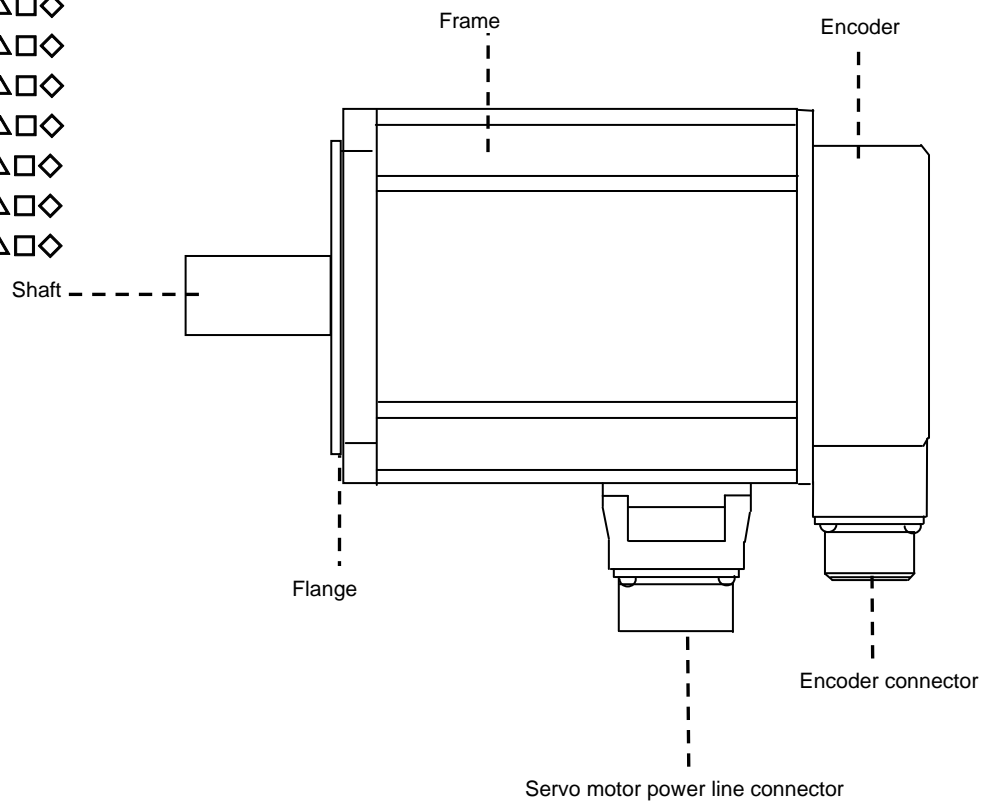

No Text on This Page.

[Installation]

◆	Servo amplifier	2-1
	■ Mounting direction and location	2-3
	■ Arrangement within the control box.....	2-3
◆	Servo motor.....	2-4
	■ Waterproofing and dust proofing.....	2-5
	■ Protective cover installation.....	2-5
	■ Gear installation.....	2-6
	■ Integration with the target machinery	2-6
	■ Allowable bearing load	2-8
	■ Cable installation considerations.....	2-9

2. Installation

[Servo amplifier]

- Please note the following points regarding the servo amplifier installation location and mounting method.

Various precautions



Installation on or near flammable materials can cause fire.	Do not place heavy objects or stand on it.
Operate the device within the specified environmental conditions.	Do not drop the device or subject it to excessive shock.
The device, which damaged or loading parts have damaged, should return for repair to the sales office.	Make sure no screws or other conductive or flammable materials get inside the servo amplifier.
Contact your distributor or sales office when storage of servo amplifier is an extended period of time (three years or more as a standard). The capacity of the electrolytic capacitor decreases by keeping a long term.	

If enclosed in a cabinet



The temperature inside the cabinet can exceed the external temperature depending on the power consumption of the device and the size of the cabinet. Consider the cabinet size, cooling, and placement, and make sure the temperature around the servo amplifier does not exceed 55°C. For longevity and reliability purposes it is recommended to keep the temperature below 40°C.

If there is a vibration source nearby



Protect the servo amplifier from vibration by installing it on a base with a shock absorber.

If there is a heat generator nearby



If the ambient temperature may increase due to convection or radiation, make sure the temperature near the servo amplifier does not exceed 55°C.

If corrosive gas is present



Long-term use may cause contact failure on the connectors and connecting parts.
Never use the device where it may be exposed to corrosive gas.

2.Installation

[Servo amplifier]

If explosive or combustible gas is present

Never use the device where explosive or combustible gas is present. The device's relays and contacts, regenerative resistors and other parts can arc (spark) and can cause fire or explosion.

If dust or oil mist is present

The device cannot be used where dust or oil mist is present. If dust or oil mist accumulates on the device, it can cause insulation deterioration or leakage between the conductive parts, and damage the servo amplifier.

If a large noise source is present

If inductive noise enters the input signals or the power circuit, it can cause a malfunction. If there is a possibility of noise, inspect the line wiring and take appropriate noise prevention measures. A noise filter should be installed to protect the servo amplifier.

2. Installation

[Servo amplifier]

■ Mounting direction and location

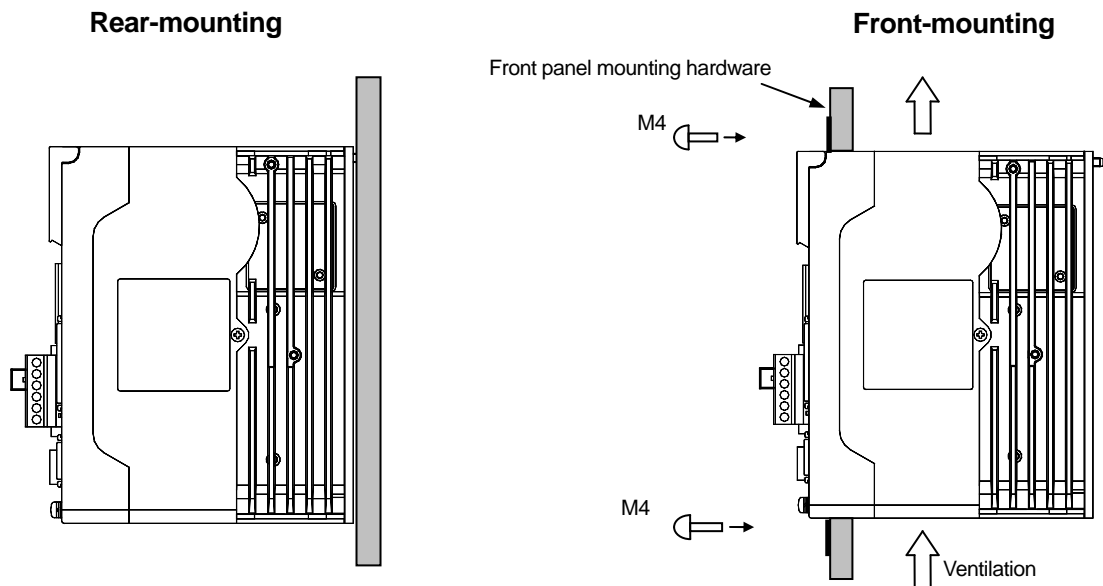

For metal fittings for front/rear mounting, refer to options (compatible with PY2 mounting).

■ Arrangement within the control machine

- Leave at least 50 mm space above and below the servo amplifier to ensure unobstructed airflow from the inside of the servo amplifier and the radiator. If heat gets trapped around the servo amplifier, use a cooling fan to create airflow.
- The ambient temperature of servo amplifier should always become 55°C or less. In addition, in order to secure a long-life and high reliability, we recommend you to use temperature below 40°C.
- Leave at least 10 mm space on both sides of the servo amplifier to ensure unobstructed airflow from the heat-sinks on the side and from the inside of the servo amplifier.
- If the R-series servo amplifier is installed on its side, make sure that the ambient temperature does not exceed 50°C, and mount the back panel to a metal plate.
RS1□01, RS1□03, RS1□05 : 2mm or more of recommendation metal plate thickness
RS1□10, RS1□15, RS1□30 : 5mm or more of recommendation metal plate thickness
- For RS1□03·RS1□05, a cooling fan is attached at the side. Therefore, it is recommended that the servo amplifier be mounted in an arrangement as shown below.

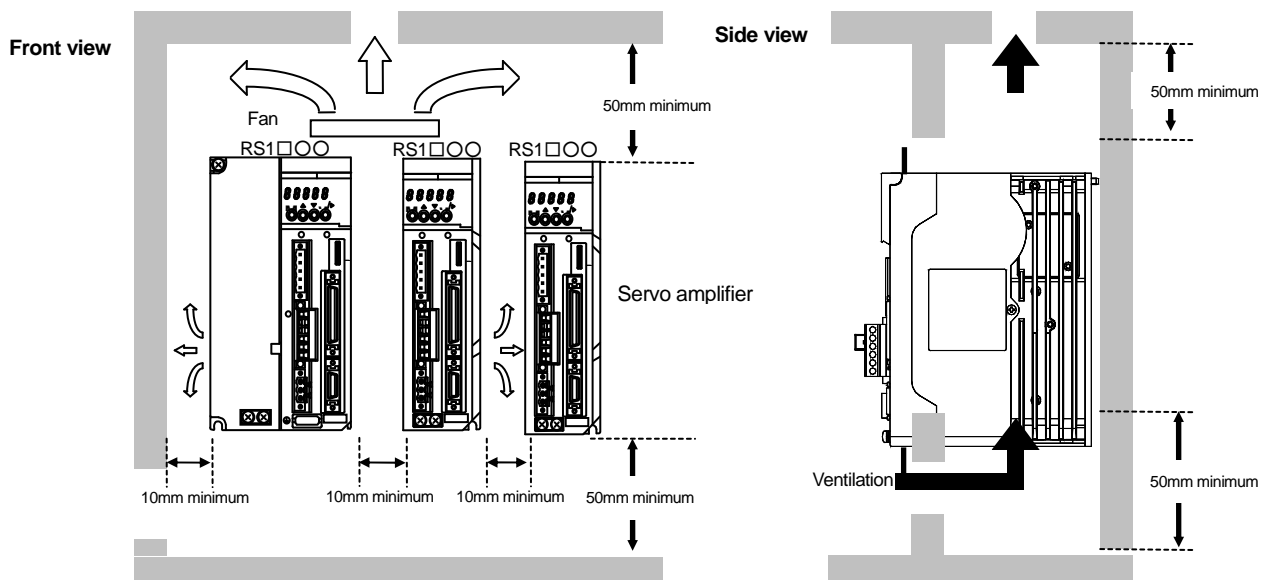

2. Installation

[Servo motor]

- Please note the following regarding the installation location and mounting method for the servo motor.

The servo motor is designed for indoor use. Make sure to install it indoors.	
Do not use the device in locations where the oil seal lip is continuously exposed to oil, or where the device is exposed to large quantities of water, oil drops, or cutting fluid. The motor is designed to withstand only small amounts of moisture spray.	
Ambient temperature: 0 to 40°C Storage temperature: -20 to 65°C Ambient humidity: 20 to 90%	Good ventilation, no corrosive or explosive gases present. No dust or dirt accumulation in the environment. Easy access for inspection and cleaning.

■ Mounting method

- Mounting in several orientations - horizontal, or with the shaft on top or bottom- is acceptable.
- If the output shaft is used in reduction devices that use grease, oil, or other lubricants, or in mechanisms exposed to liquids, the motor should be installed in a perfectly horizontal or downward position. In some models, there is an oil-seal attached to the output shaft. If the shaft is facing upwards and the seal lip is continuously exposed to oil, oil can enter inside the motor and cause damage, as a result of wear and degradation of the oil seal. In such cases an oil-seal should be used on the load-side as well. Contact your distributor or sales office if the device is to be used in such conditions.
- The motor connector and cable outlet should be installed facing downwards, as nearly vertical as possible.
- In vertical installation, create a cable trap to prevent oily water from getting into the motor.

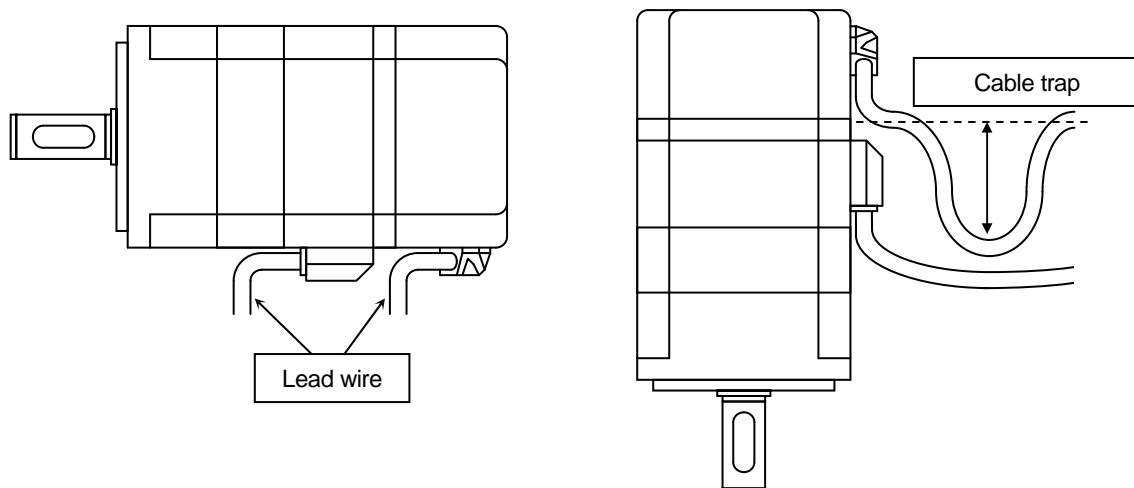

Waterproofing and dust proofing

- The protection inside the motor conforms to IEC standards (IEC34-5). However, such protection is suitable only for short-term use. For regular use, additional sealing measures are required. Be sure to handle the connector carefully, as damage to the exterior of the connector (painted surface) can reduce its waterproofing capability.
- The motor waterproofing is of IPX 7 class level, but still requires careful handling. If the motor is continuously wet, due to the respiratory effect of the motor, liquid may penetrate inside the motor.
- Install a protective cover to prevent corrosion of the coating and the sealing material, which can be caused by certain types of coolants (especially water soluble types).
- Q1- and Q2-series motors with the canon plugs are only IP67 rated if waterproof connectors and/or conduits are used on the matching canon connectors.
- Q1-series motors (with all flange sizes) and Q2-series motors (with the 42mm flange size) not of the canon plug type are IP40 rated, but IP67 rated waterproofing is also available as an option. Q2-series motors with flange sizes of 54mm, 76mm and 86mm have IP67 rated waterproofing. R2-series motors have IP67 rated waterproofing, except for shaft passages and cable ends.

Protective cover installation

- Install a protective cover (as described below) for motors continuously subjected to liquids.
- Turn the connectors (lead outlets) downwards within the angle range shown in the picture below.
- Install the cover on the side where the water or oil would drip.
- Install the cover at an angle (for runoff), to prevent water or oil from collecting.
- Make sure that the cable does not get soaked in water or oil.
- Create a sag in the cable outside the cover, to make sure water or oil does not penetrate to the motor.
- If it is not possible to install the connectors (lead outlets) facing downwards, create a sag in the cable to prevent water or oil from entering the motor.

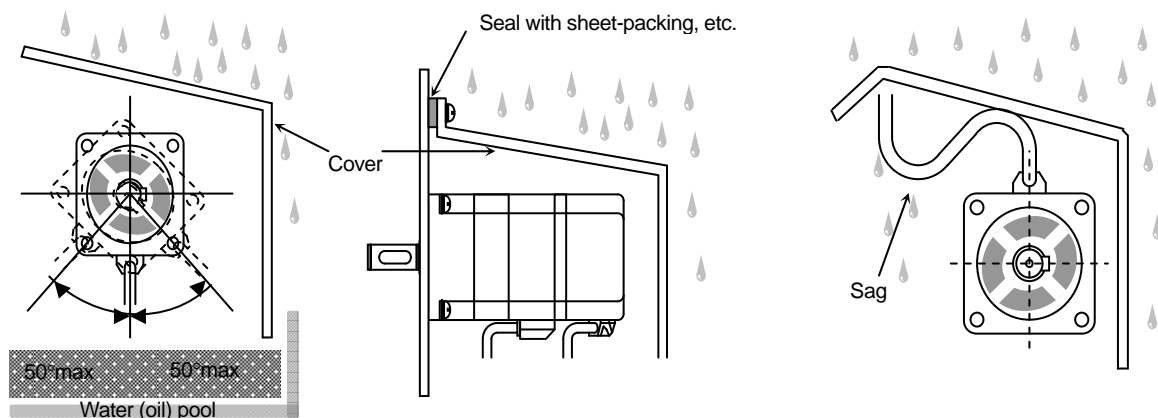

2. Installation

[Servo motor]

■ Gear installation

- The oil level of the gear box should be below the oil seal lip, for a slight spraying effect on the lip.
- Create a hole to prevent pressure build-up inside the gear box, as pressure can cause water or oil to penetrate the oil seal and enter inside the motor.
- If the motor is used with the shaft facing upwards, an oil seal should be used on the opposite side of the mechanism as well. In addition, install a drain to expel the water or oil that may penetrate through this oil seal.

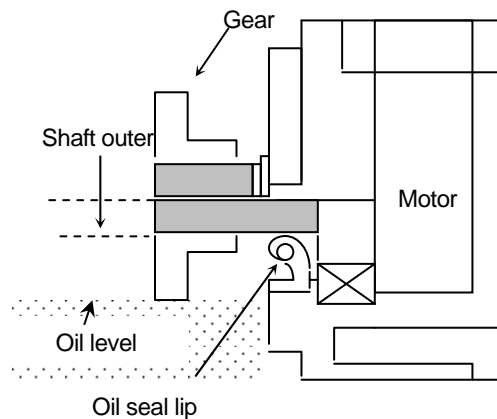

■ Integration with the target machinery

- Refer to the drawing below for correct centering of the motor shaft and the target machinery. Please note when using a rigid coupling that even a slight mistake in centering can damage the output shaft.

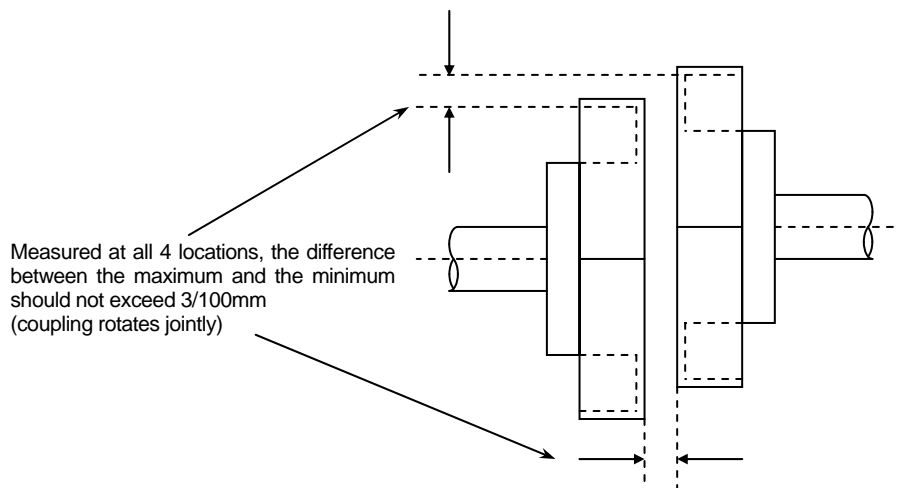

2. Installation

[Servo motor]

- Do not subject the motor shaft to shock, as the precision encoder is directly connected to it. If it is absolutely necessary to hit the motor for position adjustment or other reasons, use a rubber or plastic hammer and hit the front flange area.

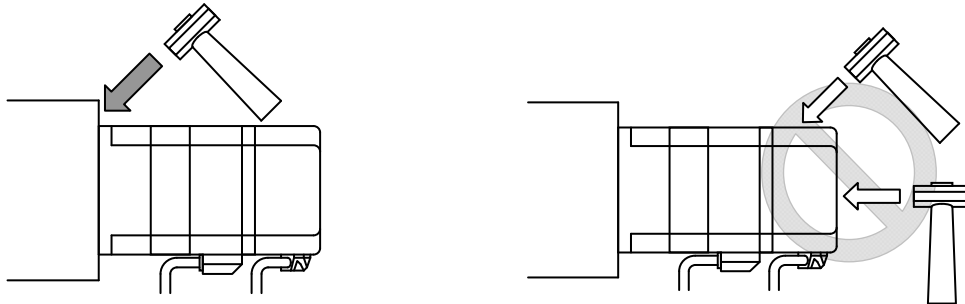

- If mounting to a machine, create enough mounting holes for smooth coupling of the motor flange rabbet. The mounting surface should be flat, otherwise damage to the shaft or the load may occur.
- Use the screw at the end of the shaft for installing parts such as the gear, pulley, or coupling, to avoid shock.

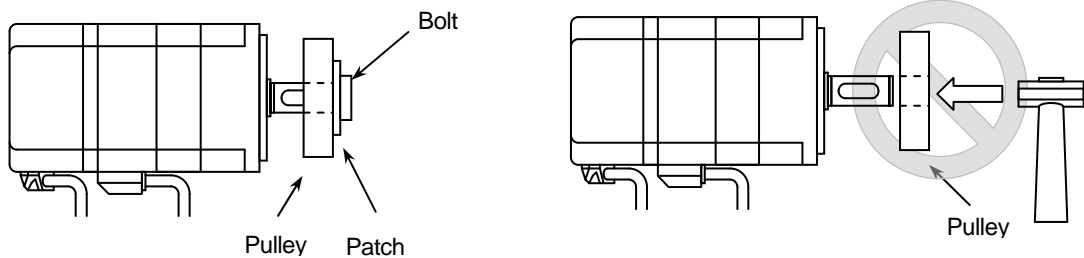

- Tapered motor shafts transmit the torque via the tapered surface. Make sure the key fits without rattling. The tapered surface contact should be no less than 70%.
- Use a special tool for removing the gear, pulley, etc.

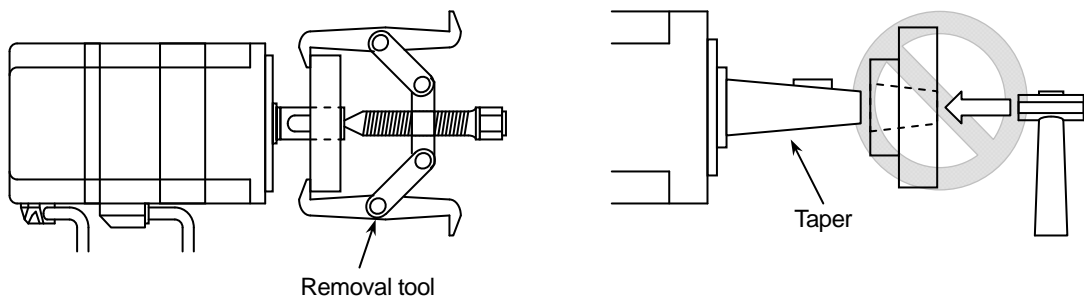

2. Installation

[Servo motor]

Allowable bearing load

- The table below shows the allowable bearing load of the servo motors. Do not apply excessive thrust load or radial load. In case of belt driving, make sure that the shaft converted value of belt tension does not exceed the allowable values shown below. The thrust load and radial load tolerance values assume individual application to the shaft.

The radial load tolerance value is the maximum load that can be applied at the point measured 1/3 of the distance from the tip of the output shaft.

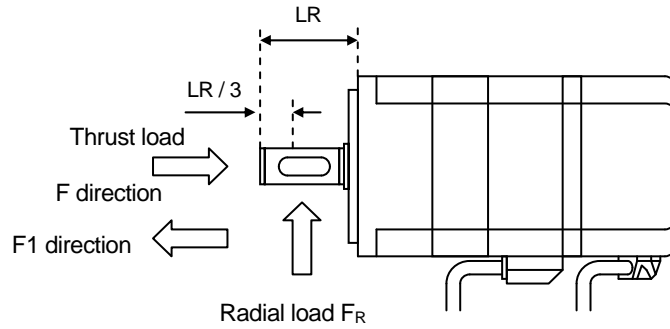

	Model	Assembly			Operation				
		Radial load (N)s		Thrust load (N)		Radial load (N)		Thrust load (N)	
		F_R	F direction	F1 direction	F_R	F direction	F1 direction		
Q1	Q1□A04003	98	78	78	49	29	29		
	Q1□A04005	150	98	98	98	29	29		
	Q1□A04010	150	98	98	98	29	29		
	Q1□A06020	390	200	200	200	78	78		
	Q1AA06040	390	200	200	250	98	98		
	Q1AA07075	590	390	390	340	200	200		
	Q1AA10100	980	290	290	690	200	200		
	Q1AA10150	980	290	290	690	200	200		
	Q1AA10200	980	290	290	690	200	200		
	Q1AA10250	980	290	290	690	200	200		
	Q1AA12100	980	290	290	690	290	290		
	Q1AA12200	980	290	290	690	290	290		
	Q1AA12300	980	290	290	690	290	290		
	Q1AA13300	2000	390	390	980	390	390		
Q1AA13400	2000	390	390	1200	390	390			
Q1AA13500	2000	390	390	1200	390	390			
Q1AA18450	2300	1900	1900	1500	490	490			
Q1AA18750	3900	2000	2000	1800	590	590			
Q2	Q2□A04006	150	98	98	98	29	29		
	Q2□A04010	150	98	98	98	29	29		
	Q2□A05005	200	200	150	150	78	78		
	Q2□A05010	200	200	150	150	78	78		
	Q2□A05020	250	200	150	200	78	78		
	Q2AA07020	250	490	200	200	98	98		
	Q2AA07030	250	490	200	200	98	98		
	Q2AA07040	250	490	200	250	98	98		
	Q2AA07050	250	490	200	250	98	98		
	Q2AA08050	590	780	290	340	200	200		
	Q2AA08075	590	780	290	340	200	200		
	Q2AA08100	590	780	290	340	200	200		
	Q2AA10100	980	290	290	690	200	200		
	Q2AA10150	980	290	290	690	200	200		
	Q2AA13050	1700	1300	1300	490	290	290		
	Q2AA13100	1700	1300	1300	690	290	290		
	Q2AA13150	1700	1300	1300	690	290	290		
Q2AA13200	1700	1300	1300	690	290	290			
Q2AA18200	2300	1900	1900	1500	490	490			

2.Installation

[Servo motor]

	Model	Assembly			Operation		
		Radial load (N)s	Thrust load (N)		Radial load (N)	Thrust load (N)	
		F _R	F direction	F1 direction	F _R	F direction	F1 direction
Q2	Q2AA22550	3900	2000	2000	1800	590	590
	Q2AA22700	3900	2000	2000	2500	1100	1100
	Q2AA2211K	3900	2000	2000	2700	1500	1500
	Q2AA2215K	3900	2000	2000	2300	1500	1500
R2	R2□A04003	98	78	78	49	29	29
	R2□A04005	150	98	98	98	29	29
	R2EA04008	150	98	98	98	29	29
	R2AA04010	150	98	98	98	29	29
	R2□A06010	150	98	98	98	29	29
	R2□A06020	390	200	200	200	68	68
	R2AA08020	390	200	200	200	98	98
	R2AA06040	390	200	200	250	68	68
	R2AA08040	390	200	200	250	98	98
	R2AA08075	590	390	390	340	200	200
	R2AAB8075	590	780	290	340	200	200
	R2AAB8100	590	780	290	340	200	200
	R2AA13050	980	1400	1400	640	490	490
	R2AA13120	1700	1900	1900	640	490	490
	R2AA13200	1700	1900	1900	640	490	490
R2AA22500	2300	1900	1900	1500	490	490	

■ Cable installation considerations

- Make sure that no stress is applied to the cable and that it is undamaged.
- If the servo motor is installed in a moving location, make sure that no excessive stress is applied to the cable, by allowing a large bending radius.
- Avoid pulling the cable over sharp objects such as cutting scrap that can damage its exterior. Make sure the cable is not touching any machinery, and that it is out of the path of people and machines.
- Prevent bending or additional weight stress on the cable connection by clamping the cable to the machinery. In applications where the motor or the cable is moving using a cable bear, the bending radius should be based on the required cable-life and the type of cable used.
- Install the cables of moving parts in a manner that permits easy regular replacement. Consult with your distributor or sales office for recommendations, if you use cables for moving parts.

[Wiring]

◆	Packaged Wiring Diagram	3-1
◆	High Voltage Circuit/Name ▪ Function ▪ Terminal Number ····	3-5
◆	Tightening Torque of High Voltage Circuit Terminal ·····	3-6
◆	Wiring Example of High Voltage Circuit ▪ Protective Circuit	3-7
◆	Description of CN Terminal/Low Voltage Circuit ·····	3-11
◆	Description of CN1 Terminal/Low Voltage Circuit ·····	3-12
◆	Overall Wiring Diagram of CN1/Low Voltage Circuit ·····	3-13
◆	Wiring Example of CN1 Input Circuit/Low Voltage Circuit.....	3-15
◆	Wiring Example of CN1 Output Circuit/Low Voltage Circuit ···	3-18
◆	Wiring of CN2/Low Voltage Circuit.....	3-21
◆	Power Source ▪ Peripherals.....	3-26
◆	Cable Diameter	3-28
◆	How to Process CN1/CN2 Shield	3-30

3.Wiring

[Packaged wiring diagram RS1□01/RS1□03/RS1□05]

■ Packaged wiring diagram

Do not connect S-phase terminal in the usage of AC200V single phase input.

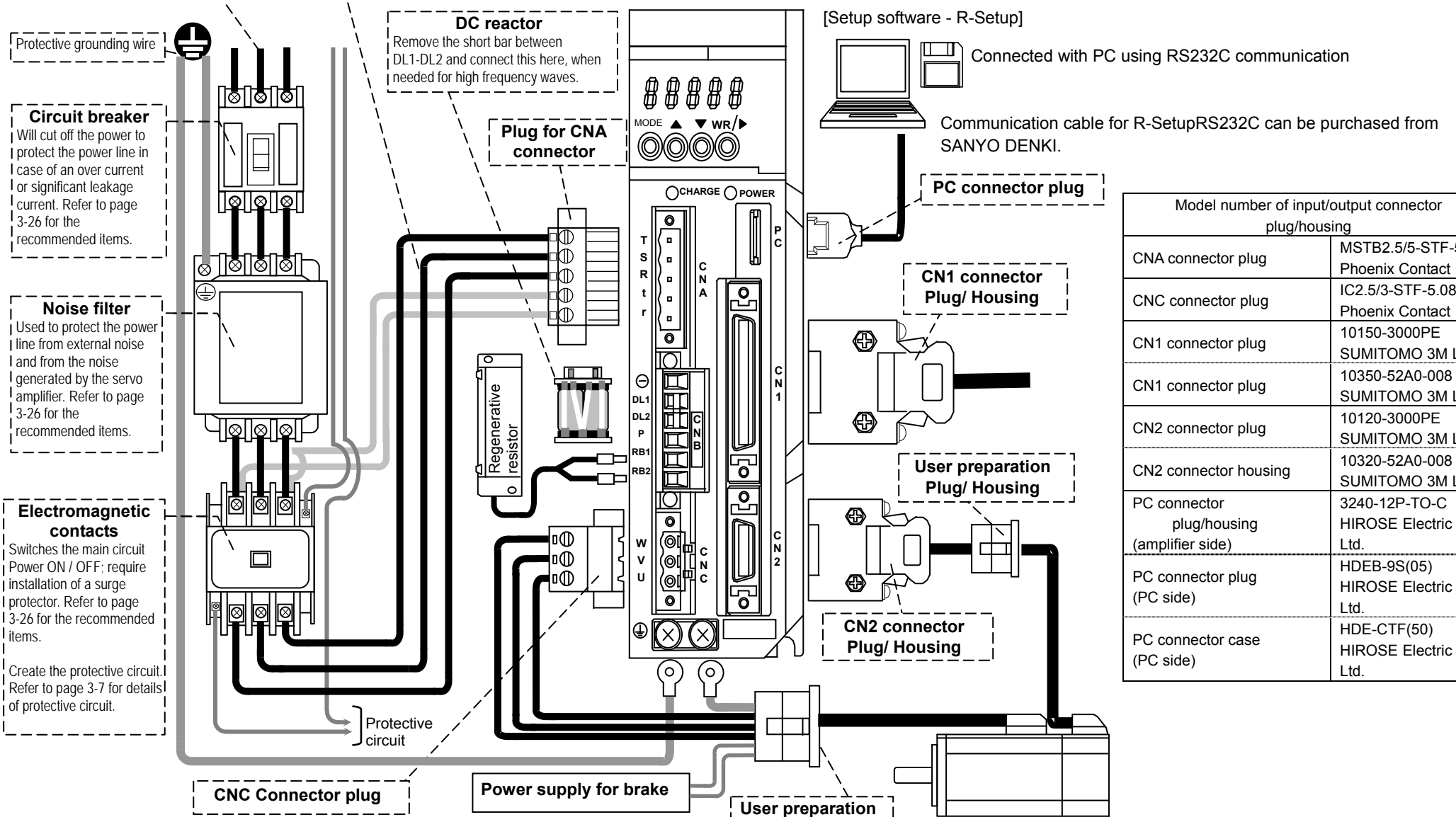

Model number of input/output connector plug/housing	
CNA connector plug	MSTB2.5/5-STF-5.08 Phoenix Contact
CNC connector plug	IC2.5/3-STF-5.08 Phoenix Contact
CN1 connector plug	10150-3000PE SUMITOMO 3M Ltd.
CN1 connector plug	10350-52A0-008 SUMITOMO 3M Ltd.
CN2 connector plug	10120-3000PE SUMITOMO 3M Ltd.
CN2 connector housing	10320-52A0-008 SUMITOMO 3M Ltd.
PC connector plug/housing (amplifier side)	3240-12P-T0-C HIROSE Electric Co., Ltd.
PC connector plug (PC side)	HDEB-9S(05) HIROSE Electric Co., Ltd.
PC connector case (PC side)	HDE-CTF(50) HIROSE Electric Co., Ltd.

3. Wiring

[Packaged wiring diagram RS1□01/RS1□03]

■ Packaged wiring diagram AC100V input type RS1□01A / RS1□03A

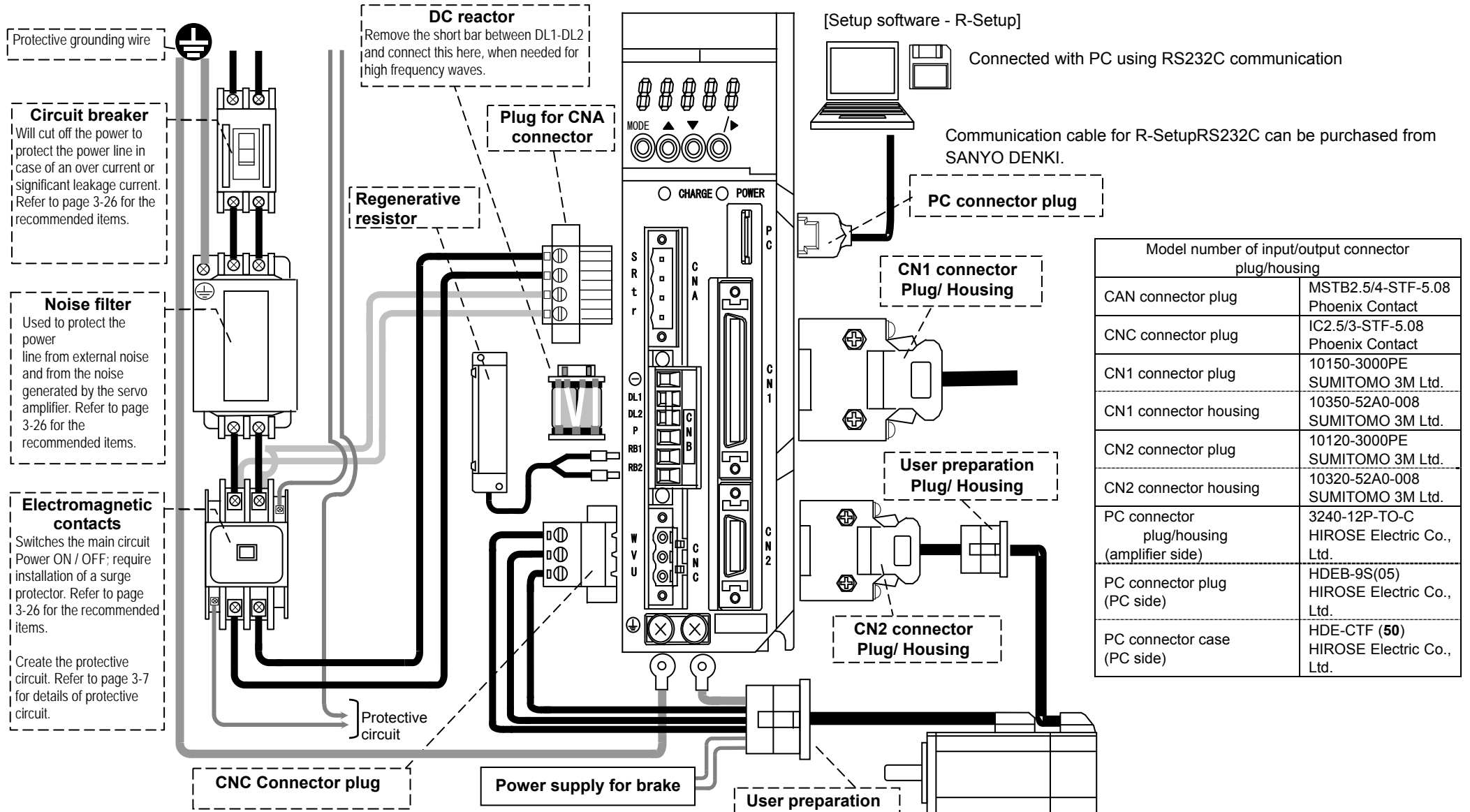

3. Wiring

[Packaged wiring diagram RS1□10/RS1□15]

■ Packaged wiring diagram

AC200V input type RS1□10A / RS1□15A

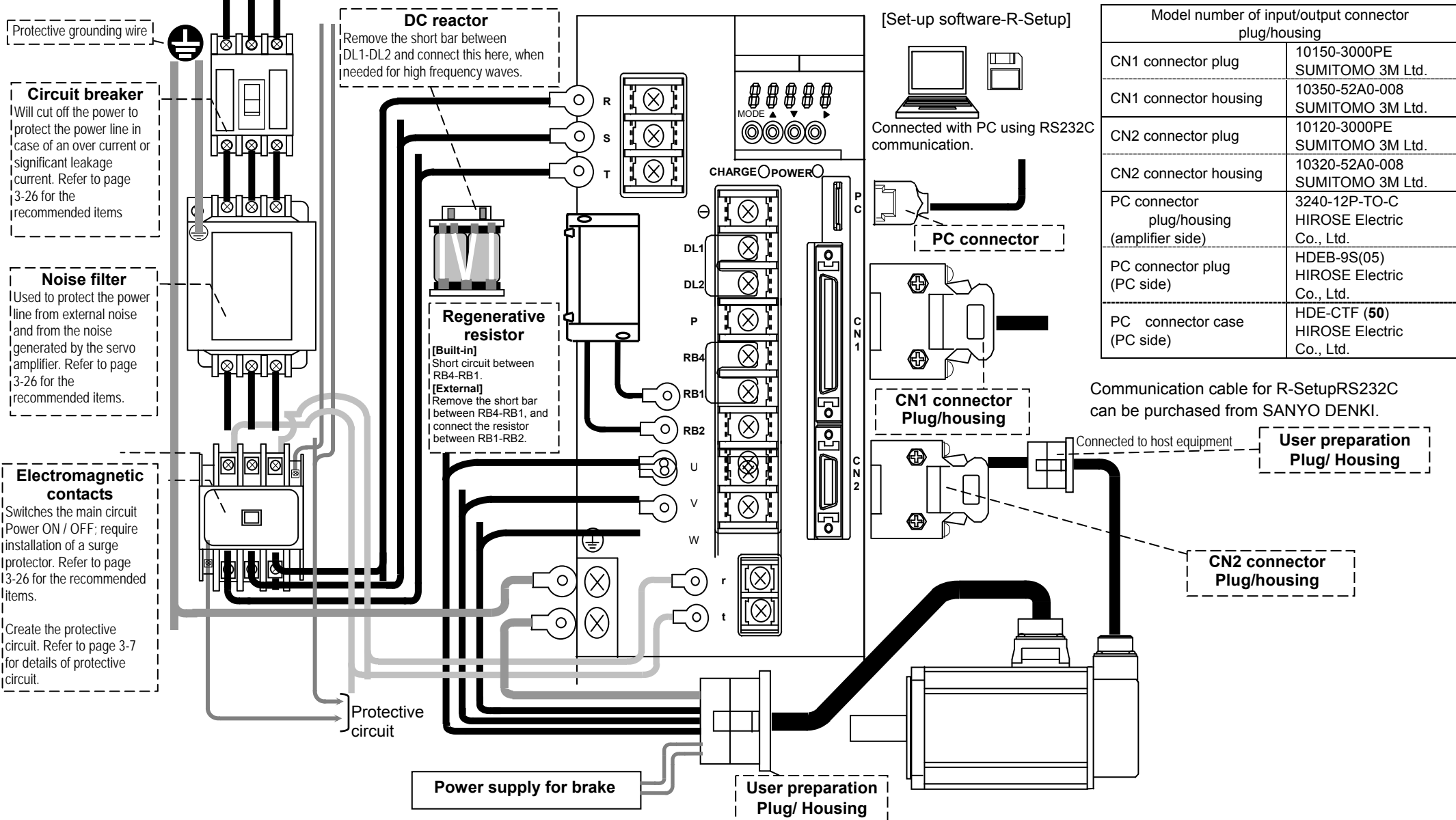

Protective grounding wire

Circuit breaker
Will cut off the power to protect the power line in case of an over current or significant leakage current. Refer to page 3-26 for the recommended items

Noise filter
Used to protect the power line from external noise and from the noise generated by the servo amplifier. Refer to page 3-26 for the recommended items.

Electromagnetic contacts
Switches the main circuit Power ON / OFF; require installation of a surge protector. Refer to page 3-26 for the recommended items.
Create the protective circuit. Refer to page 3-7 for details of protective circuit.

DC reactor
Remove the short bar between DL1-DL2 and connect this here, when needed for high frequency waves.

Regenerative resistor
[Built-in] Short circuit between RB4-RB1.
[External] Remove the short bar between RB4-RB1, and connect the resistor between RB1-RB2.

[Set-up software-R-Setup]
Connected with PC using RS232C communication.

Model number of input/output connector plug/housing	
CN1 connector plug	10150-3000PE SUMITOMO 3M Ltd.
CN1 connector housing	10350-52A0-008 SUMITOMO 3M Ltd.
CN2 connector plug	10120-3000PE SUMITOMO 3M Ltd.
CN2 connector housing	10320-52A0-008 SUMITOMO 3M Ltd.
PC connector plug/housing (amplifier side)	3240-12P-TO-C HIROSE Electric Co., Ltd.
PC connector plug (PC side)	HDEB-9S(05) HIROSE Electric Co., Ltd.
PC connector case (PC side)	HDE-CTF (50) HIROSE Electric Co., Ltd.

Communication cable for R-SetupRS232C can be purchased from SANYO DENKI.

Connected to host equipment
User preparation Plug/ Housing

CN2 connector Plug/housing

Power supply for brake

User preparation Plug/ Housing

3.Wiring

[Packaged wiring diagram RS1□30]

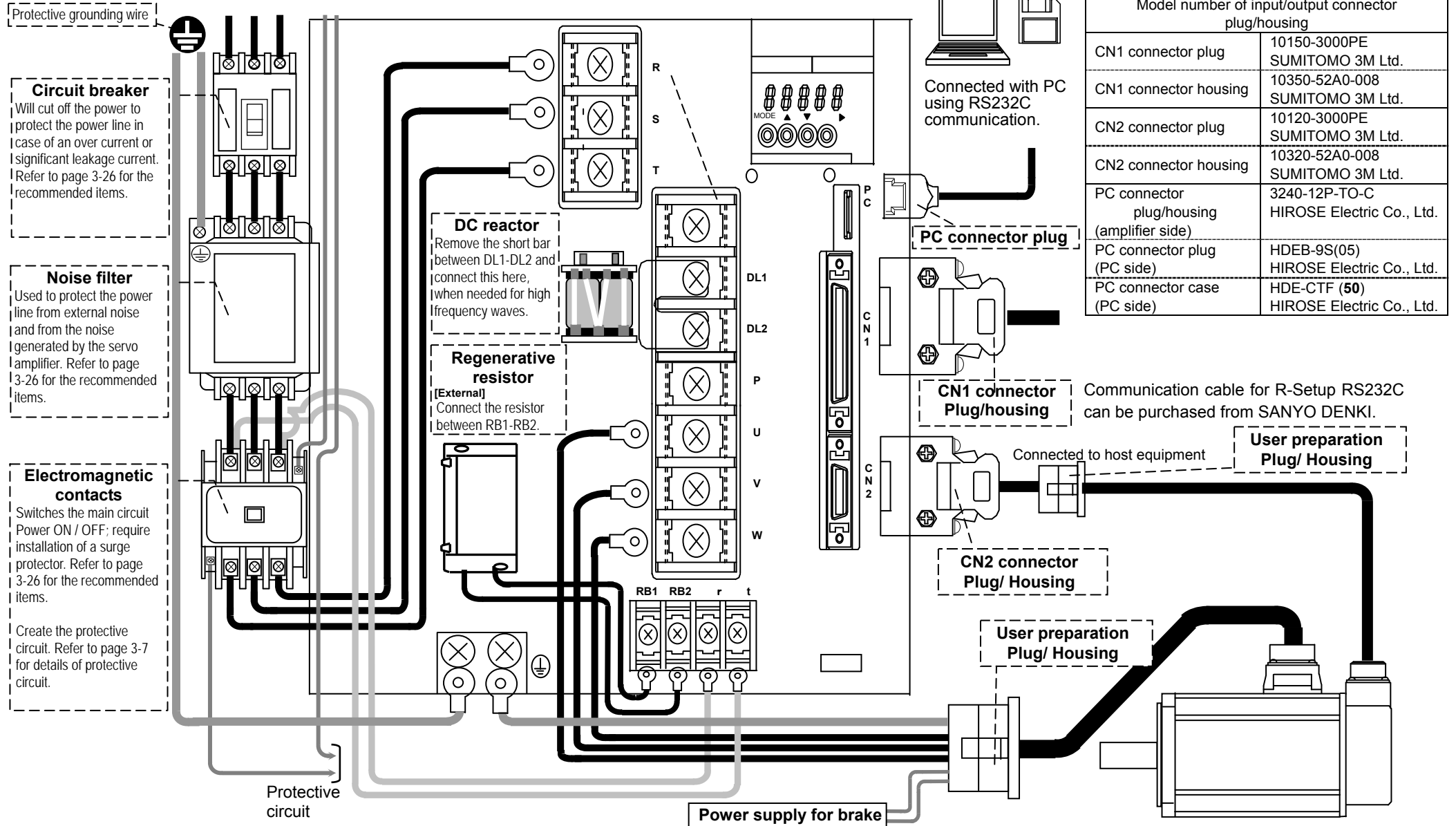

■ Packaged wiring diagram AC200V input type /RS1□30A

[Set-up software - R-Setup]



3. Wiring [High voltage circuit: Terminal names and functions]

■ High voltage circuit; terminal names and functions

Terminal name	Connector marking	Remarks
Main power source	R·T or R·S·T	Single phase AC100 to 115V + 10%, -15% 50/60Hz±3%
		Single phase AC200 to 230V + 10%, -15% 50/60Hz±3%
		Three phase AC200 to 230V + 10%, -15% 50/60Hz±3%
Control power source	r·t	Single phase AC100 to 115V + 10%, -15% 50/60Hz±3%
		Single phase AC200 to 230V + 10%, -15% 50/60Hz±3%
Servo motor connector	U·V·W	Connected with servo motor
Safeguard connector		Connected with grounding wire of power source and of servo motor.
Regeneration resistance connector	RB1·RB2 RB4	RS1□01 RS1□03 RS1□05 RS1□30 Regeneration resistance will be connected to RB1·RB2. If it is built-in, regeneration resistance has been connected at the time of shipment. In case of short regeneration power, an external regeneration resistance is connected to RB1·RB2. There is no terminal RB4.
		RS1□10 RS1□15 In case of a built-in regeneration resistance, RB1·RB4 are short circuited by a short bar at the time of shipment. If regeneration power is short, remove the short bar between RB1·RB4 (open) and connect an external regeneration resistance at RB1·RB2.
DC reactor connector	DL1·DL2	Short circuited at the time of shipment. If high frequency waves need to be controlled, remove the short bar between DL1·DL2 and connect a DC reactor between DL1·DL2.
Maker maintenance	P· 	For maker maintenance. Do not connect anything.

■ How to insert high voltage circuit connector

- Insert the wire into ferrule, and use a special tool to crimp it in.
- Insert the ferrule deep into the connector, and tighten it with a special minus screw driver or something.
The recommended torque is 0.5 to 0.6 N·m.

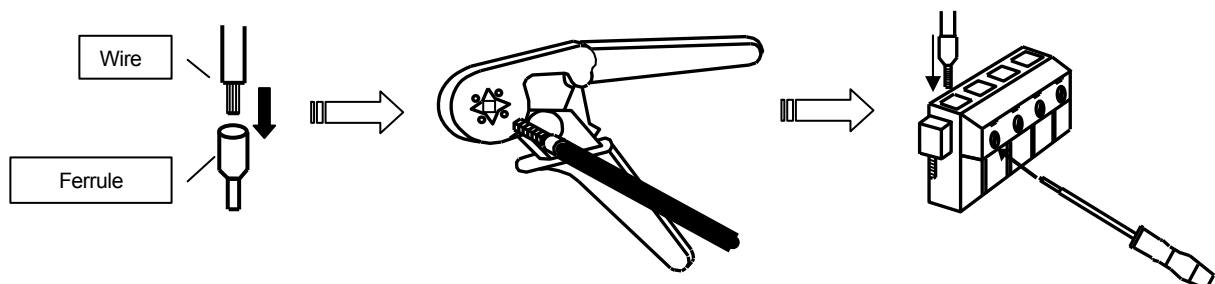

3.Wiring [High voltage circuit: Terminal names and functions]

- Model number of recommended ferrules and crimping tools for various wire sizes
(Manufactured by Phoenix Contact.)

mm ²	AWG	Model number		
		1Pcs/Pkt	1000Pcs/ Pkt	Taped components
0.75 mm ²	18	AI0.75-8GY	AI0.75-8GY-1000	AI0.75-8GY-B (1000Pcs/Pkt)
1.0 mm ²	18	AI1-8RD	AI1-8RD-1000	AI1-8RD-B (1000Pcs/Pkt)
1.5 mm ²	16	AI1.5-8BK	AI1.5-8BK-1000	AI1.5-8BK-B (1000Pcs/Pkt)
2.5 mm ²	14	AI2.5-8BU	AI2.5-8BU-1000	AI2.5-8BU-B (500Pcs/Pkt)

Note) GY: gray, RD: red, BK: black, BU: blue

Crimping tool model number: 0.25mm² to 6mm²: CRIMPFOX UD 6-4, 0.75mm² to 10mm²: CRIMPFOX UD 10-4

■ High voltage circuit terminal; tightening torque

Amplifier type	Terminal marking			
	CNA	CNB	CNC	⊕
RS1□01	[0.5 to 0.6 N·m]			[1.18 N·m] M4 (screw size)
RS1□03				
RS1□05				

Amplifier type	Terminal marking															
	R	S	T	⊖	DL1	DL2	P	RB4	RB1	RB2	U	V	W	r	t	⊕
RS1□10	[1.18 N·m]															
RS1□15	M4 (screw size)															

Amplifier type	Terminal marking															
	R	S	T	⊖	DL1	DL2	P	U	V	W	⊕	RB1	RB2	r	t	
RS1□30	[3.73 N·m] M6 (screw size)										[1.18 N·m] M4 (screw size)					

■ Wiring of the power line UVW

	Servo amplifier terminal number	Servo motor canon type terminal number
Q1AA10*	U	A
Q1AA187*	V	B
Q2AA10*	W	C
Q2AA185*, Q2AA187*	E	D
Q2AA22□□K*		
Q1AA12*	U	D
Q1AA13*		
Q1AA184*	V	E
Q2AA13*		
Q2AA182* to 184*	W	F
Q2AA22□□0*		
R2AA13*	E	G, H
R2AA18350*		
R2AA18450*		
R2AA22*		
R2AA18550*	U	A
R2AA18750*	V	B
R2AA1811KR	W	C
	E	D

3. Wiring [Wiring example of high voltage/ protective circuit]

■ Three-phase 200V RS1□01A·RS1□03A·RS1□05A·RS1□30A

[General output: NPN output]

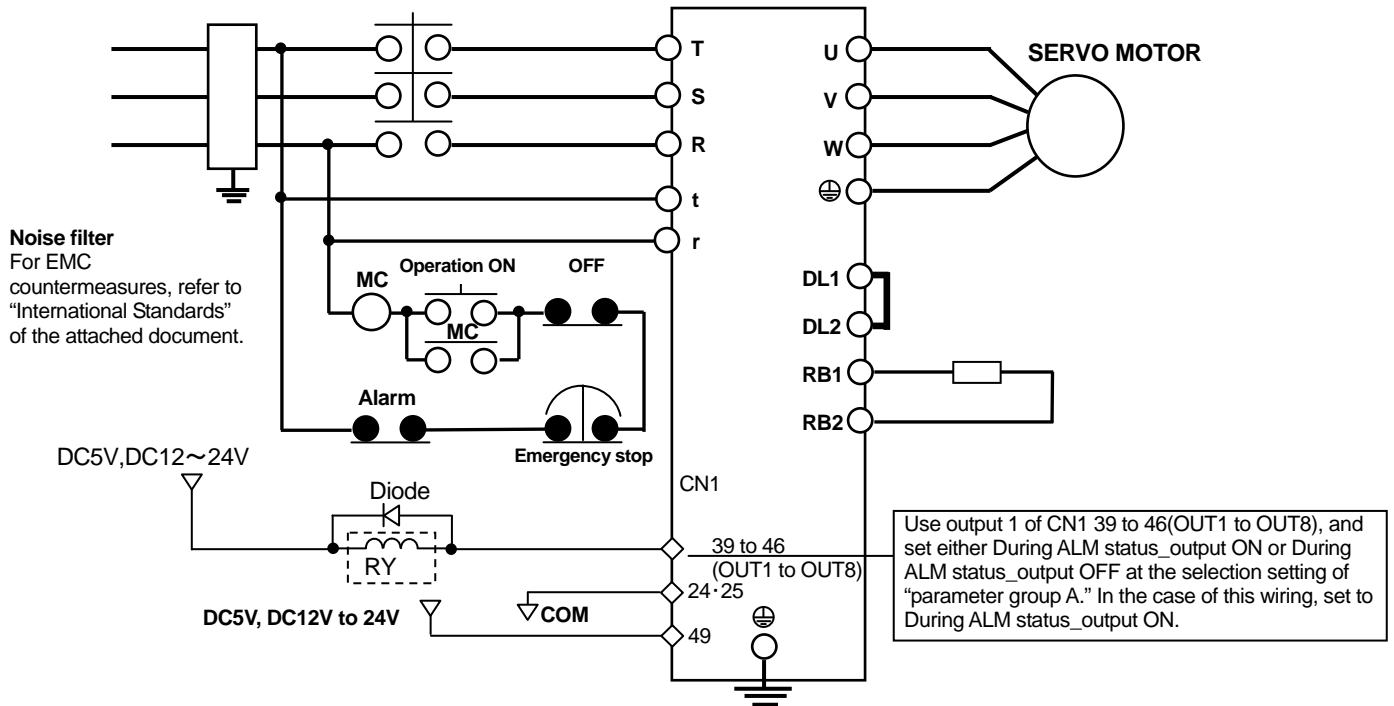

■ Single-phase 200V RS1□01A·RS1□03A·RS1□05A [General output: NPN output]

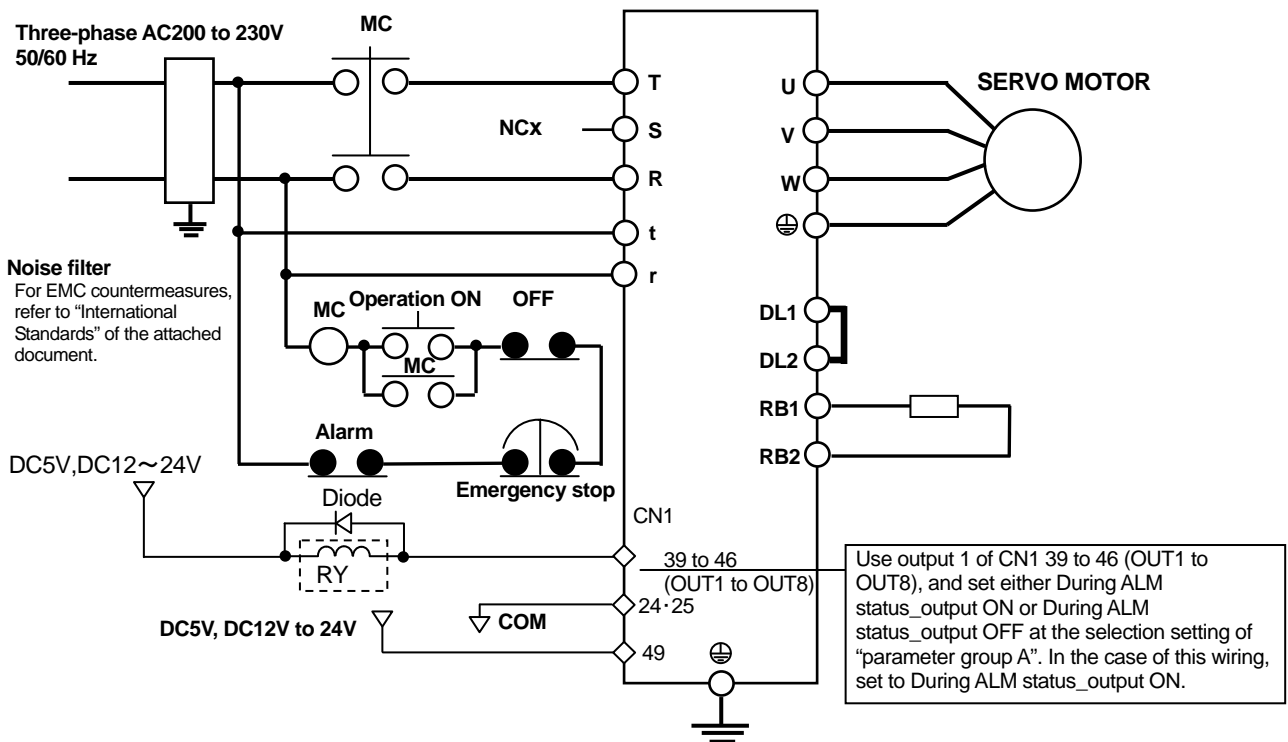

Make sure to install diode as a surge absorber when connecting induction load, such as relay...
to output 39-46 on CN1 (OUT1 to OUT8).

Please carefully install diode so as not to connect polarity of diode. Failure to do this causes servo amplifier malfunction.

3. Wiring [Wiring example of high voltage/ protective circuit]

■ Three-phase 200V RS1□10A·RS1□15A [General output: NPN output]

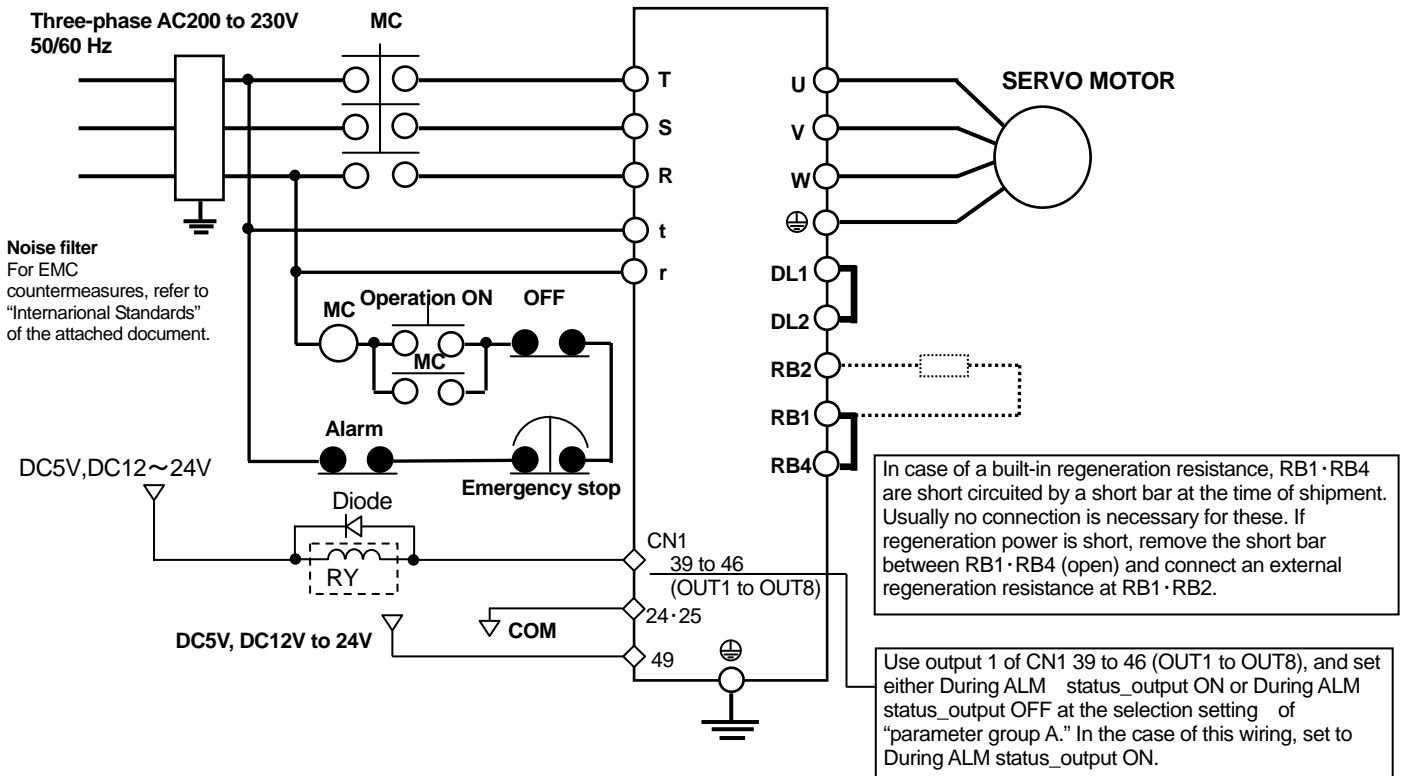

■ Single-phase 100V RS1□01A·RS1□03A [General output: NPN output]

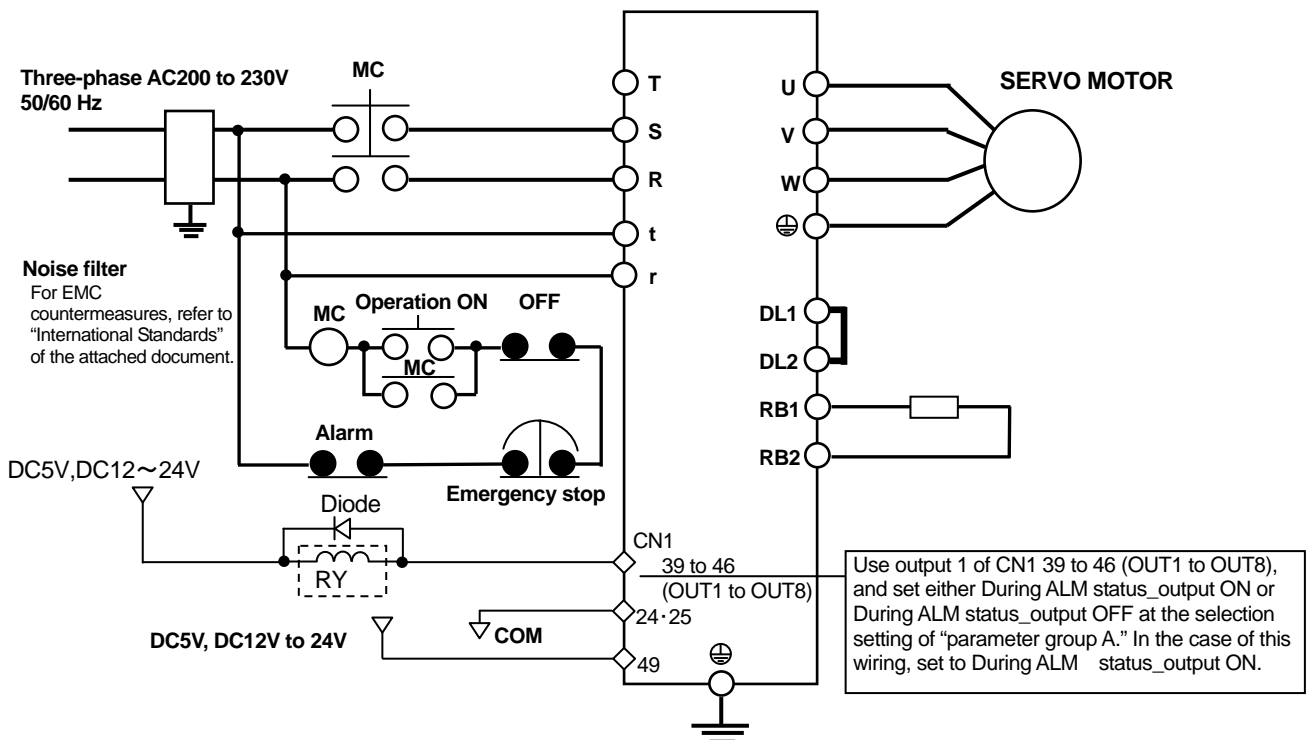

Make sure to install diode as a surge absorber when connecting induction load, such as relay, to output 39-46 on CN1 (OUT1 to OUT8).

Please carefully install diode so as not to connect polarity of diode. Failure to do this causes servo amplifier malfunction.

3. Wiring [Wiring example of high voltage/ protective circuit]

■ Three-phase 200V RS1□01AB·RS1□03AB·RS1□05AB·RS1□30AB [General output : PNP output]

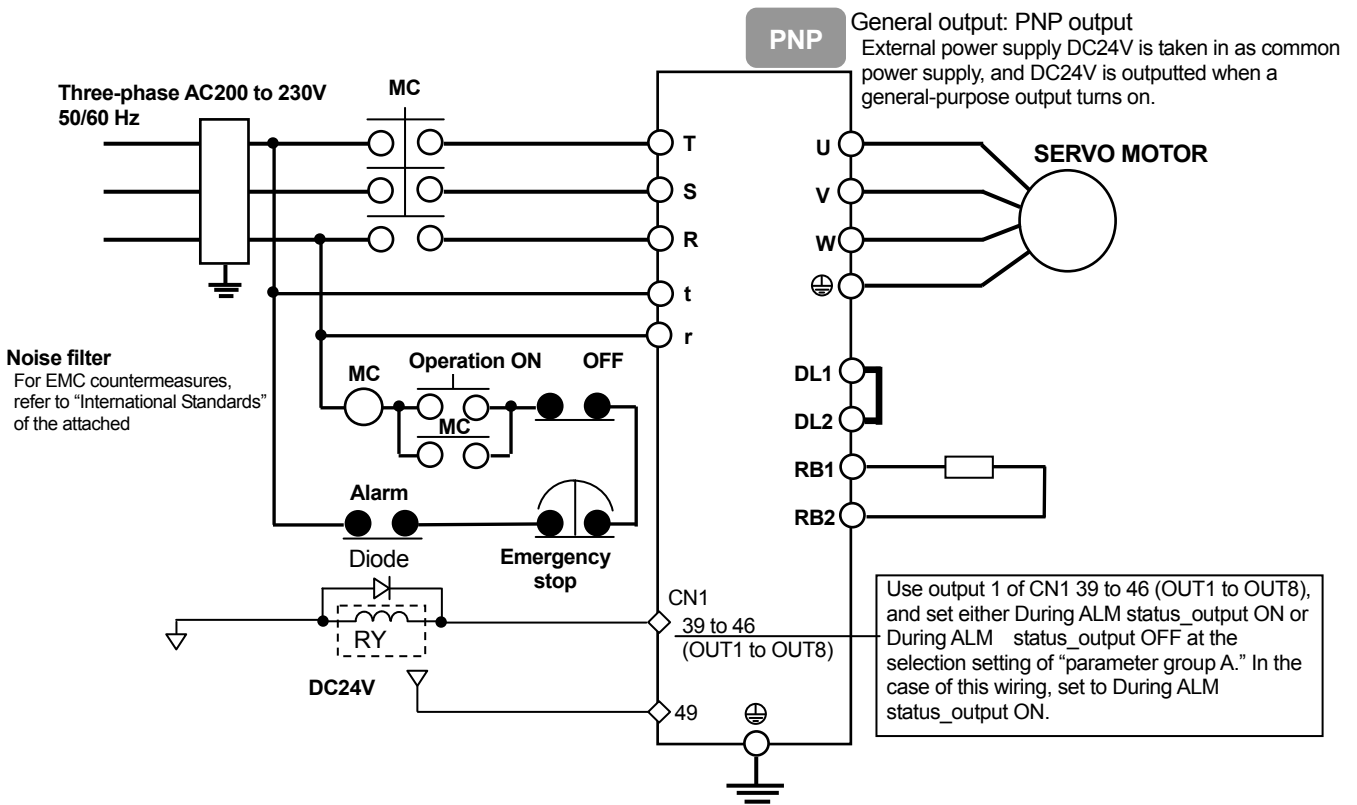

■ Three-phase 200V RS1□01AB·RS1□03AB·RS1□05AB [General output: PNP output]

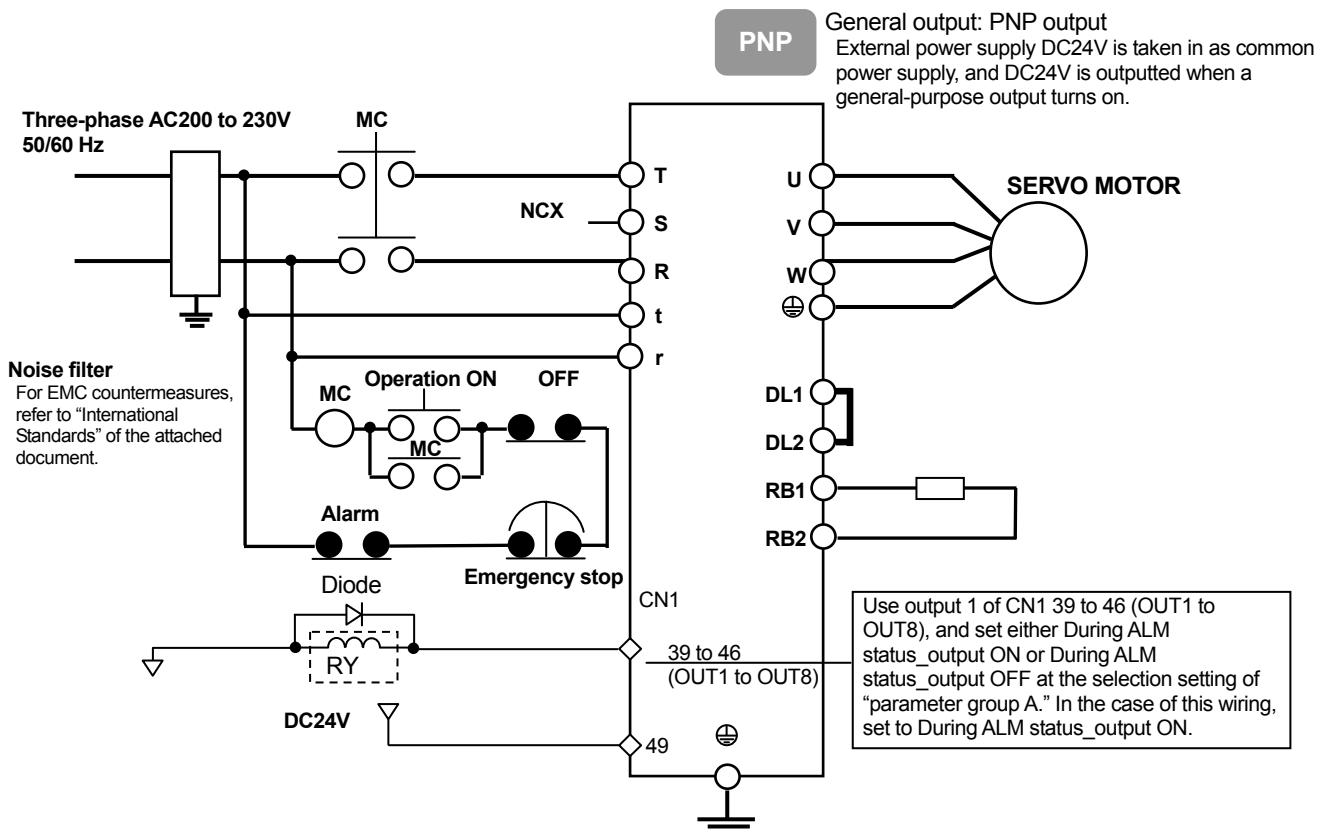

Make sure to install diode as a surge absorber when connecting induction load, such as relay, to output 39-46 on CN1 (OUT1 to OUT8).

Please carefully install diode so as not to connect polarity of diode. Failure to do this causes servo amplifier malfunction.

3. Wiring [Wiring example of high voltage/ protective circuit]

■ Three-phase 200V RS1□10AB·RS1□15AB [General output: PNP output]

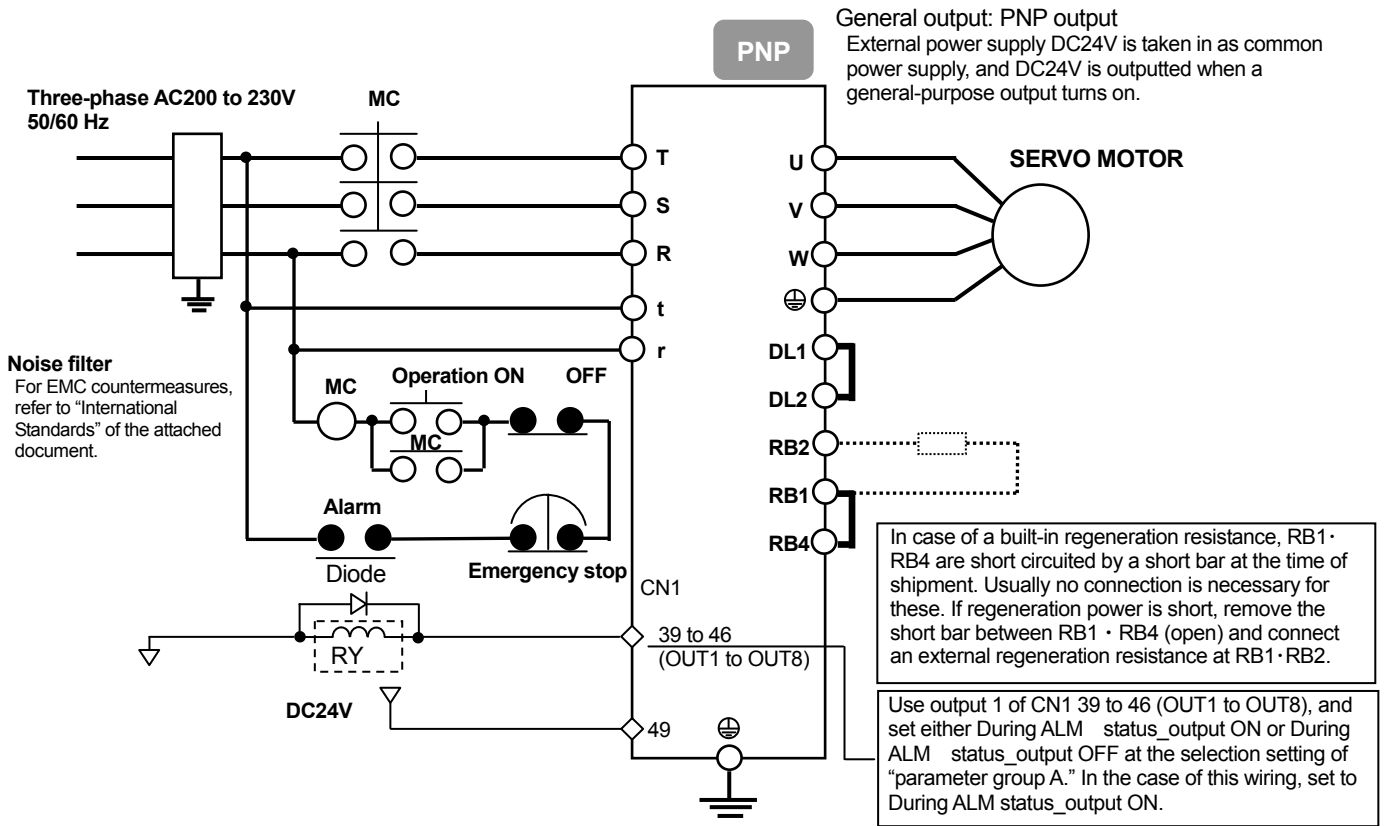

■ Single-phase 100V RS1□01AB·RS1□03AB [General output : PNP output]

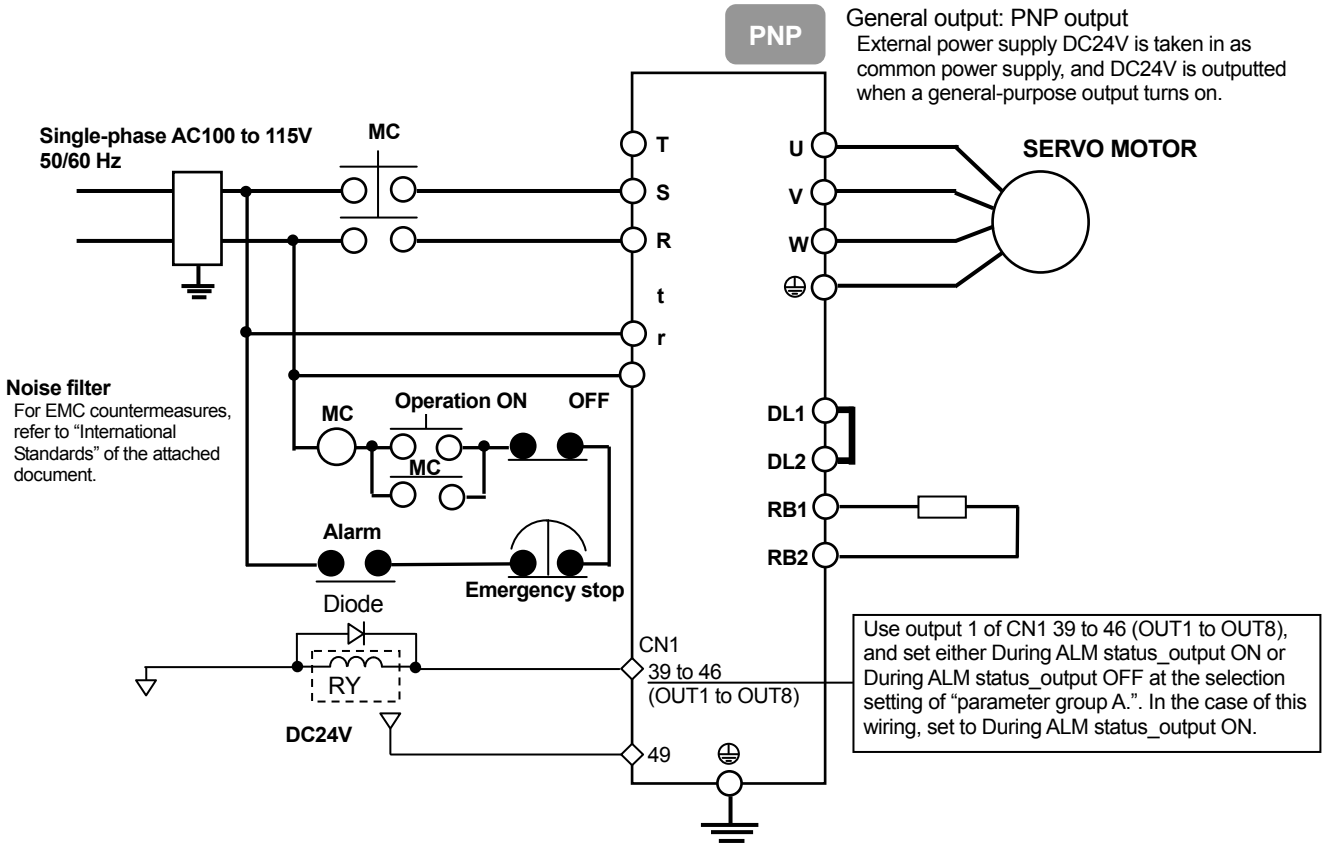

Make sure to install diode as a surge absorber when connecting induction load, such as relay, to output 39-46 on CN1 (OUT1 to OUT8).

Please carefully install diode so as not to connect polarity of diode. Failure to do this causes servo amplifier malfunction.

3.Wiring

[Low voltage circuit/description of CN terminal]

■ Low voltage circuit; terminal name and functions

Terminal name	Terminal code	Description
Upper device input/output signal connector	CN1	Connects the input/output circuit between host device (host controller) and the servo amplifier.
Encoder connector	CN2	Connects the encoder circuit of the servo motor.

■ Connector terminal number

- CN1 10150-3000PE (Soldered side)

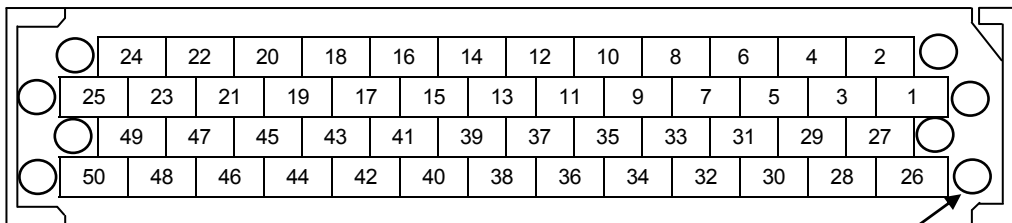

- CN2 10120-3000PE (Soldered side)

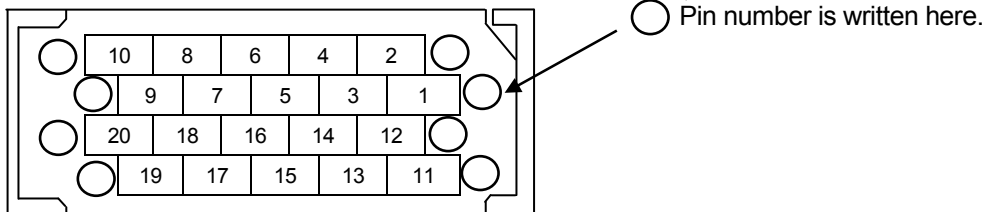

3.Wiring

[Low voltage circuit/ description of CN1 terminal]

■ CN1 connector terminal layout

24	22	20	18	16	14	12	10	8	6	4	2	
OUT-COM*	T-COMP	SG	F-TLA	$\overline{\text{CONT8}}$	$\overline{\text{CONT7}}$	SG	$\overline{\text{PS}}$	$\overline{\text{Z0}}$	$\overline{\text{B0}}$	$\overline{\text{A0}}$	BTN-1	
25	23	21	19	17	15	13	11	9	7	5	3	1
OUT-COM*	SG	V/T-REF	R-TLA	SG	CONT8	CONT7	ZOP	PS	ZO	BO	A0	BTP-1
49	47	45	43	41	39	37	35	33	31	29	27	
OUT-PWR	SG	OUT7	OUT5	OUT3	OUT1	CONT1	CONT3	CONT5	SG	$\overline{\text{R-PC}}$	$\overline{\text{F-PC}}$	
50	48	46	44	42	40	38	36	34	32	30	28	26
IN-COM	SG	OUT8	OUT6	OUT4	OUT2	SG	CONT2	CONT4	CONT6	MON1	R-PC	F-PC

■ CN1 terminal name

Terminal number	Signal name	
1	BTP-1	Battery plus
2	BTN-1	Battery minus
3	A0	A phase position signal output
4	$\overline{\text{A0}}$	/A phase position signal output
5	BO	B phase position signal output
6	$\overline{\text{B0}}$	/B phase position signal output
7	ZO	Z phase position signal output
8	$\overline{\text{Z0}}$	/Z phase position signal output
9	PS	Position data output
10	$\overline{\text{PS}}$	Position data output
11	ZOP	Z phase Position data output
12	SG	Common for pins 3 to 11
17	SG	Common for pins 18·19
18	F-TLA	Analog current limit input
19	R-TLA	Analog current limit input
20	SG	Common for pin 21
21	V-REF	Speed command input
	T-REF	Torque command input
22	T-COMP	Torque compensation input
23	SG	2Common for pin 22
26	F-PC	Command pulse input
27	$\overline{\text{F-PC}}$	Command pulse input
28	R-PC	Command pulse input
29	$\overline{\text{R-PC}}$	Command pulse input
47	SG	Common for pins 26·27
48	SG	Common for pins 28·29

Terminal number	Signal name	
30	MON1	Analog monitor output
31	SG	Common for pin 30
13	CONT7	General input
14	$\overline{\text{CONT7}}$	General input
15	CONT8	General input
16	$\overline{\text{CONT8}}$	General input
38	SG	Common for pins 13 to 16
32	CONT6	General input
33	CONT5	General input
34	CONT4	General input
35	CONT3	General input
36	CONT2	General input
37	CONT1	General input
50	CONT-COM	General input power source
39	OUT1	General output
40	OUT2	General output
41	OUT3	General output
42	OUT4	General output
43	OUT5	General output
44	OUT6	General output
45	OUT7	General output
46	OUT8	General output
49	OUT-PWR	General output power source
24	OUT-COM*	General output Common/NC
25	OUT-COM*	General output Common/NC

Note) 24: OUT-COM*, 25: OUT-COM*
In the case of the PNP output, it is set to NC.

PNP

General output: PNP output
External power supply DC24V is taken in as common power supply, and DC24V is outputted when a general-purpose output turns on.

3.Wiring

[Low voltage circuit/ CN1 overall wiring]

■ CN1 Connector terminal layout [General output: NPN output]

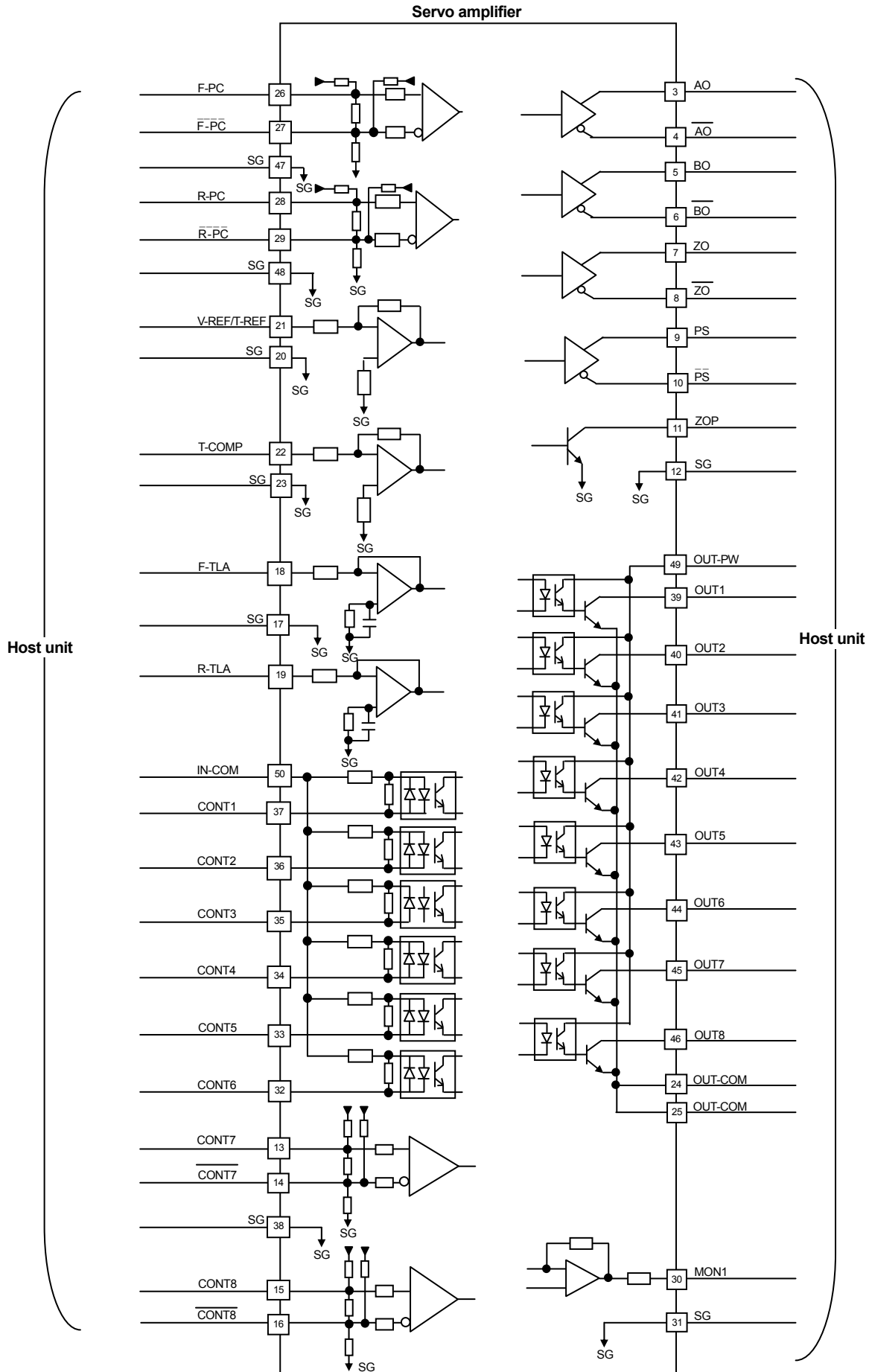

3.Wiring

[Low voltage circuit/ CN1 overall wiring]

PNP

■ CN1 Connector terminal layout [General output: PNP output]

General output: PNP output
 External power supply DC24V is taken in as common power supply, and DC24V is outputted when a general-purpose output turns on.

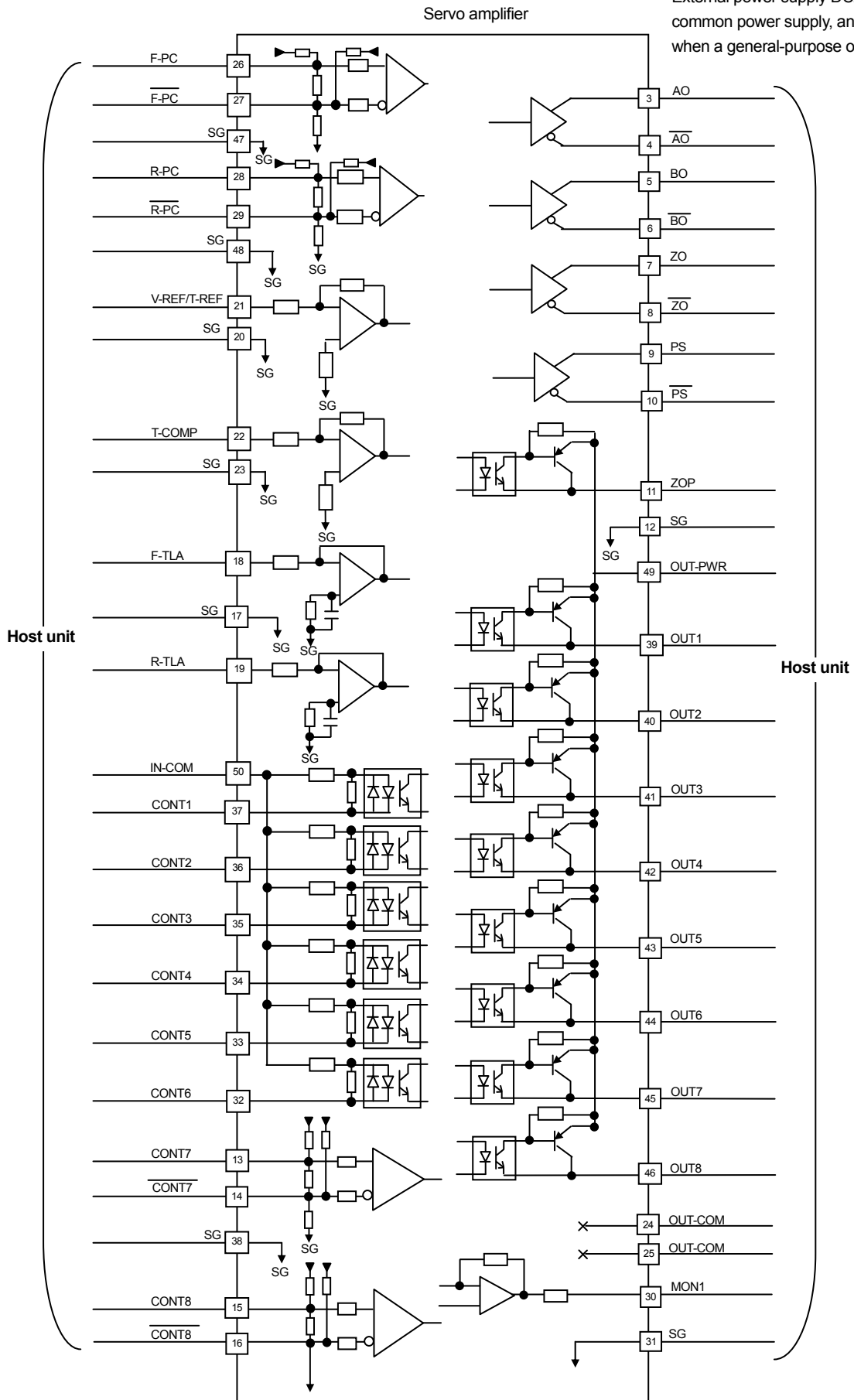

3.Wiring

[Low voltage circuit/wiring example of CN1 input circuit]

■ Connection example with analog input circuit

● Analog input circuit

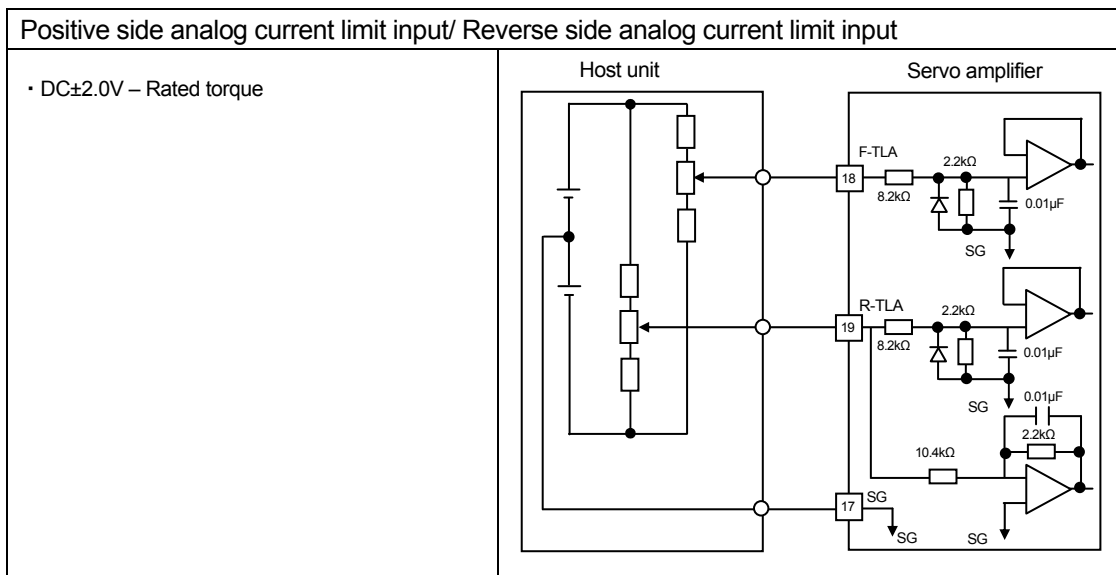
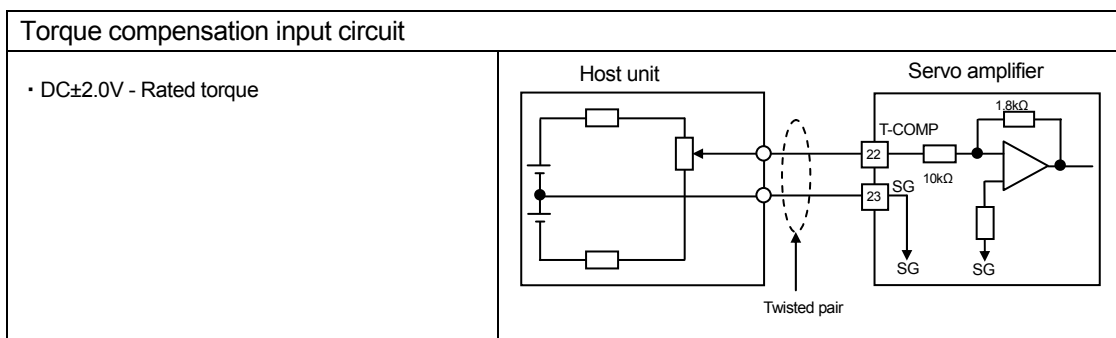
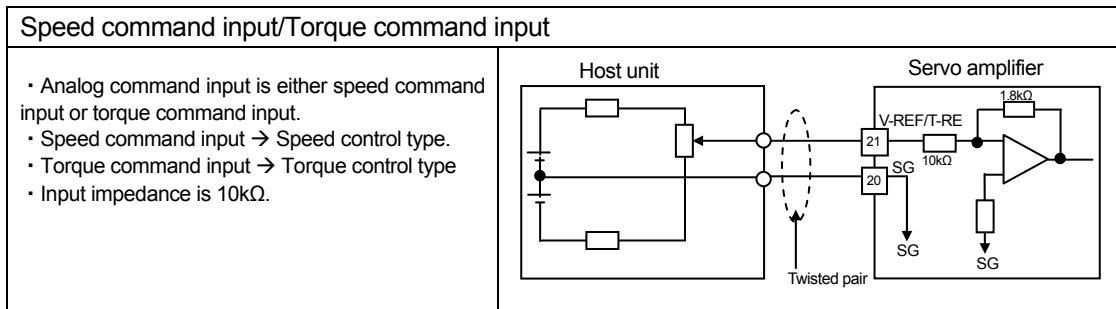

3.Wiring

[Low voltage circuit/wiring example of CN1 input circuit]

- Position command input circuit [Input circuit : Line receiver]

Command pulse input-Upper device line driver output

- Connected with line driver.
- Applicable line driver: HD26C31 or equivalent manufactured by HITACHI.
- Position command input is command pulse input.
- Command pulse input → Position control type
- Three types of command input pulse.
 - [Positive pulse+ Reverse pulse]
 - Maximum 5M pulse/second
 - [Code + pulse train]
 - Maximum 5M pulse/second
 - [90°-phase difference two phase pulse train]
 - Maximum 2.5M pulse/second
- Make sure to connect SG. If not, malfunction due to noise or damage may be caused.

Command pulse input-Upper device open collector output

- Connected with open collector transistor circuit.
- Position command input is command pulse input.
- Command pulse input → Position control type
- Three types of command input pulse.
 - [Forward pulse + Reverse pulse]
 - [Symbol + pulse train]
 - [90°-phase difference two phase pulse train]
- Maximum pulse frequency: 150kHz

- Battery input circuit

- Connected with back up battery when absolute encoder is in use.
- If a battery is built-in the Servo amplifier, no connection is necessary here.

3. Wiring

[Low voltage circuit/wiring example of CN1 input circuit]

■ Connection example with generic input circuit

● Generic input circuit CONT1 to CONT6

[Input circuit: Bi-directional photo coupler]

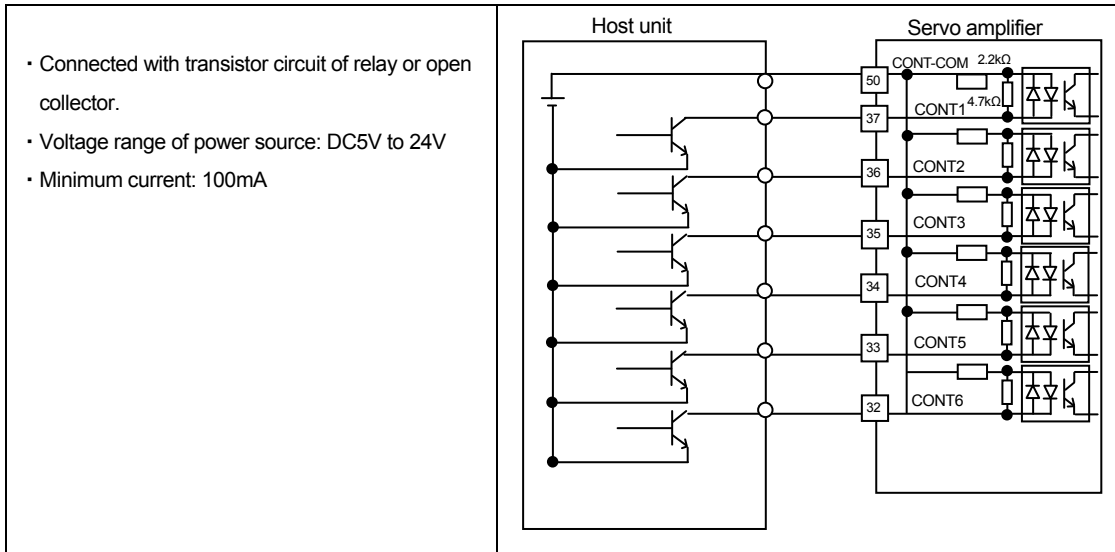

● Generic input circuit CONT7·CONT8

[Input circuit: Line receiver]

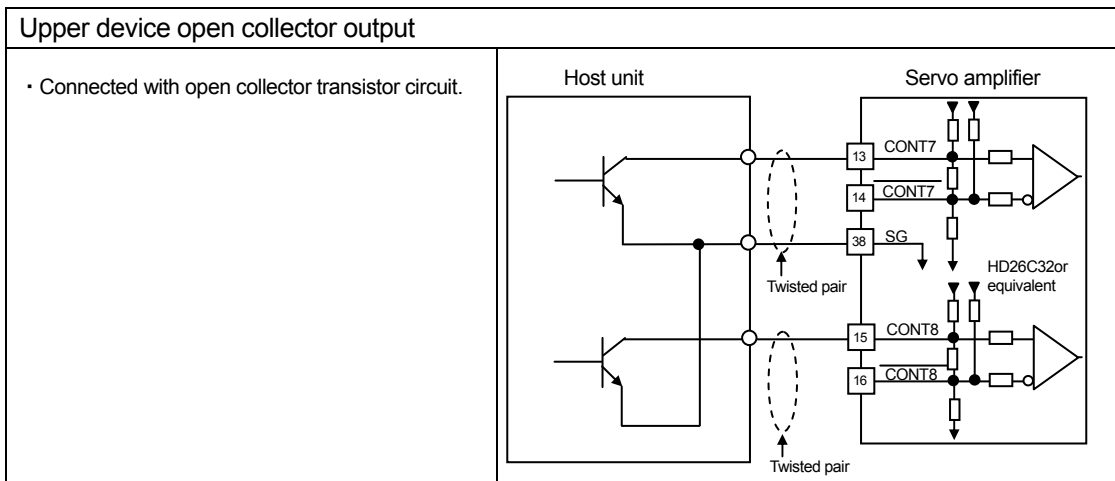
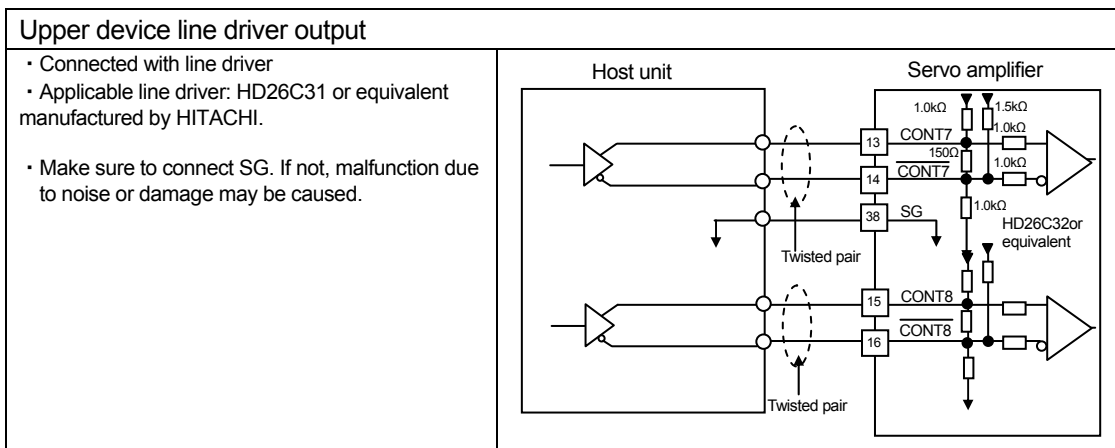

3.Wiring

[Low voltage circuit/ wiring example of CN1 output circuit]

■ Connection example with position signal output circuit

● Incremental pulse signal output circuit

[output circuit: line driver]

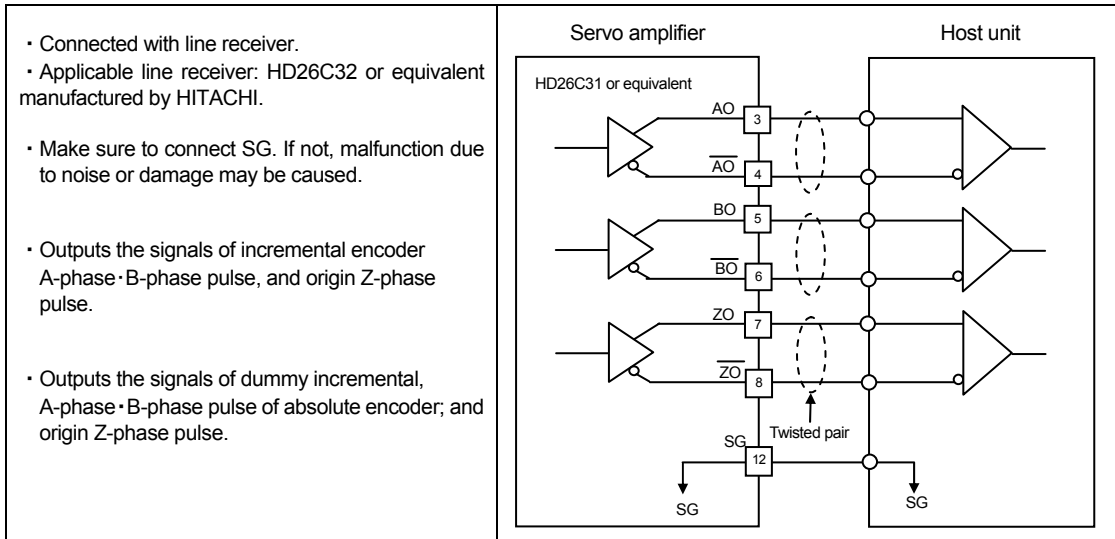

● Absolute position data output circuit

[output circuit: line driver]

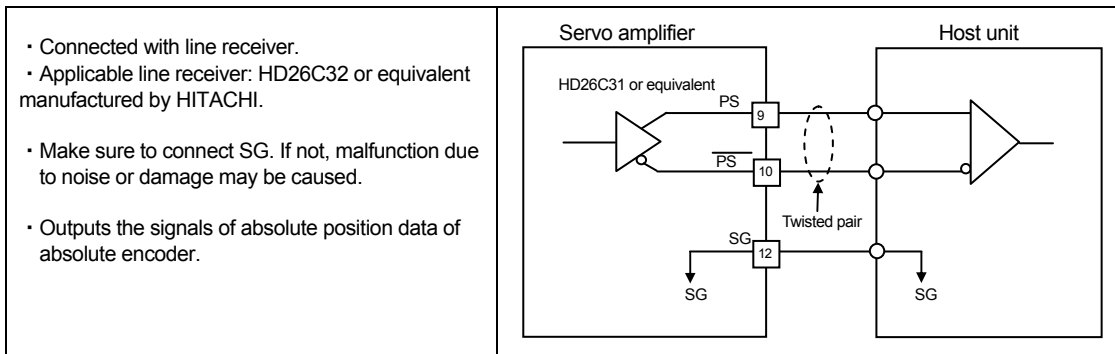

● Origin Z phase output circuit

[output circuit: open collector NPN output]

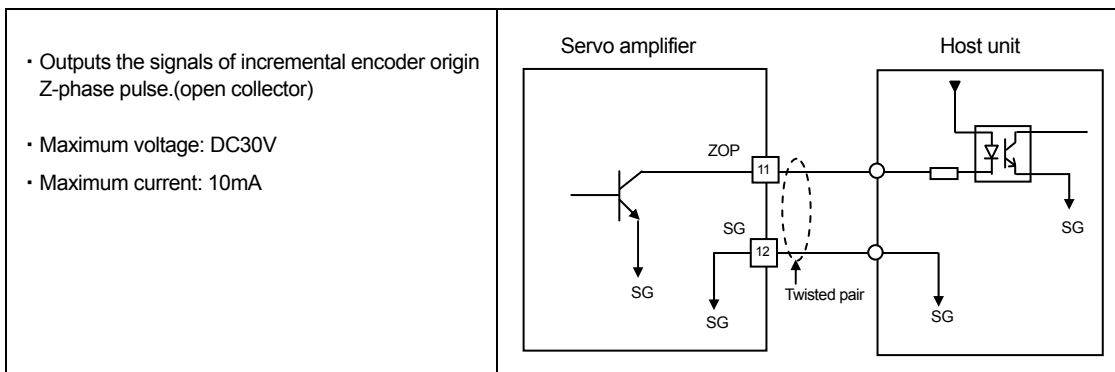

3.Wiring

[Low voltage circuit/ wiring example of CN1 output circuit]

● Origin Z phase output circuit [output circuit: open collector PNP output]

PNP

General output: PNP output
 External power supply DC24V is taken in as common power supply, and DC24V is outputted when a general-purpose output turns on.

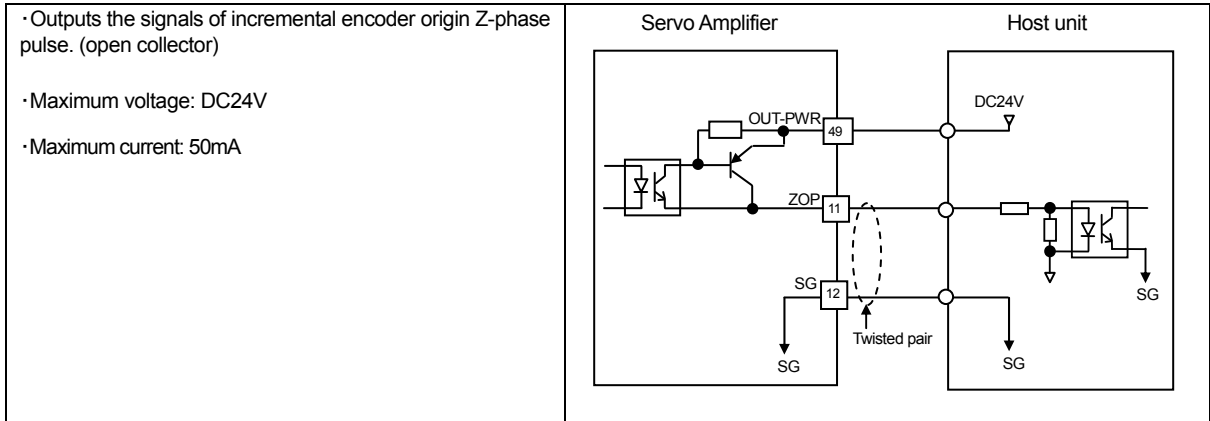

- Outputs the signals of incremental encoder origin Z-phase pulse. (open collector)
- Maximum voltage: DC24V
- Maximum current: 50mA

■ Connection example with generic output circuit

● Generic output circuit OUT1 to OUT8

[Output circuit: open collector NPN output]

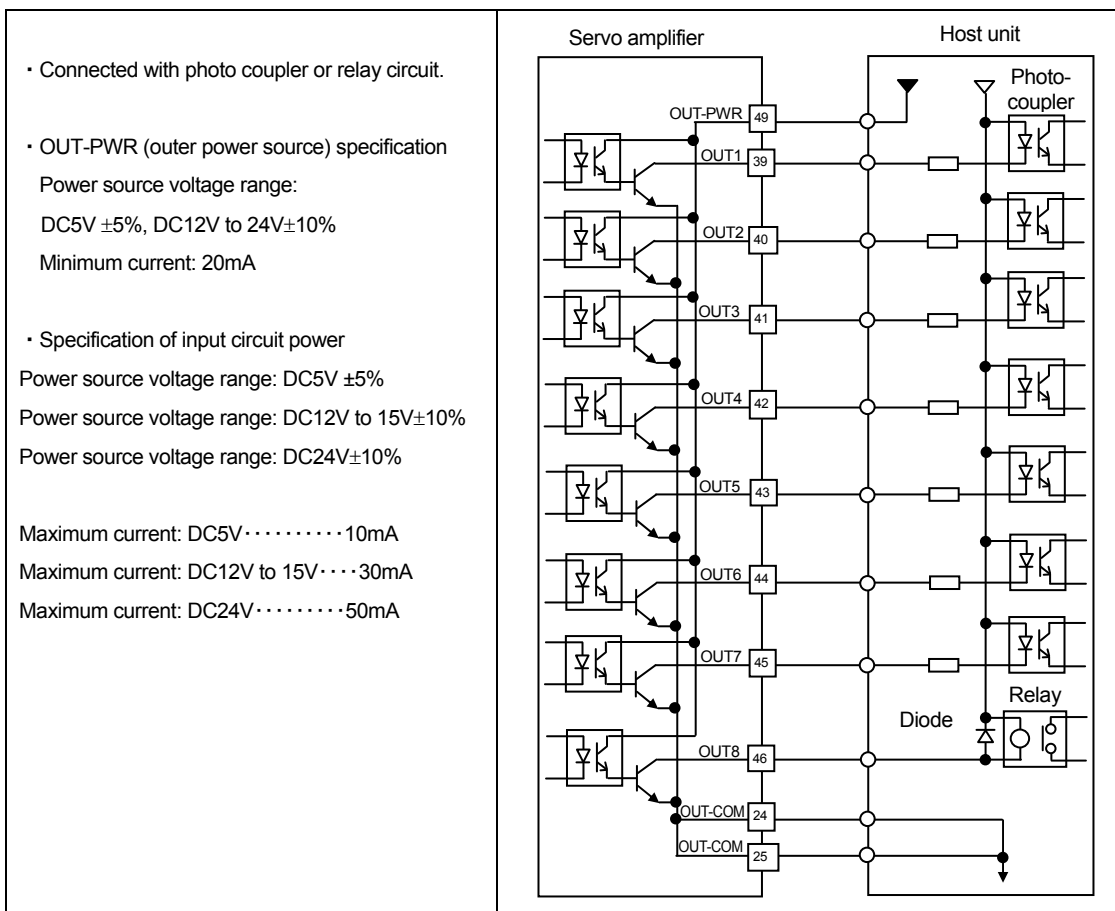

- Connected with photo coupler or relay circuit.
- OUT-PWR (outer power source) specification
 Power source voltage range:
 DC5V $\pm 5\%$, DC12V to 24V $\pm 10\%$
 Minimum current: 20mA
- Specification of input circuit power
 Power source voltage range: DC5V $\pm 5\%$
 Power source voltage range: DC12V to 15V $\pm 10\%$
 Power source voltage range: DC24V $\pm 10\%$
 Maximum current: DC5V.....10mA
 Maximum current: DC12V to 15V.....30mA
 Maximum current: DC24V.....50mA

 Make sure to install diode as a surge absorber when connecting induction load, such as relay, to general (-purpose) output.
 Please carefully install diode so as not to connect polarity of diode. Failure to do this causes servo amplifier malfunction.

3.Wiring

[Low voltage circuit/ wiring example of CN1 output circuit]

- General output circuit OUT1 to OUT8 [output circuit: open collector PNP output]

PNP

General output: PNP output
 External power supply DC24V is taken in as common power supply, and DC24V is outputted when a general-purpose output turns on.

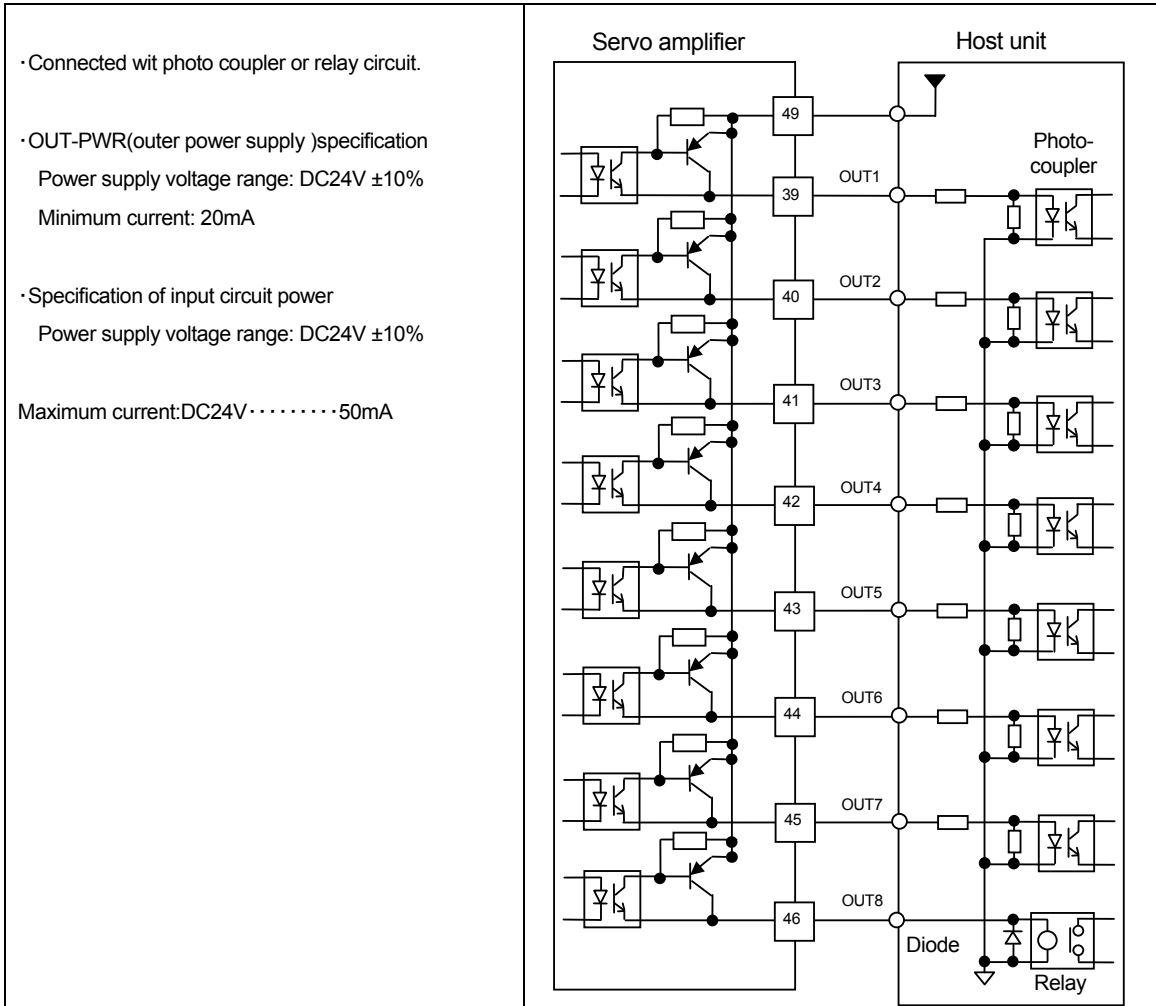

 Make sure to install diode as a surge absorber when connecting induction load, such as relay, to general (-purpose) output.
 Please carefully install diode so as not to connect polarity of diode. Failure to do this causes servo amplifier malfunction.

■ Connection example with analog output circuit

- Analog monitor output circuit

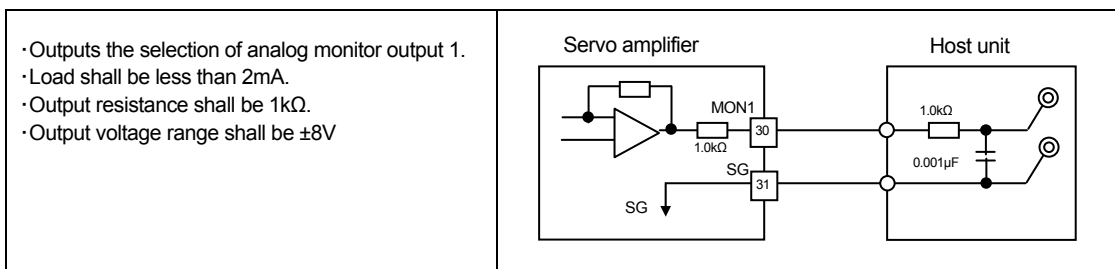

3. Wiring [Low voltage circuit/vCN2 wiring · wire-saving incremental encoder]

■ CN2 terminal layout

10	8	6	4	2	
	9	7	5	3	1
20	18	16	14	12	
	19	17	15	13	11

■ Wiring for wire-saving incremental encoder

Wire-saving incremental encoder				
Terminal No. of CN2 of servo amplifier	Signal name	Description	Servo motor lead type wire color	Servo motor canon type terminal number
1	-	-	-	-
2	-	-	-	-
3	A	A-phase position signal output	blue	A
4	\bar{A}		brown	D
5	B	B-phase position signal output	green	B
6	\bar{B}		purple	E
7	Z	Z phase position signal output	white	F
8	\bar{Z}		yellow	G
9	5V	5V-power supply	(red)	(J)
10	SG	5V-power supply common	(black)	(N)
11	SG	5V-power supply common	(black)	(N)
12	5V	5V-power supply	(red)	(J)
13	-	-	-	-
14	-	-	-	-
15	-	-	-	-
16	SG	5V-power supply common	(black)	(N)
17	5V	5V-power supply	(red)	(J)
18	SG	5V-power supply common	(black)	(N)
19	5V	5V-power supply	red	J
20	SG	5V-power supply common	black	N
G Plate	shield wire			H

- Refer to page 3-30 for how to process the shield wires.
- The number of power terminals for servo motor encoder connections varies depending on the encoder cable length. Refer to the following table.

Encoder cable length	Power connection (CN2) terminal number for servo motor encoder	
	5V-power supply terminal number	5V-power supply common terminal number
Less than 5m	19	20
Less than 10m	19, 17	20, 18
Less than 20m	19, 17, 12	20, 18, 11
Less than 30m	19, 17, 12, 9	20, 18, 11, 16, 10

- Use twisted pair and outer insulated shield cables.
- CN2 plug: 10120-3000PE
- CN2 shell: 10320-52A0-008
- Servo motor encoder: canon plug
 - JA06A-20-29S-J1-R
 - JA06A-20-29S-J1-EB-R
 - JA08A-20-29S-J1-EB-R
 - N/MS3108B20-29S
 - N/MS3106B20-29S

3. Wiring

[Low voltage circuit/ CN2 wiring· battery-backup absolute encoder and others]

■ CN2 terminal layout

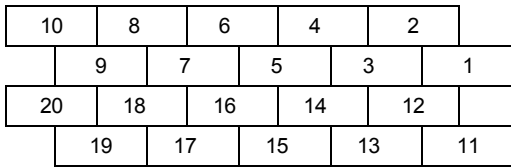

■ Wiring for Battery backup method absolute encoder/Absolute encoder without battery/Absolute encoder for incremental system

Battery backup method absolute encoder/Absolute encoder without battery/Absolute encoder for incremental system						
Terminal No. of CN2 of servo amplifier	Signal name	Description	Servo motor lead type wire color	Q1,Q2,Q4 servo motor canon type terminal number	R2 servo motor canon type terminal number	
1	BAT+	Battery	pink	T	8	No battery wiring necessary for Absolute encoder without battery/Absolute encoder for incremental system
2	BAT-		purple	S	4	
3	-	-	-	-	-	
4						
5						
6						
7						
8	5V	5V-power supply	(red)	(H)	(9)	
9						
10	SG	5V-power supply common	(black)	(G)	(10)	
11	SG	5V-power supply common	(black)	(G)	(10)	
12	5V	5V-power supply	(red)	(H)	(9)	
13	ES	Position data output	brown	E	1	
14	ES		blue	F	2	
15	-	-	-	-	-	
16	SG	5V-power supply common	(black)	(G)	(10)	
17	5V	5V-power supply	(red)	(H)	(9)	
18	SG	5V-power supply common	(black)	(G)	(10)	
19	5V	5V-power supply	red	H	9	
20	SG	5V-power supply common	black	G	10	
G Plate	Shielded wire			J	-	

- Refer to page 3-30 for how to process the shield wires.
- The number of power terminals for servo motor encoder connections varies depending on the encoder cable length. Refer to the following table.

Encoder cable length	Power connection (CN2) terminal number for servo motor encoder	
	5V-power supply terminal number	5V-power supply common terminal number
Less than 10m	19	20
Less than 25m	19, 17	20, 18
Less than 40m	19, 17, 12	20, 18, 11

- Use twisted pair and outer insulated shield cables.
- CN 2 plug: 10120-3000PE
- CN 2 shell: 10320-52A0-008
- Servo motor encoder: canon plug
 - Q1,Q2,Q4 Motor
 - JA06A-20-29S-J1-R
 - JA06A-20-29S-J1-EB-R
 - JA08A-20-29S-J1-EB-R
 - N/MS3108B20-29S
 - N/MS3106B20-29S
 - R2 Motor
 - 2DS10SL*-R (Plug)
 - JN2FS10SL*-R (Plug)
 - JN1-22-2*S-PKG100 (Contact)
 - JN1-22-2*S-R-PKG100 (Contact)

3. Wiring

[Low voltage circuit/ CN2 wiring - absolute encoder with incremental output]

■ CN2 terminal layout

10	8	6	4	2
9	7	5	3	1
20	18	16	14	12
19	17	15	13	11

■ Absolute encoder with incremental output

Absolute encoder with incremental output				
Terminal No. of CN2 of servo amplifier	Signal name	Description	Servo motor lead type wire color	Servo motor canon type terminal number
1	BAT+	Battery	light orange or clear	T
2	BAT-		brown	S
3	A	A phase position signal output	pink	A
4	\bar{A}		red	B
5	B	B phase position signal output	blue	C
6	\bar{B}		green	D
7	Z	Z phase position signal output	yellow	K
8	\bar{Z}		Orange	L
9	5V	5V-power supply	(white)	(H)
10	SG	5V-power supply common	(black)	(G)
11	SG	5V-power supply common	(black)	(G)
12	5V	5V-power supply	(white)	(H)
13	PS	Position data output	Pale blue	E
14	PS		purple	F
15	ECLR	Clear signal	Dark green or light green	R
16	SG	5V-power supply common	(black)	(G)
17	5V	5V-power supply	(white)	(H)
18	SG	5V-power supply common	(black)	(G)
19	5V	5V-power supply	white	H
20	SG	5V-power supply common	black	G
G Plate		shield wire		J

- Refer to page 3-30 for how to process the shield wires.
- The number of power terminals for servo motor encoder connections varies depending on the encoder cable length. Refer to the following table.

Encoder cable length	Power connection (CN2) terminal number for servo motor encoder	
	5V-power supply terminal number	5V-power supply common terminal number
Less than 5m	19	20, 16
Less than 10m	19, 17	20, 16, 18
Less than 20m	19, 17, 12	20, 16, 18, 11
Less than 30m	19, 17, 12, 9	20, 16, 18, 11, 10

- Use twisted pair and outer insulation shield cables.
- CN2 plug : 10120-3000PE
- CN2 shell : 10320-52A0-008
- Servo motor encoder : canon plug
 - JA06A-20-29S-J1-R
 - JA06A-20-29S-J1-EB-R
 - JA08A-20-29S-J1-EB-R
 - N/MS3108B20-29S
 - N/MS3106B20-29S

3. Wiring [Low voltage circuit/ CN2 wiring·request method absolute encoder]

■ CN2 terminal layout

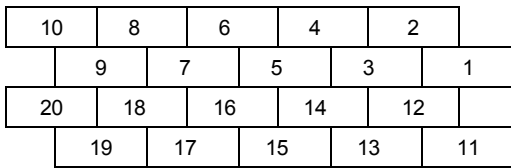

■ Request method absolute encoder

Request method absolute encoder				
Terminal No. of CN2 of servo amplifier	Signal name	Description	Servo motor lead type wire color	Servo motor canon type terminal number
1	-	-	-	-
2	-	-	-	-
3	REQ+	Requested Signal	purple or orange	N
4	REQ-		green	P
5	-	-	-	-
6	-	-	-	-
7	-	-	-	-
8	-	-	-	-
9	5V	5V-power supply	(red)	(H)
10	SG	5V-power supply common	(black)	(G)
11	SG	5V-power supply common	(black)	(G)
12	5V	5V-power supply	(red)	(H)
13	PS	Position data output	brown	E
14	PS		blue	F
15	ECLR	Clear signal	white	R
16	SG	5V-power supply common	yellow	(G)
17	5V	5V-power supply	(red)	(H)
18	SG	5V-power supply common	(black)	(G)
19	5V	5V-power supply	red	H
20	SG	5V-power supply common	black	G
G Plate	shield wire			J

- Refer to page 3-30 for how to process the shield wires.
- The number of power terminals for servo motor encoder connections varies depending on the encoder cable length. Refer to the following table.

Encoder cable length	Power connection (CN2) terminal number for servo motor encoder	
	5V-power supply terminal number	5V-power supply common terminal number
Less than 5m	19,9	20,16,10
Less than 30m	19,9,17,12	20,16,10,18,11

- Use twisted pair and outer insulated shield cables.
- CN 2 plug: 10120-3000PE
- CN 2 shell: 10320-52A0-008
- Servo motor encoder: canon plug
 - JA06A-20-29S-J1-R
 - JA06A-20-29S-J1-EB-R
 - JA08A-20-29S-J1-EB-R
 - N/MS3108B20-29S
 - N/MS3106B20-29S

3.Wiring

[Low voltage circuit/ CN2 wiring·Fully-closed control]

Fully-closed

■ Wiring between servo motor encoder and external encoder at full-closed control

● When using an absolute type encoder

Servo amplifier model: RS1□□□AA

Battery backup method absolute encoder		
Terminal No.	Signal name	Description
1	BAT+	Battery
2	BAT-	
9	5V	5V power source
10	SG	5V power source common
11	SG	5V power source common
12	5V	5V power source
13	ES	Position data output
14	ES	
15	-	-
16	SG	5V power source common
17	5V	5V power source
18	SG	5V power source common
19	5V	5V power source
20	SG	5V power source common
Terminal No.	Signal name	External encoder signal
3	A	A phase position signal output
4	Ā	
5	B	B phase position signal output
6	B̄	
7	Z	Z phase position signal output
8	Z̄	

Servo amplifier model: RS1□□□AA

Absolute encoder without battery/Absolute encoder for incremental system		
Terminal No.	Signal name	Description
1	-	-
2	-	-
9	5V	5V power source
10	SG	5V power source common
11	SG	5V power source common
12	5V	5V power source
13	ES	Position data output
14	ES	
15	-	-
16	SG	5V power source common
17	5V	5V power source
18	SG	5V power source common
19	5V	5V power source
20	SG	5V power source common
Terminal No.	Signal name	External encoder signal
3	A	A phase position signal output
4	Ā	
5	B	B phase position signal output
6	B̄	
7	Z	Z phase position signal output
8	Z̄	

Please note that the power supply for external encoder signals is user-prepared item.

Please note that the external encoder's signal ground (SG) shall connect to the signal ground (SG) of the servo amplifier CN2.

● When using an incremental type encoder

Servo amplifier model: RS1□□□AT

Wire-saving incremental encoder		
Terminal No.	Signal name	Description
1	-	-
2	-	-
3	A0	A phase position signal output
4	Ā0	
5	B0	B phase position signal output
6	B̄0	
7	Z0	Z phase position signal output
8	Z̄0	
11	SG	5V power source common
12	5V	5V power source
17	5V	5V power source
18	SG	5V power source common
19	5V	5V power source
20	SG	5V power source common
Terminal No.	Signal name	External encoder signal
9	A	A phase position signal output
10	Ā	
13	B	B phase position signal output
14	B̄	
15	Z	Z phase position signal output
16	Z̄	

Please note that the power supply for external encoder signal is user prepared item.

The external encoder's signal ground (SG) must be connected to the signal ground (SG) of the servo amplifier CN2.

3.Wiring

[Power supply · peripherals]

■ Power Capacity · Peripherals examples

Input Voltage	Servo amplifier capacity RS1 * □□□A	Servo motor model number	Rated Output(W)	Rated main power supply (KVA)	Power supply control (VA)	Circuit breaker	Noise filter (EMC corresponding time)	Electro magnetic contactor		
AC 200V	01	Q1AA04003D	30	0.2	40	NF30 shape 10A Manufactured by Mitsubishi Ltd.				
		Q1AA04005D	50	0.2						
		Q1AA04010D	100	0.3						
		Q1AA06020D	200	0.8						
		Q2AA04006D	60	0.3						
		Q2AA04010D	100	0.4						
		Q2AA05005D	50	0.3						
		Q2AA05010D	100	0.4						
		Q2AA05020D	200	0.8						
		Q2AA07020D	200	0.8						
		Q2AA07030D	300	1.0						
		R2AA04003F	30	0.2						
		R2AA04005F	50	0.2						
		R2AA04010F	100	0.4						
	R2AA06010F	100	0.4							
	R2AA06020F	200	0.8							
	R2AA08020F	200	0.8							
	03	Q1AA06040D	400	1.0		NF30 shape 10A Manufactured by Mitsubishi Ltd.	RF3020-DLC Manufactured by RASMI	S-N10 Manufactured by Mitsubishi Ltd.		
		Q1AA07075D	750	1.7						
		Q2AA07040D	400	1.3						
		Q2AA07050D	500	1.5						
		Q2AA08050D	500	1.5						
		Q2AA13050H	500	1.4						
		R2AA06040F	400	1.0						
		R2AA08040F	400	1.0						
		R2AA08075F	750	1.7						
		R2AAB8100H	1000	2.0						
		R2AA10075F	750	1.7						
		R2AA13050H	550	1.2						
		R2AA13050D	550	1.5						
		R2AA13120B	1200	2.2						
	05	Q1AA10100D	1000	2.5		NF30 shape 15A Manufactured by Mitsubishi Ltd.				
		Q1AA10150D	1500	3.0						
		Q1AA12100D	1000	2.5						
		Q2AA08075D	750	2.0						
		Q2AA08100D	1000	2.5						
		Q2AA10100H	1000	2.5						
		Q2AA10150H	1500	3.0						
		Q2AA13100H	1000	2.5						
		Q2AA13150H	1500	3.0						
		R2AAB8075F	750	1.7						
		R2AAB8100F	1000	2.5						
		R2AA10100F	1000	2.3						
		R2AA13120D	1200	2.7						
		R2AA13120L	1200	2.8						
	R2AA13180H	1800	3.6							
	R2AA13200L	2000	4.0							
	10	Q1AA10200D	2000	4.0		NF50 shape 30A Manufactured by Mitsubishi Ltd.	RF3020-DLC Manufactured by RASMI	S-N18 Manufactured by Mitsubishi Ltd.		
		Q1AA10250D	2500	4.2						
		Q1AA12200D	2000	4.0						
		Q1AA12300D	3000	5.0						
		Q1AA13300D	3000	5.0						
Q2AA13200H		2000	5.0							
Q2AA18200H		2000	5.0							
R2AA13180D		1800	4.0							
R2AA13200D		2000	5.0							
R2AA18350L		3500	6.0							
R2AA22350L		3500	6.0							
15		Q1AA13400D	4000	6.7	NF50 shape 50A Manufactured by Mitsubishi Ltd.				RF3030-DLC Manufactured by RASMI	S-N35 Manufactured by Mitsubishi Ltd.
		Q1AA13500D	5000	8.3						
		Q1AA18450M	4500	7.4						
	Q2AA18350H	3500	6.9							
	Q2AA18450H	4500	7.4							
	Q2AA18550R	5500	8.4							
	Q2AA22550B	5500	10.1							
	Q2AA22700S	7000	12.2							
	R2AA18350D	3500	7.0							
	R2AA18450H	4500	7.4							
	R2AA18550R	5500	8.4	NF100 shape 75A Manufactured by Mitsubishi Ltd.	3SUP-HK50-ER-6B Manufactured by Okaya Ltd. FS5559-35-33 Manufactured by SCHAFFNER	S-N50 Manufactured by Mitsubishi Ltd.				
	R2AA22500L	5000	9.6							

3.Wiring

[Power supply · peripherals]

Servo amplifier capacity RS1*□□A	Servo motor model number	Rated Output(W)	Rated main power supply (KVA)	Power supply control (VA)	Circuit breaker	Noise filter (EMC corresponding time)	Electro magnetic contactor	Electro magnetic contactor
AC 200V	30	Q1AA18750H	7500	12.6	40	NF100 shape 100A Manufactured by Mitsubishi Ltd.	RF3070-DLC Manufactured by RASMI	S-N65 Manufactured by Mitsubishi Ltd.
		Q2AA18550H	5500	10.1				
		Q2AA18750L	7500	12.6				
		Q2AA2211KV	11000	15.7				
		Q2AA2215KV	15000	21.4				
		R2AA18550H	5500	9.3				
		R2AA18750H	7500	11.6				
R2AA1811KR	11000	16.0						

Servo amplifier capacity RS1*□□A	Servo motor model number	Rated Output(W)	Rated main power supply (KVA)	Power supply control (VA)	Circuit breaker	Noise filter (EMC corresponding time)	Electro magnetic contactor	Electro magnetic contactor
AC 100V	01	Q1EA04003D	30	0.2	40	NF30 shape 10A Manufactured by Mitsubishi Ltd.	RF1010-DLC Manufactured by RASMI	S-N10 Manufactured by Mitsubishi
		Q1EA04005D	50	0.3				
		Q1EA04010D	100	0.5				
		Q2EA04006D	60	0.3				
		Q2EA04010D	100	0.5				
		Q2EA05005D	50	0.3				
		Q2EA05010D	100	0.5				
		R2EA04003F	30	0.2				
		R2EA04005F	50	0.2				
		R2EA04008F	80	0.4				
		R2EA06010F	100	0.5				
	03	Q1EA06020D	200	0.5				
	Q2EA05020D	200	0.5					
	Q2EA07020D	200	0.5					
	R2EA06020F	200	0.8					

● Recommended surge protector : R·A·V-781BXZ-2A Manufactured by Okaya Electric Industries Co.,Ltd.

● Surge protector/ surge absorber

If there are any possibilities that overvoltage such as lightning surge is applied to servo amplifier, please make sure to install surge protector or surge absorber at the input part of servo amplifier.

Please refer to the following list for recommended products.

Product name	Manufacturer model number	Manufacturer
Surge protector	R·A·V-781BXZ-2A	OKAYA Electric Industries Co., Ltd.
Surge absorber	For AC200V: LT-C32G801WS	SOSHIN ELECTRIC CO., LTD
	For AC100V: LT-C12G801WS	

3.Wiring

[Wire diameter]

■ Recommended wire diameter examples

Input Voltage	Servo motor model number	Motor power wire diameter (U·V·W· \ominus)		servo amplifier combination	Main power supply wire diameter (R·S·T· \ominus)		Control power wire diameter	Regenerative resistor, DC reactor wire diameter	CN1·CN2 Signal wire diameter
		mm ²	AWG No		mm ²	AWG No			
AC200v	Q1AA04003D	0.5	#20	RS1□01	1.25	#16	AWG 16	AWG 16 1.25 mm ²	AWG 24 0.2 mm ²
	Q1AA04005D								
	Q1AA04010D								
	Q1AA06020D	0.75	#18	RS1□03	2.0	#14		AWG 14 2.0 mm ²	
	Q1AA06040D								
	Q1AA07075D	3.5	#12	RS1□05	3.5	#12		AWG 12 3.5 mm ²	
	Q1AA10100D								
	Q1AA10150D								
	Q1AA12100D	3.5	#12	RS1□10	5.5	#10		AWG 10 5.5 mm ²	
	Q1AA10200D								
	Q1AA10250D								
	Q1AA12200D	5.5	#10	RS1□10	5.5	#10		AWG 10 5.5 mm ²	
	Q1AA12300D								
	Q1AA13300D								
	Q1AA13400D	5.5	#10	RS1□15	8.0	#8		AWG 8 8.0 mm ²	
	Q1AA13500D								
	Q1AA18450M								
	Q1AA18750H	14.0	#6	RS1□30	14.0	#6		AWG 6 14.0 mm ²	
	Q2AA04006D	0.5	#20	RS1□01	1.25	#16		AWG 16 1.25 mm ²	
	Q2AA04010D								
	Q2AA05005D								
	Q2AA05010D	0.75	#18	RS1□03	2.0	#14		AWG 14 2.0 mm ²	
	Q2AA05020D								
	Q2AA07020D								
	Q2AA07030D	0.75	#18	RS1□05	3.5	#12		AWG 12 3.5 mm ²	
	Q2AA07040D								
	Q2AA07050D								
	Q2AA08050D	2.0	#14	RS1□10	5.5	#10		AWG 10 5.5 mm ²	
	Q2AA13050H								
	Q2AA08075D								
	Q2AA08100D	0.75	#18	RS1□15	8.0	#8		AWG 8 8.0 mm ²	
	Q2AA10100H								
	Q2AA10150H								
	Q2AA13100H	3.5	#12	RS1□15	8.0	#8		AWG 8 8.0 mm ²	
	Q2AA13150H								
	Q2AA13200H								
	Q2AA18200H	5.5	#10	RS1□30	14.0	#6		AWG 6 14.0 mm ²	
	Q2AA18350H								
	Q2AA18450H								
	Q2AA18550R	8.0	#8	RS1□03	2.0	#14		AWG 14 2.0 mm ²	
	Q2AA22550B								
	Q2AA22700S								
	Q2AA18550H	14.0	#6	RS1□05	2.0	#14		AWG 12 3.5 mm ²	
	Q2AA18750L								
	Q2AA2211KV								
	Q2AA2215KV	0.5	#20	RS1□01	1.25	#16		AWG 16 1.25 mm ²	
	Q4AA1811KB								
	Q4AA1815KB								
R2AA04003F	0.5	#20	RS1□03	2.0	#14	AWG 14 2.0 mm ²			
R2AA04005F									
R2AA04010F									
R2AA06010F	0.75	#19	RS1□05	2.0	#14	AWG 12 3.5 mm ²			
R2AA06020F									
R2AA08020F									
R2AA06040F	0.75	#19	RS1□01	1.25	#16	AWG 16 1.25 mm ²			
R2AA08040F									
R2AA08075F									
R2AAB8100H	0.75	#19	RS1□03	2.0	#14	AWG 14 2.0 mm ²			
R2AA10075F									
R2AA13050D									
R2AA13050H	2.0	#14	RS1□05	2.0	#14	AWG 12 3.5 mm ²			
R2AA13120B									
R2AAB8075F									
R2AAB8100F	0.75	#19	RS1□03	2.0	#14	AWG 14 2.0 mm ²			
R2AA10100F									
R2AA13120D									
R2AA13120L	2.0	#14	RS1□05	2.0	#14	AWG 12 3.5 mm ²			
R2AA13180H									
R2AA13200L									

3.Wiring

[Wire diameter]

Input Voltage	Servo motor model number	Motor power wire diameter (U·V·W· \oplus)		servo amplifier combination	Main power supply wire diameter (R·S·T· \oplus)		Control power wire diameter	Regenerative resistor, DC reactor wire diameter	CN1·CN2 Signal wire diameter
		mm ²	AWG No		mm ²	AWG No			
AC200V	R2AA13200D	8.0	#8	RS1□10	5.5	#10	AWG 16	AWG 10 5.5 mm ²	AWG 24 0.2 mm ²
	R2AA13180D								
	R2AA18350L								
	R2AA22350L								
	R2AA18350D	8.0	#8	RS1□15	8.0	#8		AWG 8 8.0 mm ²	
	R2AA18450H								
	R2AA22500L								
	R2AA18550R								
R2AA18550H	14.0	#6	RS1□30	14.0	#6				
R2AA18750H									
R2AA1811KR									

Input Voltage	Servo motor model number	Motor power wire diameter (U·V·W· \oplus)		servo amplifier combination	Main power supply wire diameter (R·S·T· \oplus)		Control power wire diameter	Regenerative resistor, DC reactor wire diameter	CN1·CN2 Signal wire diameter			
		mm ²	AWG No		mm ²	AWG No						
AC100V	Q1EA04003D	0.5	#20	RS1□01	1.25	#16	AWG 16	AWG 16 1.25 mm ²	AWG 24 0.2 mm ²			
	Q1EA04005D											
	Q1EA04010D											
	Q2EA04006D	0.75	#18					RS1□03		2.0	#14	AWG 14 2.0 mm ²
	Q2EA04010D											
	Q2EA05005D											
	Q2EA05010D	0.75	#18	RS1□03	2.0	#14		AWG 16 1.25 mm ²				
	Q1EA06020D											
	Q2EA05020D											
	Q2EA07020D	0.5	#20	RS1□01	1.25	#16		AWG 14 2.0 mm ²				
	R2EA04003F											
	R2EA04005F											
	R2EA04008F											
R2EA06010F	0.75	#18	RS1□03	2.0	#14	AWG 16 1.25 mm ²						
R2EA06020F												

- The information in this table is based on rated armature current flowing through three bundled lead wires in ambient temperature of 40°C.
- When wires are bundled or put into a wire-duct, take the allowable current reduction ratio into account.
- If ambient temperature is high, service life of the wires becomes shorter due to heat-related deterioration. In this case, use heat-resistant vinyl wires.
- The use of heat-resistant vinyl wires (HIV) is recommended.
- Depending on the servo motor capacity, thinner electric wires than indicated in the above table can be used for the main circuit power input terminal.

■ Connector for servo amplifier

	Name	SANYO DENKI Model No.	Model No. of applicable amplifier	Name	Manufacturer's model No.	Manufacturer	Recommended tightening torque
(1)	CN1	AL-00385594	All	Plug	10150-3000PE	Sumitomo 3M Ltd.	0.196±0.049 N·m (jack-screw)
				Shell kit	10350-52A0-008		
(2)	CN2	AL-00385596	All	Plug	10120-3000PE	Phoenix Contact Ltd.	0.5 to 0.6 N·m
				Shell kit	10320-52A0-008		
(3)	CNA	AL-00329461-01	RS1□01 to RS1□05 (200V input only)	Plug	MSTB2.5/5-STF-5.08	Phoenix Contact Ltd.	0.5 to 0.6 N·m
(4)	CNA	AL-00329461-02	RS1□01 to RS1□03 (100V input only)	Plug	MSTB2.5/4-STF-5.08		
(5)	CNB	AL-Y0000988-01	RS1□01 to RS1□05 (for both 100V·200V)	Plug	IC2.5/6-STF-5.08		
(6)	CNC	AL-00329458-01	RS1□01 to RS1□05 (for both 100V·200V)	Plug	IC2.5/3-STF-5.08		
(7)	PC	AL-00490833-01	All	Communication cable for setup software <i>R-Setup</i>			0.35 N·m

Combination	SANYO DENKI Model No.	Model No. of applicable amplifier
Set of (1)+(2)	AL-00292309	All
Set of (3)+(6)	AL-00416792	RS1□01 to RS1□05 (200V input only)
Set of (1)+(2)+(3)+(6)	AL-00393603	RS1□01 to RS1□05 (200V input only)
Set of (1)+(2)+(4)+(6)	AL-00492384	RS1□01 to RS1□03 (100V input only)

- To have an insulation distance between the main circuit wires and between the main circuit and the signal circuit wires, the use of pole terminals with insulation sleeves is recommended. (If the wire in use is thicker than AWG12, these cannot be used.)

3. Wiring

[How to process CN1/CN2 shields]

■ How to process CN1/CN2 shields.

The drawings below show how to process shields for CN1/CN2 connectors. There are two ways to process shields; clamping and soldering.

● Clamping

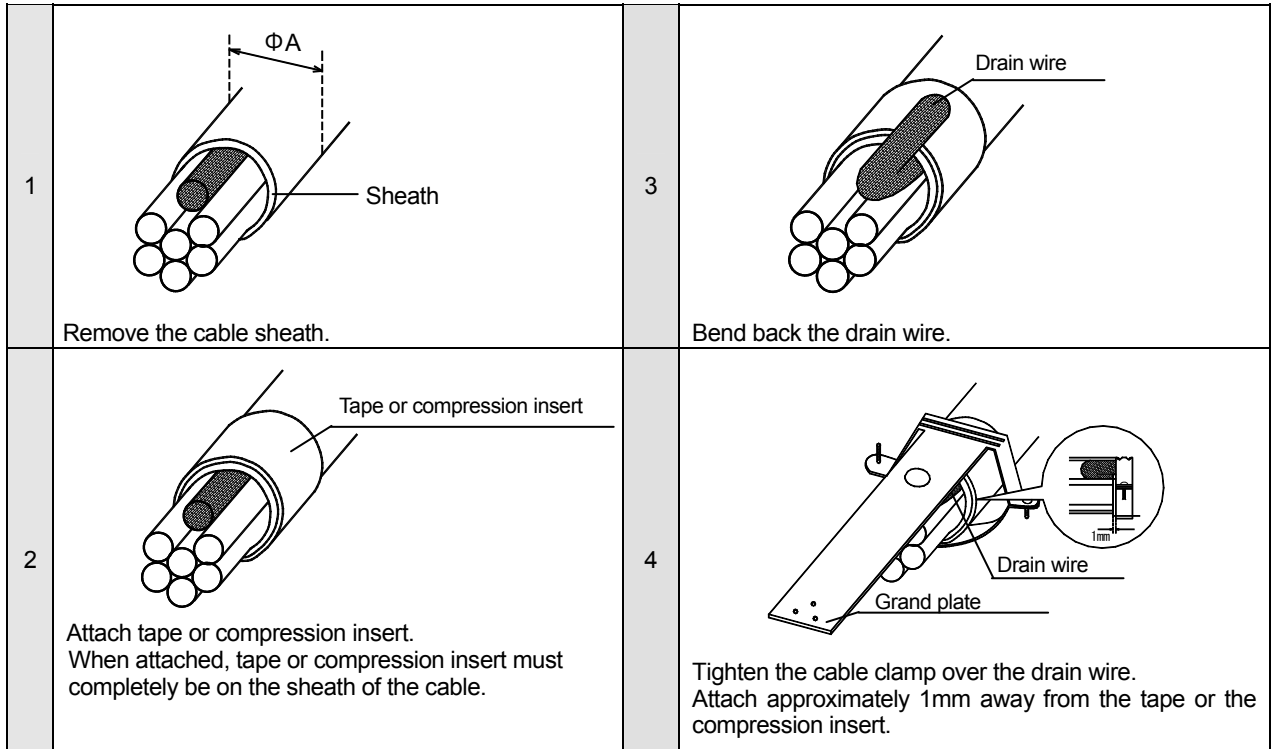

*Compression insert should only be attached before soldering the cable to the connector.

● Soldering (Conditions 1 and 2 are the same as for clamping.)

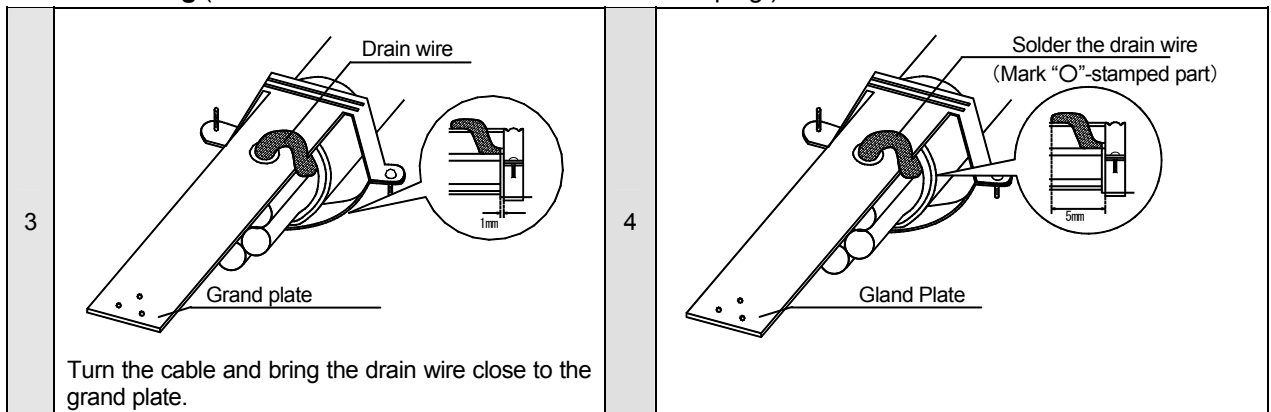

● Applicable ΦA measurements for CN2.

Applicable ΦA measurements are shown below. Compression insert is not required if the ΦA measurements are within these.

Connector NO.	Applicable ΦA-measurement	Connector model number	Manufacturer
CN1	15.0 to 16.5mm	10150-3000PE 10350-52A0-008	Sumitomo 3M Ltd.
CN2	10.5Φ12.0mm	10120-3000PE 10320-52A0-008	Sumitomo 3M Ltd.

No Text on This Page.

[Digital operator]

◆	Names and Functions	4-1
◆	Various Modes	4-2
◆	Changing Modes	4-3
◆	Monitor Mode Operations and Display	4-4
◆	Basic Parameter Mode Operations and Display	4-7
◆	General Parameter Mode Operations and Display	4-9
◆	Auto-adjustment Mode Operations and Display	4-11
◆	Test Run Mode Operations and Display.....	4-12
◆	System Parameter Mode Operations and Display ...	4-14
◆	Alarm Trace/CPU_VER Operations and Display	4-15
◆	Password Setting	4-16

4. Digital Operator

[Names and functions]

- Digital Operator
 - It is possible to change or set the parameters and to confirm the status display, monitor display, test operation and alarm history with the built-in digital operator.
- Digital Operator name and functions

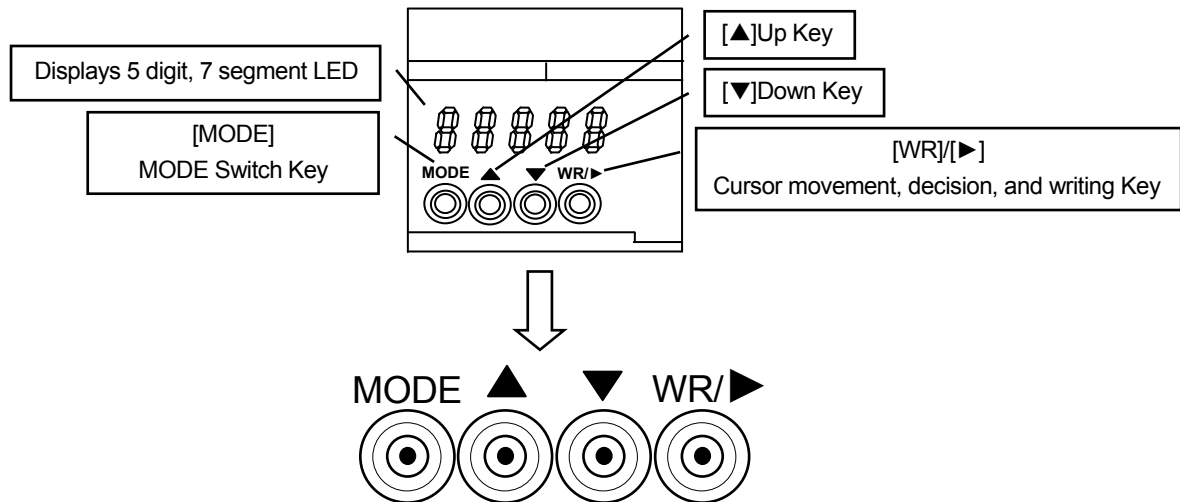

Display	Function	Input time
Digital display	Displays monitor value or parameter setting value in five digits.	---
WR	To input selections and write edited data.	More than 1second
MODE	Changes the Mode.	Less than 1 second
▶	Cursor Key. Changes the cursor position when editing.	Less than 1 second
▲ ▼	Up/Down key. Changes the numeric value.	Less than 1 second

- Displays by cursor key and Up/Down key
 - Up and Down from "1 to 9"
 - Press the Up key, and the blinking numeric value of LED display will increase. Press the Down key, and the numeric value decreases.
 - Up from "9"
 - Press the Up key, and the numeric value at cursor position increases and shifts to the left digit.
 - Down from "0"
 - Press the Down key, and the numeric value at cursor position decreases and the numeric values in the left of cursor position shift to the right. If there is no numeric value in the left of cursor position, all the left digits from cursor position show 9 with a right shift.
 - Up/Down of "Symbol"
 - When the display is "0," "+ data" will be displayed by pressing the Up key and "- data" by the Down key, regardless of the cursor position. When the display is other than "0", there will be a left shift or right shift as usual. (Display of "0"="0000", "000", "00")

The [+data] has no light on the furthest left digit, and the [-data] has a symbol of [-] on the furthest left digit.

4.Digital Operator

[Names and functions]

■ Various modes

- It is possible to display the status, to change or set the parameters, to automatically set the notch filter, and to confirm test operation, alarm history and monitor display with the built-in digital operator.

Mode	Contents																						
Status Display	Displays the establishment of control or main power supply, Servo ON, over-travel, warning and alarm status. [Page 4-3]																						
[bA] Basic parameter	Parameters necessary for test operations by JOG and auto-tuning. Can be set at generic parameter mode. [Page 4-7]																						
[Gr] General parameter	<p>Settings can be made suitable for machines and equipment. Parameters for adjusting servo gain can be changed. Classified into 10 groups according to the functions. [Page 4-9]</p> <table border="1"> <thead> <tr> <th>Group</th> <th>Description of Group</th> </tr> </thead> <tbody> <tr> <td>Group0</td> <td>Settings of tuning mode.</td> </tr> <tr> <td>Group1</td> <td>Settings of basic control parameters.</td> </tr> <tr> <td>Group2</td> <td>Settings of damping control/notch filter/disturbance observer</td> </tr> <tr> <td>Group3</td> <td>Settings of gain switching control/damping frequency switching</td> </tr> <tr> <td>Group4</td> <td>To set high setting control.</td> </tr> <tr> <td>Group8</td> <td>Settings related to system control</td> </tr> <tr> <td>Group9</td> <td>Settings related to general purpose input signals/function condition setting</td> </tr> <tr> <td>GroupA</td> <td>Settings related to generic output signals/monitor output signals/set-up software</td> </tr> <tr> <td>GroupB</td> <td>Settings related to system sequence/warnings or alarms.</td> </tr> <tr> <td>GroupC</td> <td>Settings related to servo motor encoder.</td> </tr> </tbody> </table>	Group	Description of Group	Group0	Settings of tuning mode.	Group1	Settings of basic control parameters.	Group2	Settings of damping control/notch filter/disturbance observer	Group3	Settings of gain switching control/damping frequency switching	Group4	To set high setting control.	Group8	Settings related to system control	Group9	Settings related to general purpose input signals/function condition setting	GroupA	Settings related to generic output signals/monitor output signals/set-up software	GroupB	Settings related to system sequence/warnings or alarms.	GroupC	Settings related to servo motor encoder.
Group	Description of Group																						
Group0	Settings of tuning mode.																						
Group1	Settings of basic control parameters.																						
Group2	Settings of damping control/notch filter/disturbance observer																						
Group3	Settings of gain switching control/damping frequency switching																						
Group4	To set high setting control.																						
Group8	Settings related to system control																						
Group9	Settings related to general purpose input signals/function condition setting																						
GroupA	Settings related to generic output signals/monitor output signals/set-up software																						
GroupB	Settings related to system sequence/warnings or alarms.																						
GroupC	Settings related to servo motor encoder.																						
[Au] Automatic adjustment	Enables Automatic Adjustment for Torque Command; Notch Filter A, Vibration Suppressor frequency and Offset of Analog Velocity/Torque/Torque Addition Command. [Page 4-11]																						
[Ad] Test operation	Enables JOG operation, Alarm Reset, Automatic Tuning Result writing, Encoder Clear and Alarm History Clear. [Page 4-12]																						
[Sy] System Parameter	Sets the parameters related to servo amplifier - servo motor specifications. [Page 4-14]																						
[AL] Alarm history, software version	Displays the latest 7 alarm events, as well as the servo amplifier CPU software version. [Page 4-15]																						
[ob] Monitor	Displays the servo amplifier status such as Velocity, Velocity Command, Torque, Torque command, Position Deviation and Servo Adjustment Gain when using auto-tuning. [Page 4-5]																						

4. Digital Operator

[Changing modes]

- How to change the modes
 - Change the modes in the order as shown below by pressing the **MODE** key for changing the settings or for test operation.

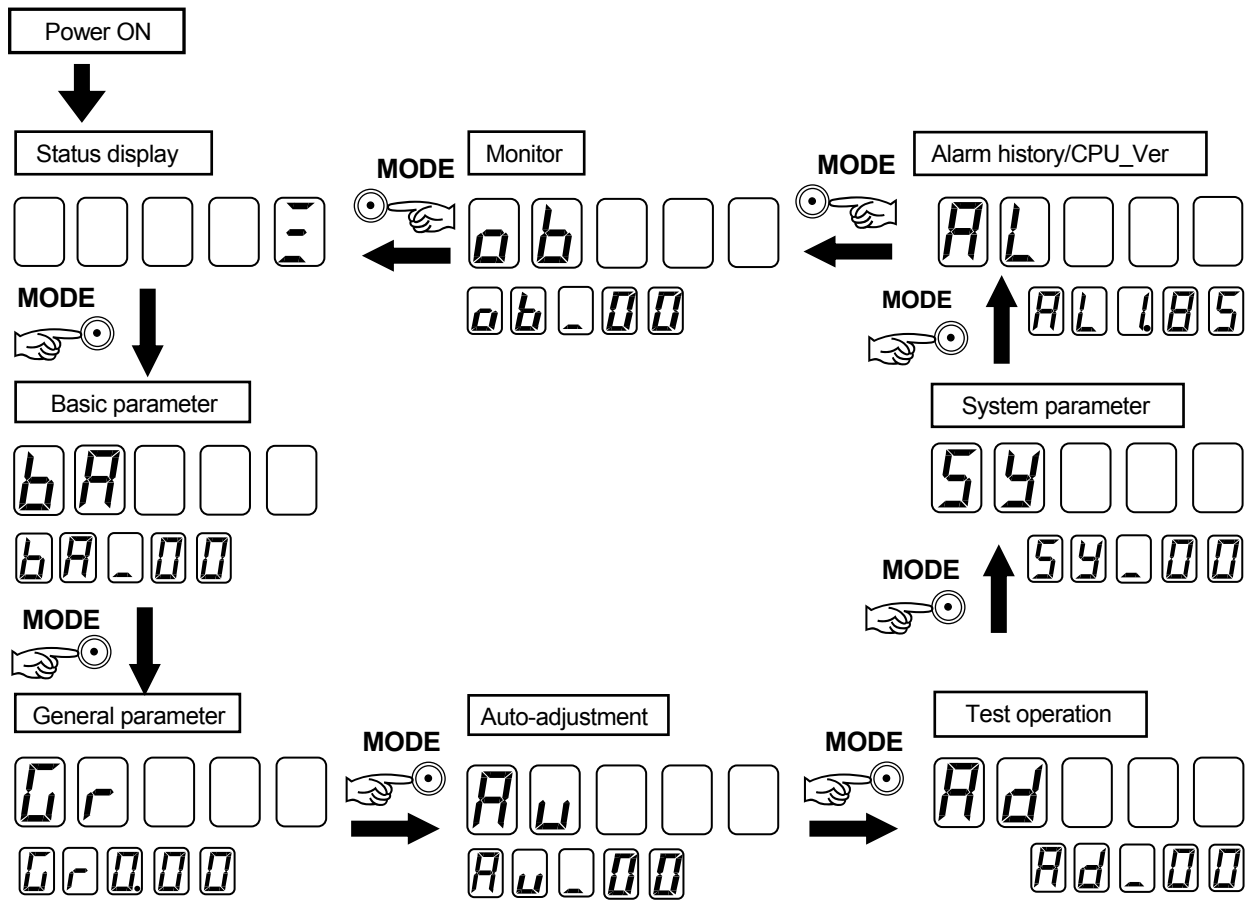

- Status display mode**
 - In the status display mode, various conditions are displayed according to the status of servo amplifier as shown in the following table.

Servo amplifier status	Indication
Control power supply established Control power supply (r,t) is established and amplifier (RDY) is ON.	00000-
Main power supply being established Main power supply (R,S,T) is ON or is established, but Operation Preparation Completion signal is OFF.	00000-
Main power supply established Main power supply (R,S,T) is established and Operation Preparation Completion signal is ON.	00000E
Servo is ON. Rotates after drawing the character "8"	000008
Over-travel status at normal rotation Forward rotation is in 'Over-Travel' status in position and speed control type.	000007
Over-travel status at reverse rotation Reverse rotation is in 'Over-Travel' status in position and speed control type.	00000F

4. Digital Operator [Monitor mode operations and display]

Overload warning status If operation is kept on, alarm may be issued.	
Regenerative overload warning status If operation is kept on, alarm may be issued.	
Battery warning status Replace the battery.	
Alarm display When an alarm rings, take corrective actions as instructed in "Chapter 8, Maintenance".	



- In addition to the above, warning functions include "excessive deviation warning" and "amplifier temperature warning", which can be confirmed at monitor mode.
- There is a possibility that an overload warning will be detected when the control power is supplied, if the overload warning level is set below 75% (generic parameter GroupB Page22), because a rated load of 75% (hot start) has been assumed for the overload detection process when control power is supplied.

■ Description of monitor mode

- Various contents can be monitored as shown below at each page of monitor mode.

Page	Name	Contents	Unit	Display
00	Servo Amplifier Status	Main circuit power supply status. Operation preparation status. Servo ON status: Servo ON Displays the status of servo amplifier, as mentioned above.	---	Code
01	Warning Status 1	Displays warning status.	---	Bit
02	Warning Status 2	Displays warning status.	---	
03	General purpose input CONT8 to 1 monitor	Displays the status of the general input terminal.	---	
04	General purpose output OUT8 to 1 monitor	Displays status of general output terminal.	---	
05	Velocity Monitor	Displays number of motor rotations.	min ⁻¹	Decimal
06	Velocity Command Monitor	Displays velocity command value.	min ⁻¹	
07	Torque Monitor	Displays output torque of motor.	%	
08	Torque Command Monitor	Displays torque command value.	%	
09	Position Deviation Monitor	Displays position deviation value.	Pulse	32 bit data Hexadecimal
0A	Actual Position Monitor (Motor Encoder)	Displays the current position assumed that the position at the time of control power turn-ON is origin. This is a free run counter, therefore, if the current position exceeds the displayed range, the maximum value of reverse polarity will be displayed.	Pulse	
0B	External Actual Position Monitor (External Encoder)			
0C	Command Position Monitor			
0D	Analog Velocity Command / Analog Torque Command Input Voltage	Displays entered command voltage.	mV	Decimal
0E	Position Command Pulse Input Frequency Monitor	Displays entered command pulse frequency.	k Pulse /s	
0F	U-Phase Electric Angle Monitor	Always displays U-phase electric angle, excluding encoder errors.	deg	
10	Absolute Encoder PS Data (High)	Displays position data PS of absolute encoder.	x2 ³² P	32 bit data Hexadecimal
11	Absolute Encoder PS Data (Low)	Displays position data PS of absolute encoder.	Pulse	
12	Regenerative Resistor Operation Percentage	Displays run rate of regenerative resistance.	%	Decimal
13	Motor Operating Rate Monitor	Displays the accurate value, however, it may sometimes take several hours for the value to become stable depending on the operation pattern..	%	
14	Predicted Motor Operating Rate Monitor	Displays estimated value of the servo motor usage ratio. Estimated from brief operation. In an application where the same operation pattern repeats in a short time, the usage ratio can be confirmed soon.	%	

4. Digital Operator [Monitor mode operations and display]

15	Load Inertia Ratio Monitor	Values can be confirmed when gain switching and auto-tuning functions are used.	%	Decimal
16	Position Loop Proportional Gain Monitor		1/s	
17	Position Loop Integral Time Constant Monitor	Values can be confirmed when gain switching function is used.	ms	
18	Velocity Loop Proportional Gain Monitor		Hz	
19	Velocity Loop Integral Time Constant Monitor	Values can be confirmed when gain switching and auto-tuning functions are used.	ms	
1A	Torque command filter monitor		Hz	
1B	Incremental Encoder Signal Monitor	Displays CN2 incremental signals.	----	Bit
1C	Load Torque Monitor (Estimate Value)	Displays load torque.	%	Decimal
1D	Power Monitor	Displays the main circuit DC voltage.	V	
1E	Servo Amplifier Operation Time	Counted during control power is being turned ON. The time is displayed value×2 (hours).	×2 hour	

■ How to operate the monitor mode

- See the followings for how to operate the monitor mode and how to interpret the displayed data.

Step	Key	Description	Display																					
1	MODE	Press the MODE key to display monitor mode.	ob																					
2	----	Displays the page automatically. After the power supply is turned ON, "Page 00" is displayed. Then, the previously displayed page is displayed.	ob_00																					
3	▶	Pressing the cursor key makes the blinking LED move. Move the blinking LED to the desired page to be changed.	ob_00																					
4	▲ ▼	Pressing the UP key increases the blinking numeric value and the Down key decreases.	ob_01																					
5	WR	On the page to be monitored, press the WR key to display the data.	Refer to display																					
6	MODE	Pressing the MODE key returns to step 2.	ob_00																					
7	MODE	Pressing the MODE key again returns to status display.																						
	When the pages not allocated are set, the display is as shown in the right.		no.dAt																					
Page	Name	Display: code																						
00	Servo Amplifier Status	<table border="1"> <thead> <tr> <th></th> <th>Display</th> <th></th> <th>Display</th> </tr> </thead> <tbody> <tr> <td>Control power established</td> <td>00000</td> <td>Main power established</td> <td>00004</td> </tr> <tr> <td>Main power being established</td> <td>00002</td> <td>Servo ON status</td> <td>00008</td> </tr> </tbody> </table>		Display		Display	Control power established	00000	Main power established	00004	Main power being established	00002	Servo ON status	00008										
	Display		Display																					
Control power established	00000	Main power established	00004																					
Main power being established	00002	Servo ON status	00008																					
Page	Name	Display: bit																						
01	Warning Status 1	<table border="1"> <thead> <tr> <th></th> <th>Display</th> <th></th> </tr> </thead> <tbody> <tr> <td>Warning status1</td> <td>LED 1 beginning from right 4 3 2 1 ← [LED] </td> <td>↑ With warning</td> </tr> <tr> <td>Warning status2</td> <td>7 6 5 4 3 2 1 0 bit</td> <td>↓ No warning</td> </tr> </tbody> </table>			Display		Warning status1	LED 1 beginning from right 4 3 2 1 ← [LED] 	↑ With warning	Warning status2	7 6 5 4 3 2 1 0 bit	↓ No warning												
	Display																							
Warning status1	LED 1 beginning from right 4 3 2 1 ← [LED] 			↑ With warning																				
Warning status2	7 6 5 4 3 2 1 0 bit	↓ No warning																						
02	Warning Status 2																							
03	General Purpose Input CONT8 to CONT1 Monitor																							
04	General Purpose Output CONT8 to CONT1 Monitor	<table border="1"> <thead> <tr> <th></th> <th>Display</th> <th></th> </tr> </thead> <tbody> <tr> <td>General purpose input</td> <td>LED 1 beginning from right 4 3 2 1 ← [LED] </td> <td>↑ Input photo coupler ON</td> </tr> <tr> <td>General purpose output</td> <td>7 6 5 4 3 2 1 0 bit</td> <td>Output transistor ON</td> </tr> <tr> <td>Incremental signal</td> <td></td> <td>Signal level H</td> </tr> <tr> <td></td> <td></td> <td>↓ Input photo coupler OFF</td> </tr> <tr> <td></td> <td></td> <td>Output transistor OFF</td> </tr> <tr> <td></td> <td></td> <td>Signal level L</td> </tr> </tbody> </table>			Display		General purpose input	LED 1 beginning from right 4 3 2 1 ← [LED] 	↑ Input photo coupler ON	General purpose output	7 6 5 4 3 2 1 0 bit	Output transistor ON	Incremental signal		Signal level H			↓ Input photo coupler OFF			Output transistor OFF			Signal level L
	Display																							
General purpose input	LED 1 beginning from right 4 3 2 1 ← [LED] 	↑ Input photo coupler ON																						
General purpose output	7 6 5 4 3 2 1 0 bit	Output transistor ON																						
Incremental signal		Signal level H																						
		↓ Input photo coupler OFF																						
		Output transistor OFF																						
		Signal level L																						
1B	Incremental Encoder Signal Monitor																							

4. Digital Operator [Monitor mode operations and display]

Name	Corresponding bits							
	7	6	5	4	3	2	1	0
Warning Status1	Excessive deviation warning	---	Speed limit operation running	Torque limit operation running	Regeneration overload warning	Overload warning	---	Amplifier temperature warning
Warning Status 2	---	Low battery warning	---	---	Reverse over-travel	Forward over-travel	---	Main circuit power being charged
General Purpose Input CONT8 to CONT1 Monitor	CONT8	CONT7	CONT6	CONT5	CONT4	CONT3	CONT2	CONT1
General Purpose Output OUT8 to OUT1 Monitor	OUT8	OUT7	OUT6	OUT5	OUT4	OUT3	OUT2	OUT1
Incremental signal	---	External encoder Z phase signal	External encoder B phase signal	External encoder A phase signal	---	Servo motor encoder Z phase signal	Servo motor encoder B phase signal	Servo motor encoder A phase signal

Page	Name	Displayed form: Decimal																																									
05	Velocity Monitor	<table border="1"> <tr> <td>Display of "-" data</td> <td>Display of "+" data</td> <td rowspan="2"> The "+" data is displayed without the mark "+" on LED.</td> </tr> <tr> <td><u>-5000</u></td> <td><u>05000</u></td> </tr> <tr> <td><u>-0100</u></td> <td><u>00100</u></td> <td></td> </tr> </table>	Display of "-" data	Display of "+" data	The "+" data is displayed without the mark "+" on LED.	<u>-5000</u>	<u>05000</u>	<u>-0100</u>	<u>00100</u>																																		
Display of "-" data	Display of "+" data		The "+" data is displayed without the mark "+" on LED.																																								
<u>-5000</u>	<u>05000</u>																																										
<u>-0100</u>	<u>00100</u>																																										
06	Velocity Command Monitor																																										
07	Torque Monitor																																										
08	Torque Command Monitor																																										
0E	Position Command Pulse Input Frequency Monitor																																										
0F	U-Phase Electric Angle Monitor	<table border="1"> <thead> <tr> <th>Name</th> <th>Display range</th> <th>Unit</th> </tr> </thead> <tbody> <tr> <td>Velocity Monitor / Velocity Command Monitor</td> <td>-9999 to 9999</td> <td>min⁻¹</td> </tr> <tr> <td>Torque Monitor / Torque Command Monitor</td> <td>-499 to 499</td> <td>%</td> </tr> <tr> <td>Position Command Pulse Input Frequency Monitor</td> <td>-6000 to 6000</td> <td>k Pulse/s</td> </tr> <tr> <td>U-Phase Electric Angle Monitor</td> <td>0 to 359</td> <td>deg</td> </tr> <tr> <td>Motor Operating Rate Monitor/ Predicted Motor Operating Rate Monitor</td> <td>0 to 499</td> <td>%</td> </tr> <tr> <td>Load Inertia Ratio Monitor</td> <td>0 to 15000</td> <td>%</td> </tr> <tr> <td>Position Loop Proportional Gain Monitor</td> <td>1 to 3000</td> <td>1/s</td> </tr> <tr> <td>Velocity Loop Proportional Gain Monitor</td> <td>1 to 2000</td> <td>Hz</td> </tr> <tr> <td>Torque Command Filter Monitor</td> <td>1 to 2000</td> <td>Hz</td> </tr> <tr> <td>Load Torque Monitor (Estimate Value)</td> <td>-499 to 499</td> <td>%</td> </tr> <tr> <td>1D</td> <td>Power Monitor</td> <td>0 to 1000</td> <td>V</td> </tr> <tr> <td>1E</td> <td>Servo Amplifier Operation Time</td> <td>---</td> <td>×2 hour</td> </tr> </tbody> </table>	Name	Display range	Unit	Velocity Monitor / Velocity Command Monitor	-9999 to 9999	min ⁻¹	Torque Monitor / Torque Command Monitor	-499 to 499	%	Position Command Pulse Input Frequency Monitor	-6000 to 6000	k Pulse/s	U-Phase Electric Angle Monitor	0 to 359	deg	Motor Operating Rate Monitor/ Predicted Motor Operating Rate Monitor	0 to 499	%	Load Inertia Ratio Monitor	0 to 15000	%	Position Loop Proportional Gain Monitor	1 to 3000	1/s	Velocity Loop Proportional Gain Monitor	1 to 2000	Hz	Torque Command Filter Monitor	1 to 2000	Hz	Load Torque Monitor (Estimate Value)	-499 to 499	%	1D	Power Monitor	0 to 1000	V	1E	Servo Amplifier Operation Time	---	×2 hour
Name	Display range		Unit																																								
Velocity Monitor / Velocity Command Monitor	-9999 to 9999		min ⁻¹																																								
Torque Monitor / Torque Command Monitor	-499 to 499		%																																								
Position Command Pulse Input Frequency Monitor	-6000 to 6000		k Pulse/s																																								
U-Phase Electric Angle Monitor	0 to 359		deg																																								
Motor Operating Rate Monitor/ Predicted Motor Operating Rate Monitor	0 to 499		%																																								
Load Inertia Ratio Monitor	0 to 15000		%																																								
Position Loop Proportional Gain Monitor	1 to 3000		1/s																																								
Velocity Loop Proportional Gain Monitor	1 to 2000		Hz																																								
Torque Command Filter Monitor	1 to 2000		Hz																																								
Load Torque Monitor (Estimate Value)	-499 to 499	%																																									
1D	Power Monitor	0 to 1000	V																																								
1E	Servo Amplifier Operation Time	---	×2 hour																																								
13	Motor Operating Rate Monitor																																										
14	Predicted Motor Operating Rate Monitor																																										
15	Load Inertia Ratio Monitor																																										
16	Position Loop Proportional Gain Monitor																																										
18	Velocity Loop Proportional Gain Monitor																																										
1A	Torque Command Filter Monitor																																										
1C	Load Torque Monitor (Estimate Value)																																										
Page	Name	Display form: 32 bit data displayed in hexadecimal																																									
09	Position Deviation Monitor	<table border="1"> <tr> <td>Bit data display "31"- "16"</td> <td>Bit data display "15"- "0"</td> </tr> <tr> <td><u>H.0000</u></td> <td><u>L.0000</u></td> </tr> </table>	Bit data display "31"- "16"	Bit data display "15"- "0"	<u>H.0000</u>	<u>L.0000</u>																																					
Bit data display "31"- "16"	Bit data display "15"- "0"																																										
<u>H.0000</u>	<u>L.0000</u>																																										
0A	Actual Position Monitor (Motor Encoder)																																										
0B	External Actual Position Monitor (External Encoder)																																										
0C	Command Position Monitor	<table border="1"> <thead> <tr> <th>Name</th> <th>Display range</th> <th>Unit</th> </tr> </thead> <tbody> <tr> <td>Position Deviation Monitor/ Actual Position Monitor/ Command Position Monitor</td> <td>8000-0000 to 7FFF-FFFF</td> <td>Pulse</td> </tr> <tr> <td>Absolute Encoder PS Data High/Low</td> <td>0000-0000 to FFFF-FFFF</td> <td>Pulse</td> </tr> </tbody> </table> Pressing the ▲ key displays "H" data, and ▼ key displays "L" data.	Name	Display range	Unit	Position Deviation Monitor/ Actual Position Monitor/ Command Position Monitor	8000-0000 to 7FFF-FFFF	Pulse	Absolute Encoder PS Data High/Low	0000-0000 to FFFF-FFFF	Pulse																																
Name	Display range		Unit																																								
Position Deviation Monitor/ Actual Position Monitor/ Command Position Monitor	8000-0000 to 7FFF-FFFF	Pulse																																									
Absolute Encoder PS Data High/Low	0000-0000 to FFFF-FFFF	Pulse																																									
10	Absolute Encoder PS Data (High)																																										
11	Absolute Encoder PS Data (Low)																																										
Page	Name	Display form: Decimal point																																									
0D	Analog Velocity Command/ Torque Command Input Voltage	<table border="1"> <tr> <td>Decimal point "-" data display</td> <td>Decimal point "+" data display</td> <td rowspan="2"> The "+" data is displayed without the mark "+" on LED .</td> </tr> <tr> <td><u>-12.00</u></td> <td><u>012.00</u></td> </tr> </table>	Decimal point "-" data display	Decimal point "+" data display	The "+" data is displayed without the mark "+" on LED .	<u>-12.00</u>	<u>012.00</u>																																				
Decimal point "-" data display	Decimal point "+" data display		The "+" data is displayed without the mark "+" on LED .																																								
<u>-12.00</u>	<u>012.00</u>																																										
12	Regenerative Resistor Operation Percentage																																										
17	Position Loop Integral Time Constant Monitor	<table border="1"> <tr> <td>Data display of "one decimal place"</td> <td>Data display of "two decimal place"</td> </tr> <tr> <td><u>0000.1</u></td> <td><u>0000.01</u></td> </tr> </table>	Data display of "one decimal place"	Data display of "two decimal place"	<u>0000.1</u>	<u>0000.01</u>																																					
Data display of "one decimal place"	Data display of "two decimal place"																																										
<u>0000.1</u>	<u>0000.01</u>																																										
19	Velocity Loop Integral Time Constant Monitor	<table border="1"> <thead> <tr> <th>Name</th> <th>Display range</th> <th>Unit</th> </tr> </thead> <tbody> <tr> <td>Regenerative Resistor Operation Percentage</td> <td>0.00 to 99.99</td> <td>%</td> </tr> <tr> <td>Position Loop Integral Time Constant Monitor</td> <td>0.5 to 1000.0</td> <td>msec</td> </tr> <tr> <td>Velocity Loop Integral Time Constant Monitor</td> <td>0.5 to 1000.0</td> <td>msec</td> </tr> </tbody> </table>	Name	Display range	Unit	Regenerative Resistor Operation Percentage	0.00 to 99.99	%	Position Loop Integral Time Constant Monitor	0.5 to 1000.0	msec	Velocity Loop Integral Time Constant Monitor	0.5 to 1000.0	msec																													
Name	Display range	Unit																																									
Regenerative Resistor Operation Percentage	0.00 to 99.99	%																																									
Position Loop Integral Time Constant Monitor	0.5 to 1000.0	msec																																									
Velocity Loop Integral Time Constant Monitor	0.5 to 1000.0	msec																																									

4. Digital Operator [Basic parameter mode operations and display]

■ Description of basic parameter mode







- The following parameters can be set and changed at each page of the basic parameter mode. These parameters are necessary when test run by JOG operation and real time auto-tuning are used.

MODE	Page	Name	Contents	Group and Page
Ba	00	Setup Software, Communication Axis Number	Selects the axis number when communicating with PC.	GroupA 20
	01	Setup Software, Communication Baud Rate	Selection of Baud rate when communicating with PC.	GroupA 21
	02	Tuning Mode	Tuning mode selection	Group0 00
	03	Automatic Tuning Response	Response when auto-tuning is used.	Group0 02
	04	Position Command Filter	Sets the low pass filter of position command pulse	Group1 01
	05	Electric Gear Ratio 1	Sets the electric gear for position command pulse	Group8 15
	06	In-Position Window	Range setting for positioning complete signal output	Group8 41
	07	Forward over-travel	Condition selection to enable forward over-travel function	Group9 00
	08	Positive Over-Travel Function	Condition selection to enable reverse over-travel function	Group9 01
	09	Alarm Reset Function	Condition selection to enable alarm resetting function	Group9 02
	0A	Absolute Encoder Clear Function	Condition selection to enable encoder clearing function	Group9 03
	0B	Deviation Clear Function	Condition selection to enable deviation clearing function	Group9 04
	0C	SERVO-ON Function	Condition selection to enable servo ON function	Group9 05
	0D	Torque Limit, Input Selection	Condition selection to enable torque limiting function	Group9 32
	0E	JOG Velocity Command	Sets the speed command at JOG operation.	GroupB 00
	0F	Encoder Output Pulse, Divide Ratio	Setting of encoder pulse dividing output	GroupC 05
	10	Analog Velocity Command Offset	Manual offset adjustment of analog speed command	-- --

 Refer to "Chapter 5, Parameter" for the details of parameters.

■ How to set the basic parameter mode

- See the followings for how to operate and set the basic parameter mode.

Step	Key	Description	Display
1	MODE	Press the MODE key to display basic mode.	bA
2	—	Displays the page automatically. After the power supply is turned ON, "Page 00" is displayed. Then, the previously displayed page is displayed.	bA_00
3		Pressing the cursor key makes the blinking LED move. Move the blinking LED to the page to be changed.	bA_00
4	 	Pressing the UP key increases the blinking value and the Down key decreases.	bA_03
5	WR	On the page to be changed, press the WR key to display the data.	Refer to display
6		Pressing the cursor key makes the blinking LED move. Move the blinking LED to the desired value to be changed.	0000d
7	 	Pressing the UP key increases the blinking value and the Down key decreases.	00000
8	WR	Press the WR key, and the display will blink 3 times to write. If writing is impossible, the numeric value is out of setting range. Check the setting value again.	00000
9	MODE	Pressing the MODE key returns to step 2.	bA_00
10	MODE	Pressing the MODE key again returns to status display.	
	When the pages not allocated are set, the display is as shown in the right.		no.dAt

 For setting the dividing ratio of dividing output, different procedure is taken at step 5. Refer to page 4-8 for how to set fractions.

4.Digital Operator

[Basic parameter mode operations and display]

Page	Name	Display form: decimal																																																									
00	Setup Software, Communication Axis Number	<table border="1"> <tr><td>Data indication</td></tr> <tr><td>05000</td></tr> </table>				Data indication	05000																																																				
Data indication																																																											
05000																																																											
01	Setup Software, Communication Baud Rate																																																										
02	Tuning Mode																																																										
03	Automatic Tuning Response	<table border="1"> <thead> <tr> <th>Name</th> <th>Standard setting</th> <th>Unit</th> <th>Setting range</th> </tr> </thead> <tbody> <tr> <td>Communication axis number of Setup software</td> <td>01</td> <td>---</td> <td>01 to 0F</td> </tr> <tr> <td>communication baud rate of Setup software</td> <td>05</td> <td>---</td> <td>00 to 05</td> </tr> <tr> <td>Tuning mode</td> <td>00</td> <td>---</td> <td>00 to 02</td> </tr> <tr> <td>Auto-tuning response</td> <td>5</td> <td>---</td> <td>1 to 30</td> </tr> <tr> <td>Positioning complete range</td> <td>100</td> <td>Pulse</td> <td>1 to 65535</td> </tr> <tr> <td>Forward over-travel function</td> <td>0D</td> <td>---</td> <td rowspan="7">00 to 27</td> </tr> <tr> <td>Reverse over-travel function</td> <td>0B</td> <td>---</td> </tr> <tr> <td>Alarm resetting function</td> <td>10</td> <td>---</td> </tr> <tr> <td>Absolute encoder clearing function</td> <td>06</td> <td>---</td> </tr> <tr> <td>Deviation clearing function</td> <td>08</td> <td>---</td> </tr> <tr> <td>Servo ON function</td> <td>02</td> <td>---</td> </tr> <tr> <td>Torque limiting function</td> <td>0E</td> <td>---</td> </tr> <tr> <td>JOG-speed command</td> <td>50</td> <td>min⁻¹</td> <td>0~32767</td> </tr> <tr> <td>Dividing ratio of encoder pulse dividing output</td> <td>1/1</td> <td>---</td> <td>1/8192 to 1/1</td> </tr> </tbody> </table>				Name	Standard setting	Unit	Setting range	Communication axis number of Setup software	01	---	01 to 0F	communication baud rate of Setup software	05	---	00 to 05	Tuning mode	00	---	00 to 02	Auto-tuning response	5	---	1 to 30	Positioning complete range	100	Pulse	1 to 65535	Forward over-travel function	0D	---	00 to 27	Reverse over-travel function	0B	---	Alarm resetting function	10	---	Absolute encoder clearing function	06	---	Deviation clearing function	08	---	Servo ON function	02	---	Torque limiting function	0E	---	JOG-speed command	50	min ⁻¹	0~32767	Dividing ratio of encoder pulse dividing output	1/1	---	1/8192 to 1/1
Name	Standard setting					Unit	Setting range																																																				
Communication axis number of Setup software	01					---	01 to 0F																																																				
communication baud rate of Setup software	05					---	00 to 05																																																				
Tuning mode	00					---	00 to 02																																																				
Auto-tuning response	5					---	1 to 30																																																				
Positioning complete range	100					Pulse	1 to 65535																																																				
Forward over-travel function	0D					---	00 to 27																																																				
Reverse over-travel function	0B					---																																																					
Alarm resetting function	10					---																																																					
Absolute encoder clearing function	06					---																																																					
Deviation clearing function	08					---																																																					
Servo ON function	02					---																																																					
Torque limiting function	0E					---																																																					
JOG-speed command	50	min ⁻¹	0~32767																																																								
Dividing ratio of encoder pulse dividing output	1/1	---	1/8192 to 1/1																																																								
06	In-Position Window																																																										
07	Positive Over-Travel Function																																																										
08	Negative Over-Travel Function																																																										
09	Alarm Reset Function																																																										
0A	Absolute Encoder Clear Function																																																										
0B	Deviation Clear Function																																																										
0C	SERVO-ON Function																																																										
0D	Torque Limit, Input Selection																																																										
0E	JOG Velocity Command																																																										
Page	Name	Display form: decimal point																																																									
04	Position Command Filter	<table border="1"> <thead> <tr> <th>Name</th> <th>Standard setting</th> <th>Unit</th> <th>Setting range</th> </tr> </thead> <tbody> <tr> <td>position command filter</td> <td>0.0</td> <td>ms</td> <td>0.0 to 2000.0</td> </tr> </tbody> </table>				Name	Standard setting	Unit	Setting range	position command filter	0.0	ms	0.0 to 2000.0																																														
Name	Standard setting					Unit	Setting range																																																				
position command filter	0.0	ms	0.0 to 2000.0																																																								
	Data display of "decimal point1" 0000.1																																																										
Page	Name	Display form: fraction																																																									
10	Analog Velocity Command Offset	<table border="1"> <thead> <tr> <th>Standard setting value unit</th> <th>Unit</th> <th>Setting range</th> </tr> </thead> <tbody> <tr> <td>0</td> <td>---</td> <td>-9999 to +9999</td> </tr> </tbody> </table>				Standard setting value unit	Unit	Setting range	0	---	-9999 to +9999																																																
Standard setting value unit	Unit					Setting range																																																					
0	---	-9999 to +9999																																																									
	Display of "-"data Display of "+"data -01000 01000																																																										
Page	Name	Display form : fraction																																																									
05 0F	Electric Gear Ratio	<table border="1"> <thead> <tr> <th>Name</th> <th>Standard setting value</th> <th>Unit</th> <th>Setting range</th> </tr> </thead> <tbody> <tr> <td>Electric Gear Ratio</td> <td>1/1</td> <td></td> <td>1/32767 to 32767/1</td> </tr> <tr> <td>Encoder Output Pulse, Divide Ratio</td> <td>1/1</td> <td>---</td> <td>1/8192 to 1/1</td> </tr> </tbody> </table>				Name	Standard setting value	Unit	Setting range	Electric Gear Ratio	1/1		1/32767 to 32767/1	Encoder Output Pulse, Divide Ratio	1/1	---	1/8192 to 1/1																																										
	Name					Standard setting value	Unit	Setting range																																																			
	Electric Gear Ratio					1/1		1/32767 to 32767/1																																																			
Encoder Output Pulse, Divide Ratio	1/1	---	1/8192 to 1/1																																																								
	Encoder Output Pulse, Divide Ratio																																																										
	Numerator data display denominator data display 0.0001 00001																																																										
	Denominator is displayed with a dot at its right.																																																										
How to set fractional data. [different from step 5 of the basic mode setting procedure]																																																											
The following example is when the data needs to be changed to 2/64 from the set value of 1/1.																																																											
5	WR	Press the WR key on the page to be changed, and the numerator data will be displayed.	0 1																																																								
		Pressing the cursor key makes the blinking LED move. Move the blinking LED to the page to be changed.	0 1																																																								
		Pressing the UP key increases the blinking numeric value and the Down key decreases.	0 2																																																								
	WR	Press the WR key, and the display will blink 3 times to write. If writing is impossible, the numeric value is out of setting range. Check the setting value again.	0 2																																																								
		Press the Down key, and denominator data will be displayed. Denominator is displayed with a dot at its right.	001.																																																								
		Pressing the cursor key makes the blinking LED move. Move the blinking to the numeric value to be changed.	001.																																																								
		Pressing the UP key increases the blinking numeric value and the Down key decreases.	064.																																																								
	WR	Press the WR key, and the display will blink 3 times to write. If writing is impossible, the numeric value is out of setting range. Check the setting value again.	064.																																																								
9	Return to step 9 of the basic mode setting procedure.																																																										

4. Digital Operator [General parameter mode operations and display]

■ Description of general parameter mode







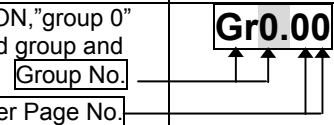

- The following parameters can be set and changed at each page of general parameter mode. Settings can be made suitable for machines and equipment. Parameters for adjusting servo gain can be changed. Classified into 10 groups according to their functions.

Group	Description Group
Group0	Tuning mode setting
Group1	Settings of basic control parameters
Group2	Settings of damping control/notch filter/disturbance observer
Group3	Settings of gain switching control/damping frequency switching
Group4	To set high setting control
Group8	Settings related to system control
Group9	Settings related to general purpose input signals/function condition setting
GroupA	Settings related to general purpose output signals/monitor output signals/Setup software
GroupB	Settings related to system sequence/warning and alarms
GroupC	Settings related to servo motor encoder

 Refer to "Chapter5, Parameter" for details of parameters.

■ How to set the general parameter mode

- See the followings for operations and setting method of general parameters.

Step	Input key	Description	Display
1	MODE	Press the MODE key to display general parameter mode.	Gr
2	----	Page is automatically displayed. Once power is turned ON, "group 0" "Page 00" is displayed and then the previously displayed group and page are displayed. <div style="display: flex; justify-content: flex-end; align-items: center; margin-top: 5px;"> <div style="border: 1px solid black; padding: 2px; margin-right: 5px;">Group No.</div> <div style="border: 1px solid black; padding: 2px; margin-right: 5px;">Parameter Page No.</div>  </div>	Gr0.00
3		Pressing the cursor key makes the blinking LED move. Move the blinking LED to the group or page to be changed.	Gr0.00
4	 	Pressing the UP key increases the blinking numeric value and the Down key decreases.	Gr0.00
5	WR	On the desired group or page, press the WR key to display the data.	Refer to display
6		Pressing the cursor key makes the blinking LED move. Move the blinking LED to the numeric value to be changed.	0000d
7	 	Pressing the UP key increases the blinking numeric value and the Down key decreases.	00000
8	WR	Press the WR key, and the display will blink 3 times to write the data. If writing is impossible, the numeric value is out of setting range. Check the setting value again.	00000
9	MODE	Pressing the MODE key returns to step 2.	Gr0.00
10	MODE	Pressing the MODE key again, returns to status display.	
		When the pages not allocated are set, the display is as shown in the right.	no.dAt

 For setting the dividing ratio of encoder pulse dividing output and electronic gear 1, 2, different procedure is taken at step 5. Refer to page 4-10 for how to set fractions.

4. Digital Operator [General parameter mode operations and display]

Display: integer

Display of "-" data	Display of "+" data	The "+" data is displayed without the mark "+" on LED. The setting ranges of the table below are displayed as shown in the left.
-01000	01000	
	15000	

Name	Setting range	Unit
Position Loop Proportional Gain	1 to 3000	1/s
Load Inertia Ratio (Load Mass Ratio)	0 to 15000	%
Acceleration Feedback Gain	-1000 to +1000	0.1%
Torque Command Filter	1 to 2000	Hz
Torque Command Filter Order	1 to 3	
Acceleration Compensation	-9999 to +9999	Pulse

The above parameters are examples. Refer to "Chapter 5, Parameter" for parameter list.

Display: decimal point

Display of "decimal point" data	The setting ranges of the table below are displayed as shown in the left.
012.00	

Name	Setting range	Unit
Position Command Filter	0.0 to 2000.0	ms
Velocity Loop Integral Time Constant	0.5 to 1000.0	ms

The above parameters are examples. Refer to "Chapter 5, Parameter" for the parameter list.

Display form: fraction

Data display of numerator	Data display of denominator	Denominator is displayed with a dot at its right. The setting ranges of the table below are displayed as shown in the left.
D.0001	00001.	

Name	Setting range
Encoder Output Pulse, Divide Ratio	1/8192 to 1/1
Electric Gear Ratio 1	1/32767 to 32767/1
Electric Gear Ratio 2	1/32767 to 32767/1

How to set fractional data. [Different from step 5 of general parameter mode setting procedure.]

The following example is when the data needs to be changed to 2/64 from the set value of 1/1.

5	WR	On the page to be changed, press the WR key to display the numerator data.	0 1
	▶	Pressing the cursor key makes the blinking LED move. Move the blinking LED to the page to be changed.	0 1
	▲ ▼	Pressing the UP key increases the blinking numeric value and the Down key decreases.	0 2
	WR	Press the WR key, and the display will blink 3 times to write the data. If writing is impossible, the numeric value is out of setting range. Check the setting value again.	0 2
	▼	Press the Down key to display denominator data. Denominator is displayed with a dot at its right.	001.
	▶	Pressing the cursor key makes the blinking LED move. Move the blinking LED to the numeric value to be changed.	001.
	▲ ▼	Pressing the UP key increases the blinking numeric value and the Down key decreases.	064.
	WR	Press the WR key, and the display will blink 3 times to write the data. If writing is impossible, the numeric value is out of setting range. Check the setting value again.	064.
9	Return to step 9 of the general parameter mode setting procedure.		

4.Digital Operator [Operation and display of auto-adjustment mode]





■ Description of auto-adjustment mode

- Automatic Notch Frequency Tuning, automatic Vibration Suppressor Frequency Tuning, automatic offset of Analog Velocity and Torque Command, and Analog Torque Addition Command Auto-Offset can be executed.

MODE	Page	Name
Au	00	Execution of Automatic Notch Frequency Tuning. Note 1)
	01	Execution of Automatic Vibration Suppressor Frequency Tuning Note 1)
	02	Automatic Offset Adjustment of Velocity /Torque Command
	03	Automatic Offset Adjustment of Analog Torque Addition Command

■ How to set the auto-adjustment mode

- See the followings for how to operate and set the auto-adjustment mode.

Step	Input key	Description	Display
1	MODE	Press the MODE key to display auto-adjustment mode.	Au
2	---	Page is displayed automatically. Once the power is turned ON, "Page 00" is displayed then the previously displayed page is displayed.	Au_00
3		Pressing the cursor key makes the blinking LED move. Move the blinking LED to the page to be changed.	Au_00
4		Pressing the UP key increases the blinking numeric value and the Down key decreases.	Au_01
5	WR	On the page to be changed, press the WR key to display execution confirmation.	-y_n-
6		Press the ▲ key for execution.	Proceed to step 7
		Press the ▼ key for cancellation and to return to step 3.	Au_01
7	---	"rdy" is displayed when execution is possible. Move to step 8. Note1)	rdy00
	---	"no.rdy" is displayed when execution is impossible. Press the MODE key to return to step 3.	no.rdy
8	MODE	Press the MODE key for cancellation, and move to step 11 for Auto-Notch and auto-Vibration Suppressor. For Automatic Offset Adjustment of Analog Velocity /Torque Command, Automatic Offset Adjustment of Analog Torque Addition Command, return to step 3.	
	WR	Press the WR key for execution. Display is as shown in the right while Auto-Notch and Auto- Vibration Suppressor are being executed.	r.u.n. .8
9		When completed normally, "-END-" is displayed. "-Err-" is displayed in case of an error.	-End-
10	MODE	Pressing the MODE key returns to step 7 for Auto-Notch and Auto-Vibration Suppressor. For Automatic Offset Adjustment of Analog Velocity /Torque Command, Automatic Offset Adjustment of Analog Torque Addition Command, returns to step 3.	
11		Completes with the display of "AL_dF."	AL dF
 For Auto- Vibration Suppressor, pressing the MODE key during execution of step 8 cancels the execution and moves to step 11.			

 If the control mode switching type is in use, it may not be possible to use this. Switch the control mode at the base side [03: Velo-Torq] to Velo (Velocity control) to use this.

Note1) At the time of Automatic Notch Frequency and Automatic Vibration Suppressor Frequency Tuning, if the main circuit power is shut off in this status, make sure to turn On the main power source again or turn OFF and ON the control power.

4. Digital Operator

[Test run mode operations and display]







■ Description of test run mode

- JOG operation, alarm reset, encoder clear, alarm history clear, and Save Result of Automatic Tuning can be executed.

MODE	Page	Name
Ad	00	Execution of JOG operation (Note 1)
	01	Execution of Alarm Reset
	02	Save Result of Automatic Tuning
	03	Execution of Encoder Clear
	04	Execution of Alarm History Clear

■ How to set the test run mode

- See the followings for how to operate and set the test run mode.

Step	Input key	Description	Display
1	MODE	Press the MODE key to display test run mode.	Ad
2	---	Page is automatically displayed. Once the power source is turned ON, "Page 00" is displayed then the previously displayed page is displayed.	Ad_00
3		Pressing the cursor key makes the blinking LED move. Move the blinking LED to the page to be changed.	Ad_00
4	 	Pressing the UP key increases the blinking numeric value and the Down key decreases.	Ad_00
5	WR	On the page to be changed, press the WR key to display confirmation.	-y_n-
6		Press the  key for execution.	Proceed to step 7
		Press the  key for cancellation and to return to step 3.	Ad_00
7	---	"rdy" is displayed when execution is possible. Move to step 8. Note1)	rdy00
	---	"no.rdy" is displayed when execution is impossible. Press the MODE key to return to step 3.	no.rdy

 On and after step 8, the display and operations differ depending on the function in use. See the following pages for display and operations described separately for each function.

Note1) At the time of JOG operation, if the main circuit power is shut off in this status, press the MODE key or turn ON the main power source again or turn OFF and ON the control power.

4. Digital Operator

[Test run mode operations and display]

- See the followings for how to operate and set JOG operation.

Step	Input key	Description	Display
8	MODE	Press the MODE key for cancellation and to proceed to step 10.	AL dF
	WR	Pressing the WR key displays a number of '8' in servo ON status.	Ad_08
9	▲	Press the ▲ key, and the motor shaft rotates to CCW direction. (Dot moves.)	r.u.n. .8
	▼	Press the ▼ key, and the motor shaft rotates to CW direction. (Dot moves.)	r.u.n. .8
 Command speed at the time of JOG operation shall be set at "general parameter, GroupB_00". If not changed, the rotation will be "50min ⁻¹ " which was set at the time of shipment.			
10	MODE	Press the MODE key, and JOG operation will end. The display shows "AL_dF", which is not an error.	AL dF

 Digital operator cannot perform JOG operation from servo ON status. Servo ON signal from upper device shall be turned OFF. When general parameter "group 9 05" is set to "01:_Always_ON", set this to "00:_Always_OFF" to execute JOG operation.

 If the control mode switching type is in use, it may not be possible to use this. Switch the control mode at the base side [03:_Velo-Torq] to Velo (speed control) to use this.

- See the followings for how to operate Alarm Reset.

Step	Input key	Description	Display
8	MODE	Press the MODE key for cancellation and to return to step 3.	Ad_01
	WR	Press the WR key to reset the alarm and "-End-" will be displayed. While "-Err-" is displayed, alarm cause is not yet eliminated. Take the corrective actions as instructed in "Chapter 8, Maintenance".	-End- -Err-
9	MODE	Press the MODE key to return to step 3.	Ad_01

- See the followings for how to operate Automatic Tuning Result writing / Encoder Clear / Alarm History Clear.

Step	Input key	Description	Display
8	MODE	Press the MODE key for cancellation and to return to step 3.	Ad_02
	WR	Press the WR key, and "run"(while execution) will be displayed in case of encoder clear, and dot moves to right and left.	r.u.n. .
9		When completed normally, "-End-" is displayed. If not "-Err-" is displayed.	-End-
			-Err-
10	MODE	Pressing the MODE key returns to step 7.	Ad_02

 When "Automatic Tuning Result writing" is used at digital operator, it is impossible to write after monitoring the tuning result.







4. Digital Operator [System parameter mode operations and display]

- Description of system parameter mode
 - On each page of the system parameter mode, parameters are set related to combinations and specifications of servo amplifier and servo motor as shown below.

MODE	Page	Name	Setting range
Sy	00	Main Power, Input Type	2 ways (depending on the kind of hardware)
	01	Motor Encoder Type	2 ways (depending on the kind of hardware)
	02	Incremental Encoder, Function Setting	2 ways (depending on the kind of hardware)
	03	Incremental Encoder, Resolution Setting	500P/R to 65535P/R
	04	Absolute Encoder, Function Setting	4ways (depending on the kind of hardware)
	05	Absolute Encoder, Resolution Setting	11ways
	06	Servo amplifier information [editing disabled]	[for a maker maintenance]
	07	Servo Motor Code [editing disabled]	---
	08	Control Mode	6ways
	09	Position Loop Control and Position Loop Encoder Selection	2ways (depending on the kind of hardware)
	0A	External Encoder, Resolution Setting	500P/R to 65535P/R
0B	Regenerative Resistor Selection	3ways	

 Parameter setting becomes effective after control power supply is re-input.

- How to set the system parameter mode
 - See the followings for how to operate and set the system parameter mode.

Step	Input key	Description	Display
1	MODE	Press the MODE key to display system parameter mode.	Sy
2	---	Page is automatically displayed. Once the power source is turned ON, "Page 00" is displayed then the previously displayed page is displayed.	Sy_00
3		Pressing the cursor key makes the blinking LED move. Move the blinking LED to the page to be changed.	Sy_00
4	 	Pressing the UP key increases the blinking numeric value and the Down key decreases.	Sy_0b
5	WR	On the page to be changed, press the WR key to display the data.	00001
6		Pressing the cursor key makes the blinking LED move. Move the blinking LED to the numeric value to be changed.	00001
7	 	Pressing the UP key increases the blinking numeric value and the Down key decreases.	00002
8	WR	Press the WR key, and the display will blink 3 times to write the data. If writing is impossible, the numeric value is out of setting range. Check the setting value again.	00002
9	MODE	Pressing the MODE key returns to step 2.	Sy_0b
10	MODE	Pressing the MODE key again returns to status display.	
		When the pages not allocated are set, the display is as shown in the right.	no.dAt

4. Digital Operator

[Alarm trace/CPU Ver mode operations and display]

■ Description of Alarm trace/CPU_Ver mode

- It is possible to confirm the latest 7 alarms and the software version of servo amplifier CPU.

MODE	Page	Name
AL	1	1st latest alarm
	2	2nd latest alarm
	3	3rd latest alarm
	4	4th latest alarm
	5	5th latest alarm
	6	6th latest alarm
	7	7th latest alarm
		CPU software version

 Refer to "Chapter 8, Maintenance" for details of alarms.

■ How to display the alarm trace mode

- See the followings for how to operate and display the alarm trace mode.

Step	Input key	Description	Display
1	MODE	Press the MODE key to display the alarm trace mode.	AL
2	-- --	Page is automatically displayed. Once the power source is turned ON, [1st latest alarm] is displayed then the previously displayed page is displayed.	AL1.85
3	▲ ▼	Pressing the UP key increases the blinking numeric value and the Down key decreases. The blinking number shows the alarm history.	

■ How to display CPU software version.

- See the followings for how to display the CPU software version.

Step	Input key	Description	Display
1	MODE	Press the MODE key to display system parameter mode.	AL
2	-- --	Page is automatically displayed. Once the power source is turned ON, "1 st latest alarm" is displayed then the previously displayed page is displayed.	AL1.85
3	▲ ▼	Press the Up/Down key, and the display as shown in the right appears.	CPu.no
4	WR	Press the WR key to display the version.	**.*.*
5	MODE	Press the MODE key to return to step 3.	CPu.no

4.Digital Operator

[Password setting]

■ Description of password function

- The password function allows selection of a password and protection against unauthorized parameter changes. Once a password has been set, “status mode” and “monitor mode” can only be used. Utilize this function to avoid operational mistakes.

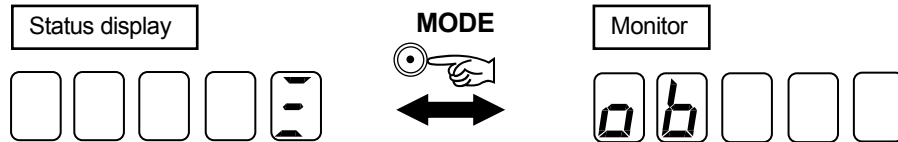

■ How to set and release password

- The following explains how to set and release password.

Step	Input key	Description	Status display
1	MODE	Turn ON the power source or press the MODE key to display the status display mode.	
2	▲	Press the Up key, and the display shown in the right appears.	-PAS-
		Display starts blinking : password not yet set → password setting	-PAS-
		Display turns ON: Password has been set. → Password release	-PAS-
4	WR	Press the WR key to display “0000.”	0000
5	▲ ▼	Pressing the UP key increases the blinking numeric value and the Down key decreases.	01000
		For password setting, use a combination of 4 digit numeric values and alphabets in hexadecimal. To release the password, input the previously set 4 digit password.	
6	WR	Press the WR key, and the display blinks 3 times to write or release the password.	01000
		When writing is disabled, “-Err-“ shows that this is out of setting range. “0000” and “FFFF” are invalid.	-Err-
		When release is disabled, “-Err-“ shows that this is a wrong password.	
7	MODE	Press the MODE key to return to step 1.	

- ✎ For password setting, it is important to make a note of the password and remember it for future reference. Without the password, it is impossible to release the lock function.
- The password function is enabled or disabled by turning OFF the control power and then once again switching it ON. The possible values for a password is a combination of 4 digits from 0 to 9 and A to F. “0000” and “FFFF” are invalid. Setting and release of a password cannot be performed by “Setup software R Setup”. Once a password has been set, parameters cannot be changed via “Setup software R Setup.” If parameters are changed via “Setup software R Setup,” “communication establishment” will be disconnected.

No Text on This Page.

[Parameter]

◆	Parameter List.....	5-1
◆	Parameter setting value 【Group0】	5-8
◆	Parameter setting value 【Group1】	5-9
◆	Parameter setting value 【Group2】	5-11
◆	Parameter setting value 【Group3】	5-14
◆	Parameter setting value 【Group4】 【Group8】	5-16
◆	Parameter setting value 【Group9】	5-22
◆	Parameter setting value 【GroupA】	5-24
◆	Parameter setting value 【GroupB】	5-27
◆	Parameter setting value 【GroupC】	5-30
◆	System parameter setting value	5-32
◆	Block Diagram.....	5-34

5.Parameter

[Parameter list]

■ General Parameter Group 0 [Auto-tuning setting]

Page	Symbol	Name	Standard Value	Unit	Display Range	Reference page
00	TUNMODE	Tuning mode	00:_AutoTun	-	00 to 02	5-8
01	ATCHA	Automatic Tuning Characteristic	00:_Positioning1	-	00 to 04	5-8
02	ATRES	Automatic Tuning Response	5	-	1 to 30	5-8
03	ATSAVE	Automatic Tuning, Automatic Parameter Saving	00:_Auto_Saving	-	00 to 01	5-8
10	ANFILTC	Automatic Notch Filter Tuning, Torque Command	50	%	10 to 100	5-8
20	ASUPTC	Automatic Vibration Suppressor Frequency Tuning, Torque Command	25	%	10 to 100	5-8
21	ASUPFC	Automatic Vibration Suppressor Frequency Tuning, Friction Compensation Value	5	%	0 to 50	5-8

■ General Parameter Group 1 [Basic controlling parameter setting]

Page	Symbol	Name	Standard Value	Unit	Display Range	Reference page
01	PCFIL	Position command filter	0.0	ms	0.0 to 2000.0	5-9
02	KP1	Position Loop Proportional Gain 1	30	1/s	1 to 3000	5-9
03	TP11	Position Loop Integral Time Constant 1	1000.0	ms	0.5 to 1000.0	5-9
04	TRCPGN	Higher Tracking Control, Position Compensation Gain	0	%	0 to 100	5-9
05	FFGN	Feed Forward Gain	0	%	0 to 100	5-9
08	FFFIL	Feed Forward Filter	2000	Hz	1 to 2000	5-9
10	VCFIL	Velocity Command Filter	2000	Hz	1 to 2000	5-9
12	VDFIL	Velocity Feedback Filter	1500	Hz	1 to 2000	5-9
13	KVP1	Velocity Loop Proportional Gain 1	50	Hz	1 to 2000	5-9
14	TVI1	Velocity Loop Integral Time Constant 1	20.0	ms	0.5 to 1000.0	5-9
15	JRAT1	Load Inertia Ratio (Load Mass Ratio) 1	100	%	0 to 15000	5-10
16	TRCVGN	Higher Tracking Control, Velocity Compensation Gain	0	%	0 to 100	5-10
17	AFBK	Acceleration Feedback Gain	0.0	%	-100.0 to 100.0	5-10
18	AFBFIL	Acceleration Feedback Filter	500	Hz	1 to 2000	5-10
20	TCFIL1	Torque Command Filter 1	600	Hz	1 to 2000	5-10
21	TCFILOR	Torque Command Filter Order	2	Order	1 to 3	5-10

* When manual tuning, set the [Page 16: high tracking control position compensation gain] at 100% to bring conditions in line with Q-Series standard characteristics.

■ General Parameter Group 2

[Vibration suppressing control/ Notch filter/ Disturbance observer setting]

Page	Symbol	Name	Standard Value	Unit	Display Range	Reference page
00	SUPFRQ1	Vibration Suppressor Frequency 1	500	Hz	5 to 500	5-11
01	SUPLV	Vibration Suppressor Level Selection	00	-	00 to 03	5-11
10	VCNFIL	Velocity Command, Notch Filter	500	Hz	50 to 500	5-11
20	TCNFILA	Torque Command, Notch Filter A	2000	Hz	100 to 2000	5-11
21	TCNFPA	TCNFILA, Low Frequency Phase Delay Improvement	00	-	00 to 02	5-12
22	TCNFILB	Torque Command, Notch Filter B	2000	Hz	100 to 2000	5-12
23	TCNFDB	TCNFILB, Depth Selection	00	-	00 to 03	5-12
24	TCNFILC	Torque Command, Notch Filter C	2000	Hz	100 to 2000	5-12
25	TCNFDC	TCNFILC, Depth Selection	00	-	00 to 03	5-12
26	TCNFILD	Torque Command, Notch Filter D	2000	Hz	100 to 2000	5-12
27	TCNFDD	TCNFILD, Depth Selection	00	-	00 to 03	5-13
30	OBCHA	Observer characteristic	00:_Low	-	00 to 01	5-13
31	OBG	Observer Compensation Gain	0	%	0 to 100	5-13
32	OBLPF	Observer Output, Low Pass Filter	50	Hz	1 to 2000	5-13
33	OBNFIL	Observer Output, Notch Filter	2000	Hz	100 to 2000	5-13

5.Parameter

[Parameter list]

■ General Parameter Group 3

[Setting for gain switching control/ vibration suppressing frequency switching]

Page	Symbol	Name	Standard Value	Unit	Display Range	Reference page
00	KP2	Position Loop Proportional Gain 2	30	1/s	1 to 3000	5-14
01	TPI2	Position Loop Integral Time Constant 2	1000.0	ms	0.5 to 1000.0	5-14
02	KVP2	Velocity Loop Proportional Gain 2	50	Hz	1 to 2000	5-14
03	TVI2	Velocity Loop Integral Time Constant 2	20.0	ms	0.5 to 1000.0	5-14
04	JRAT2	Load Inertia Ratio (Load Mass Ratio) 2	100	%	0 to 15000	5-14
05	TCFIL2	Torque Command Filter 2	600	Hz	1 to 2000	5-14
10	KP3	Position Loop Proportional Gain 3	30	1/s	1 to 3000	5-14
11	TPI3	Position Loop Integral Time Constant 3	1000.0	ms	0.5 to 1000.0	5-14
12	KVP3	Velocity Loop Proportional Gain 3	50	Hz	1 to 2000	5-14
13	TVI3	Velocity Loop Integral Time Constant 3	20.0	ms	0.5 to 1000.0	5-14
14	JRAT3	Load Inertia Ratio (Load Mass Ratio) 3	100	%	0 to 15000	5-14
15	TCFIL3	Torque Command Filter 3	600	Hz	1 to 2000	5-14
20	KP4	Position Loop Proportional Gain 4	30	1/s	1 to 3000	5-15
21	TPI4	Position Loop Integral Time Constant 4	1000.0	ms	0.5 to 1000.0	5-15
22	KVP4	Velocity Loop Proportional Gain 4	50	Hz	1 to 2000	5-15
23	TVI4	Velocity Loop Integral Time Constant 4	20.0	ms	0.5 to 1000.0	5-15
24	JRAT4	Load Inertia Ratio (Load Mass Ratio) 4	100	%	0 to 15000	5-15
25	TCFIL4	Torque Command Filter 4	600	Hz	1 to 2000	5-15
30	GCFIL	Low Pass Filter of Gain Switching	0	ms	0 to 100	5-15
40	SUPFRQ2	Vibration Suppressor Frequency 2	500	Hz	5 to 500	5-15
41	SUPFRQ3	Vibration Suppressor Frequency 3	500	Hz	5 to 500	5-15
42	SUPFRQ4	Vibration Suppressor Frequency 4	500	Hz	5 to 500	5-15

■ General Parameter Group 4 [To set high setting control]

Page	Symbol	Name	Standard Value	Unit	Display Range	Reference page
00	CVFIL	Command Velocity, Low Pass Filter	1000	Hz	1 to 2000	5-16
01	CVTH	Command Velocity Threshold	20	min ⁻¹	0 to 65535	5-16
02	ACCC0	Acceleration Compensation	0	×50 Pulse	-9999 to +9999	5-16
03	DECC0	Deceleration Compensation	0	×50 Pulse	-9999 to +9999	5-16

5.Parameter

[Parameter list]

■ General Parameter Group 8 [Control system setting]

Page	Symbol	Name	Standard Value	Unit	Display Range	Reference page
00	CMDPOL	Command Input Polarity	00:_PC+_VC+_TC+	-	00 to 07	5-16
01	VC/TC-DB	Analog Input Dead Band	00:_Disabled	-	00 to 01	5-16
02	VCZDAT	Analog Input Dead Band Width	0.0	mV	0.0 to 6553.5	5-17
11	PCPTYP	Position Command Pulse, Form Selection	00:_F-PC_R-PC	-	00 to 02	5-17
12	PCPPOL	Position Command Pulse, Count Polarity	00:_Type1	-	00 to 03	5-17
13	PCPFIL	Position Command Pulse, Digital Filter	00:_834nsec	-	00 to 07	5-17
14	PCPMUL	Position Command, Pulse Multiplier	1	-	1 to 63	5-17
15	GER1	Electric Gear Ratio 1	1/1	-	1/32767 to 32767/1	5-17
16	GER2	Electric Gear Ratio 2	1/1	-	1/32767 to 32767/1	5-17
17	EDGEPOS	Positioning method	00:_Pulse_Interval	-	00 to 01	5-18
18	PDEVMON	Inposition / Position Deviation Monitor	00:_After_Filter	-	00 to 01	5-18
19	CLR	Deviation Clear Selection	00:_Type1	-	00 to 03	5-18
20	VC1	Preset Velocity Command 1	100	min ⁻¹	0 to 32767	5-18
21	VC2	Preset Velocity Command 2	200	min ⁻¹	0 to 32767	5-18
22	VC3	Preset Velocity Command 3	300	min ⁻¹	0 to 32767	5-18
23	VCOMSEL	Velocity Compensation Command, Input Selection	02:_VCOMP	-	01 to 02	5-18
24	VCOMP	Preset Velocity Compensation Command	0	min ⁻¹	-9999 to +9999	5-18
25	VCGN	Analog Velocity Command, Reference (Analog Velocity Compensation Command, Ref.)	500	min ⁻¹ /V	0 to 4000	5-19
26	TVCACC	Velocity Command, Acceleration Time Constant	0	ms	0 to 16000	5-19
27	TVCDEC	Velocity Command, Deceleration Time Constant	0	ms	0 to 16000	5-19
28	VCLM	Velocity Limit	65535	min ⁻¹	1 to 65535	5-19
30	TCOMSEL	Torque Compensation Command, Input Selection	02:_TCOMP	-	01 to 02	5-19
31	TCOMP1	Preset Torque Compensation Command 1	0	%	-500 to 500	5-19
32	TCOMP2	Preset Torque Compensation Command 2	0	%	-500 to 500	5-19
33	TCGN	Analog Torque Command, Reference	50	%/V	0 to 500	5-19
34	TCOMPGN	Analog Torque Compensation Command, Reference	50	%/V	0 to 500	5-19
35	TLSEL	Torque Limit, Input Selection	00:_TCLM	-	00 to 03	5-20
36	TCLM	Internal Torque Limit	100	%	10 to 500	5-20
37	SQTCLM	Torque Limit at Sequence Operation	120	%	10 to 500	5-20
40	NEAR	In-Position Near Range	500	Pulse	1 to 65535	5-20
41	INP	In-Position Window	100	Pulse	1 to 65535	5-20
42	ZV	Speed Zero Range	50	min ⁻¹	50 to 500	5-20
43	LOWV	Low Speed Range	50	min ⁻¹	0 to 65535	5-21
44	VCOMP	Speed Matching Width	50	min ⁻¹	0 to 65535	5-21
45	VA	High Speed Range	1000	min ⁻¹	0 to 65535	5-21

As for the parameter, setting becomes effective after control power supply re-input.

5.Parameter

[Parameter list]

■ General Parameter Group 9 [Function enabling condition setting]

Page	Symbol	Name	Standard Value	Display Range	Reference page
00	F-OT	Positive Over-Travel Function	0D:_CONT6_OFF	00 to 27	5-22,23
01	R-OT	Negative Over-Travel Function	0B:_CONT5_OFF	00 to 27	5-22,23
02	AL-RST	Alarm Reset Function	10:_CONT8_ON	00 to 27	5-22,23
03	ECLR	Absolute Encoder Clear Function	06:_CONT3_ON	00 to 27	5-22,23
04	CLR	Deviation Clear Function	08:_CONT4_ON	00 to 27	5-22,23
05	S-ON	SERVO-ON Function	02:_CONT1_ON	00 to 27	5-22,23
10	MS	Control Mode Switching Function	00:_Always_Disable	00 to 27	5-22,23
11	INH/Z-STP	Position Command Pulse Inhibit Function and Velocity Command Zero Clamp Function	00:_Always_Disable	00 to 27	5-22,23
12	GERS	Electric Gear Switching Function	00:_Always_Disable	00 to 27	5-22,23
13	GC1	Gain Switching Function, Select Input 1	00:_Always_Disable	00 to 27	5-22,23
14	GC2	Gain Switching Function, Select Input 2	00:_Always_Disable	00 to 27	5-22,23
15	SUPFSEL1	Vibration Suppressor Frequency, Select Input 1	00:_Always_Disable	00 to 27	5-22,23
16	SUPFSEL2	Vibration Suppressor Frequency, Select Input 2	00:_Always_Disable	00 to 27	5-22,23
17	PLPCON	Position Loop Proportional Control, Switching Function	01:_Always_Enable	00 to 27	5-22,23
20	SP1	Preset Velocity Command, Select Input 1	00:_Always_Disable	00 to 27	5-22,23
21	SP2	Preset Velocity Command, Select Input 2	00:_Always_Disable	00 to 27	5-22,23
22	DIR	Preset Velocity Command, Direction of Move	00:_Always_Disable	00 to 27	5-22,23
23	RUN	Preset Velocity Command, Operation Start Signal Input	00:_Always_Disable	00 to 27	5-22,23
24	RUN-F	Preset Velocity Command, Positive Move Signal Input	00:_Always_Disable	00 to 27	5-22,23
25	RUN-R	Preset Velocity Command, Negative Move Signal Input	00:_Always_Disable	00 to 27	5-22,23
26	VLPCON	Velocity Loop Proportional Control, Switching Function	04:_CONT2_ON	00 to 27	5-22,23
27	VCOMPS	Velocity Compensation Function, Select Input	00:_Always_Disable	00 to 27	5-22,23
30	TCOMPS1	Torque Compensation Function, Select Input 1	00:_Always_Disable	00 to 27	5-22,23
31	TCOMPS2	Torque Compensation Function, Select Input 2	00:_Always_Disable	00 to 27	5-22,23
32	TL	Torque Limit, Input Selection	0E:_CONT7_ON	00 to 27	5-22,23
33	OBS	Disturbance Observer	00:_Always_Disable	00 to 27	5-22,23
40	EXT-E	External Error Input	00:_Always_Disable	00 to 27	5-22,23
41	DISCHARG	Main Power Discharge Function	01:_Always_Enable	00 to 27	5-22,23
42	EMR	Emergency Stop Function	00:_Always_Disable	00 to 27	5-22,23

■ General Parameter Group A

[Setting for output condition of general output terminal/monitor output selection/setup software]

Page	Symbol	Name	Standard Value	Display Range	Reference page
00	OUT1	General Purpose Output 1	18:_INP_ON	00 to 5B	5-24,25
01	OUT2	General Purpose Output 2	0C:_TLC_ON	00 to 5B	5-24,25
02	OUT3	General Purpose Output 3	02:_S-RDY_ON	00 to 5B	5-24,25
03	OUT4	General Purpose Output 4	0A:_MBR_ON	00 to 5B	5-24,25
04	OUT5	General Purpose Output 5	33:_ALM5_OFF	00 to 5B	5-24,25
05	OUT6	General Purpose Output 6	35:_ALM6_OFF	00 to 5B	5-24,25
06	OUT7	General Purpose Output 7	37:_ALM7_OFF	00 to 5B	5-24,25
07	OUT8	General Purpose Output 8	39:_ALM_OFF	00 to 5B	5-24,25
10	DMON	Digital Monitor, Output Signal Selection	00:_Always_OFF	00 to 5B	5-24,25
11	MON1	Analog Monitor 1, Output Signal Selection	05:_VMON_2mV/min ⁻¹	00 to 15	5-24,25
12	MON2	Analog Monitor 2, Output Signal Selection	02:_TCMON_2V/TR	00 to 15	5-24,25
13	MONPOL	Analog monitor output polarity	00:_MON1+_MON2+	00 to 08	5-26
20	COMAXIS	Setup Software, Communication Axis Number	01:_#1	01 to 0F	5-26
21	COMBAUD	Setup Software, Communication Baud Rate	05:_38400bps	00 to 05	5-26

Parameter setting becomes effective after control power supply is re-input.

5.Parameter

[Parameter list]

■ General Parameter Group B [Setting related to sequence/alarms]

Page	Symbol	Name	Standard Value	Unit	Display Range	Reference page
00	JOGVC	JOG Velocity Command	50	min ⁻¹	0 to 32767	5-27
10	DBOPE	Dynamic Brake Action Selection	04:_SB_Free	-	00 to 05	5-27
11	ACTOT	Over-Travel Action Selection	00:_CMDINH_SB_SON	-	00 to 06	5-27
12	ACTEMR	Emergency Stop Operation	00:_SERVO-BRAKE	-	00 to 01	5-27
13	BONDLY	Delay Time of Engaging Holding Brake (holding brake holding delay time)	300	ms	0 to 1000	5-28
14	BOFFDLY	Delay Time of Releasing Holding Brake (holding brake release delay time)	300	ms	0 to 1000	5-28
15	BONBGN	Brake Operation Beginning Time	0	ms	0 to 65535	5-28
16	PFDDLY	Power Failure Detection Delay Time	32	ms	20 to 1000	5-28
20	OFWLV	Following Error Warning Level	65535	X1024 pulse	1 to 65535	5-28
21	OFLV	Following Error Limit	500	X1024 pulse	1 to 65535	5-28
22	OLWLV	Overload Warning Level	90	%	20 to 100	5-29
23	VFBALM	Speed Feedback Error (ALM_C3) Detection	01:_Enabled	-	00 to 01	5-29
24	VCALM	Speed Control Error (ALM_C2) Detection	00:_Disabled	-	00 to 01	5-29

As for the parameter, setting becomes effective after control power supply re-input.

■ General Parameter Group C [Encoder related setting]

Page	Symbol	Name	Standard Value	Unit	Display Range	Reference page
00	ABS/INCSYS	Position detection system choice	00:_Absolute	--	00 to 01	5-30
01	ENFIL	Motor Incremental Encoder, Digital Filter	01:_220nsec	-	00 to 07	5-30
02	EX-ENFIL	External Incremental Encoder, Digital Filter	01:_220nsec	-	00 to 07	5-30
03	EX-ENPOL	External Encoder Polarity Invert	00:_Type1	-	00 to 07	5-30
04	PULOUTSEL	Encoder Pulse Divided Output, Selection	00:_Motor_Enc.	-	00 to 01	5-31
05	ENRAT	Encoder Output Pulse, Divide Ratio	1/1	-	1/8192 to 1/1	5-31
06	PULOUTPOL	Encoder Pulse Divided output, Polarity	00:_Type1	-	00 to 03	5-31
07	PSOFORM	Encoder Signal Output (PS), Format	00:_Binary	-	00 to 02	5-31
08	ECLRFUNC	Abusolute Encoder Clear Function Selection	00:_Status_MultiTurn	-	00 to 01	5-31

As for the parameter, setting becomes effective after control power supply re-input.



To the customers using “Absolute encoder for incremental system” with R motor; Please set the setting of the parameter of the table below value to the servo amplifier.

Group	Page	Symbol	Name	Setting value	contents
C	00	ABS/INCSYS	Position detection system choice	00:_Absolute	Absolute system
C	08	ECLRFUNC	Abusolute Encoder Clear Function Selection	01:_Status	Clear Only Encoder Status

As for the parameter, setting becomes effective after control power supply re-input.



To the customers using “Battery backup method absolute encoder” with incremental system with Q motor; Please set the setting of the parameter of the table below value to the servo amplifier.

Group	Page	Symbol	Name	Setting value	contents
C	00	ABS/INCSYS	Position detection system choice	01:_Incremental	Absolute system
C	08	ECLRFUNC	Abusolute Encoder Clear Function Selection	01:_Status	Clear Only Encoder Status

As for the parameter, setting becomes effective after control power supply re-input.

Encoder specifications

Type	Within 1 rotation	Multiple rotation	Notes
PA035C	131072(17bit)	65536(16bit)	Battery backup method absolute encoder
PA035S	131072(17bit)	-	Absolute encoder for incremental system 



To the customers using “Battery backup method absolute encoder” with incremental system:
See the parameter set values for your servo amplifier in the table below and make sure to use them.
General parameter

Group	Page	Symbol	Name	Setting value	contents
C	00	ABS/INCSYS	Position detection system choice	01:_Incremental	Absolute system
C	08	ECLRFUNC	Abusolute Encoder Clear Function Selection	01:_Status	Clear Only Encoder Status

5.Parameter

[Parameter list]

■ Basic Parameters [Digital Operator basic mode]

Page	Name	Group and Page	Standard Value	Display Range	Reference page
00	Setup Software, Communication Axis Number	GroupA 20	01: _#1	01 to 0F	5-26
01	Setup Software, Communication Baud Rate	GroupA 21	05: _38400bps	00 to 05	5-26
02	Tuning Mode	Group0 00	00: _AutoTun	00 to 02	5-8
03	Automatic Tuning Response	Group0 02	5	1 to 30	5-8
04	Position Command Filter [ms]	Group1 01	0.0	0.0 to 2000.0	5-9
05	Electric Gear Ratio 1	Group8 15	1/1	1/32767 to 32767/1	5-17
06	In-Position Window [pulse]	Group8 41	100	1 to 65535	5-20
07	Positive Over-Travel Function	Group9 00	0D: _CONT6_OFF	00 to 27	5-22,23
08	Negative Over-Travel Function	Group9 01	0B: _CONT5_OFF		5-22,23
09	Alarm Reset Function	Group9 02	10: _CONT8_ON		5-22,23
0A	Absolute Encoder Clear Function	Group9 03	06: _CONT3_ON		5-22,23
0B	Deviation Clear Function	Group9 04	08: _CONT4_ON		5-22,23
0C	SERVO-ON Function	Group9 05	02: _CONT1_ON		5-22,23
0D	Torque Limit, Input Selection	Group9 32	0E: _CONT7_ON		5-22,23
0E	JOG Velocity Command	GroupB 00	50	0 to 32767	5-27
0F	Encoder Output Pulse, Divide Ratio	GroupC 05	1/1	1/8192 to 1/1	5-31
10	Analog Velocity Command Offset	----	0	-9999 to 9999	---

■ System parameters [for setup software R-Setup]

Page	Name	Display Range	Reference page
00	Main Power, Input Type	2 ways (depending on the hardware type)	5-32
01	Motor Encoder Type	2 ways (depending on the hardware type)	5-32
02	Incremental Encoder, Function Setting	2 ways (depending on the hardware type)	5-32
03	Incremental Encoder, Resolution Setting	500P/R to 65535P/R	5-32
04	Absolute Encoder, Function Setting	4 ways (depending on the hardware type)	5-32
05	Absolute Encoder, Resolution Setting	11ways	5-32
06	Motor Type	-	5-33
08	Control Mode	6 ways	5-33
09	Position Loop Control and Position Loop Encoder Selection	2ways (depending on the hardware type)	5-33
0A	External Encoder, Resolution Setting	500P/R to 65535P/R	5-33
0B	Regenerative Resistor Selection	3ways	5-33

■ System parameters [for Digital Operator]

Page	Name	Display Range	Reference page
00	Main Power, Input Type	2 ways (depending on the hardware type)	5-32
01	Motor Encoder Type	2ways (depending on the hardware type)	5-32
02	Incremental Encoder, Function Setting	2ways (depending on the hardware type)	5-32
03	Incremental Encoder, Resolution Setting	500P/R to 65535P/R	5-32
04	Absolute Encoder, Function Setting	4ways (depending on the hardware type)	5-32
05	Absolute Encoder, Resolution Setting	11ways	5-32
06	Information of Servo Amplifier	[for maker maintenance]	5-33
07	Servo Motor Code	-	5-33
08	Control Mode	6ways	5-33
09	Position Loop Control and Position Loop Encoder Selection	2ways (depending on the hardware type)	5-33
0A	External Encoder, Resolution Setting	500P/R to 65535P/R	5-33
0B	Regenerative Resistor Selection	3ways	5-33

5.Parameter

[Parameter setting value[Group0]]

■ General parameter Group 0 [Auto-tuning settings]

Page	Contents																		
00	Tuning mode [TUNMODE]																		
	<table border="1"> <thead> <tr> <th>Setting range</th> <th>Unit</th> <th>Standard value</th> </tr> </thead> <tbody> <tr> <td>00 to 02</td> <td>-</td> <td>00:_AutoTun</td> </tr> </tbody> </table>	Setting range	Unit	Standard value	00 to 02	-	00:_AutoTun	<table border="1"> <thead> <tr> <th>Selection</th> <th>Contents</th> </tr> </thead> <tbody> <tr> <td>00:_AutoTun</td> <td>Automatic Tuning</td> </tr> <tr> <td>01:_AutoTun_JRAT-Fix</td> <td>Automatic Tuning (JRAT Fixed)</td> </tr> <tr> <td>02:_ManualTun</td> <td>Manual Tuning</td> </tr> </tbody> </table>	Selection	Contents	00:_AutoTun	Automatic Tuning	01:_AutoTun_JRAT-Fix	Automatic Tuning (JRAT Fixed)	02:_ManualTun	Manual Tuning			
Setting range	Unit	Standard value																	
00 to 02	-	00:_AutoTun																	
Selection	Contents																		
00:_AutoTun	Automatic Tuning																		
01:_AutoTun_JRAT-Fix	Automatic Tuning (JRAT Fixed)																		
02:_ManualTun	Manual Tuning																		
01	Automatic Tuning Characteristic [ATCHA]																		
	<table border="1"> <thead> <tr> <th>Setting range</th> <th>Unit</th> <th>Standard value</th> </tr> </thead> <tbody> <tr> <td>00 to 04</td> <td>-</td> <td>00:_Positioning1</td> </tr> </tbody> </table>	Setting range	Unit	Standard value	00 to 04	-	00:_Positioning1	<table border="1"> <thead> <tr> <th>Selection</th> <th>Contents</th> </tr> </thead> <tbody> <tr> <td>00:_Positioning1</td> <td>Positioning Control 1</td> </tr> <tr> <td>01:_Positioning2</td> <td>Positioning Control 2</td> </tr> <tr> <td>02:_Positioning3</td> <td>Positioning Control 3</td> </tr> <tr> <td>03:_Trajectory1</td> <td>Trajectory Control</td> </tr> <tr> <td>04:_Trajectory2</td> <td>Trajectory Control (KP Fixed)</td> </tr> </tbody> </table>	Selection	Contents	00:_Positioning1	Positioning Control 1	01:_Positioning2	Positioning Control 2	02:_Positioning3	Positioning Control 3	03:_Trajectory1	Trajectory Control	04:_Trajectory2
Setting range	Unit	Standard value																	
00 to 04	-	00:_Positioning1																	
Selection	Contents																		
00:_Positioning1	Positioning Control 1																		
01:_Positioning2	Positioning Control 2																		
02:_Positioning3	Positioning Control 3																		
03:_Trajectory1	Trajectory Control																		
04:_Trajectory2	Trajectory Control (KP Fixed)																		
02	Automatic Tuning Response [ATRES]																		
	<table border="1"> <thead> <tr> <th>Setting range</th> <th>Unit</th> <th>Standard value</th> </tr> </thead> <tbody> <tr> <td>1 to 30</td> <td>-</td> <td>5</td> </tr> </tbody> </table>	Setting range	Unit	Standard value	1 to 30	-	5	Sets the auto-tuning response. The larger the set value, the higher the response. Make the setting suitable for rigidity of the device.											
Setting range	Unit	Standard value																	
1 to 30	-	5																	
03	Automatic Tuning, Automatic Parameter Saving [ATSAVE]																		
	<table border="1"> <thead> <tr> <th>Setting range</th> <th>Unit</th> <th>Standard value</th> </tr> </thead> <tbody> <tr> <td>00 to 01</td> <td>-</td> <td>00:_Auto_Saving</td> </tr> </tbody> </table>	Setting range	Unit	Standard value	00 to 01	-	00:_Auto_Saving	<p>The parameter (JRAT) obtained from auto-tuning result is automatically saved.</p> <table border="1"> <thead> <tr> <th>Selection</th> <th>Contents</th> </tr> </thead> <tbody> <tr> <td>00:_Auto_Saving</td> <td>Saves Parameter Automatically in JRAT1.</td> </tr> <tr> <td>01:_No_Saving</td> <td>Automatic Saving is Invalidity</td> </tr> </tbody> </table>	Selection	Contents	00:_Auto_Saving	Saves Parameter Automatically in JRAT1.	01:_No_Saving	Automatic Saving is Invalidity					
Setting range	Unit	Standard value																	
00 to 01	-	00:_Auto_Saving																	
Selection	Contents																		
00:_Auto_Saving	Saves Parameter Automatically in JRAT1.																		
01:_No_Saving	Automatic Saving is Invalidity																		
10	Automatic Notch Filter Tuning, Torque Command [ANFILTC]																		
	<table border="1"> <thead> <tr> <th>Setting range</th> <th>Unit</th> <th>Standard value</th> </tr> </thead> <tbody> <tr> <td>10 to 100</td> <td>%</td> <td>50</td> </tr> </tbody> </table>	Setting range	Unit	Standard value	10 to 100	%	50	<p>Sets the torque command value applied to the motor at the time of auto-notch filter tuning.</p> <p>Larger value makes the tuning more accurate; however, note that it also makes the move of the machine larger.</p>											
Setting range	Unit	Standard value																	
10 to 100	%	50																	
20	Automatic Vibration Suppressor Frequency Tuning, Torque Command [ASUPTC]																		
	<table border="1"> <thead> <tr> <th>Setting range</th> <th>Unit</th> <th>Standard value</th> </tr> </thead> <tbody> <tr> <td>10 to 100</td> <td>%</td> <td>25</td> </tr> </tbody> </table>	Setting range	Unit	Standard value	10 to 100	%	25	<p>Sets the torque command value applied to the motor at the time of auto-vibration suppressing frequency tuning.</p> <p>Larger value makes the tuning more accurate, however, note that it also makes the move of the machine larger.</p>											
Setting range	Unit	Standard value																	
10 to 100	%	25																	
21	Automatic Vibration Suppressor Frequency Tuning, Friction Compensation Value [ASUPFC]																		
	<table border="1"> <thead> <tr> <th>Setting range</th> <th>Unit</th> <th>Standard value</th> </tr> </thead> <tbody> <tr> <td>0 to 50</td> <td>%</td> <td>5</td> </tr> </tbody> </table>	Setting range	Unit	Standard value	0 to 50	%	5	<p>Sets the friction torque compensation added to the motor torque at the time of auto-vibration suppressing frequency tuning. Set this value close to actual friction torque, and vibration suppressing frequency tuning will be more accurate.</p>											
Setting range	Unit	Standard value																	
0 to 50	%	5																	

5.Parameter

[Parameter setting value[Group1]]

■ General parameter Group 1 [Basic control parameter setting]

Page	Contents						
01	Position command filter [PCFIL]						
	<table border="1"> <thead> <tr> <th>Setting range</th> <th>Unit</th> <th>Standard value</th> </tr> </thead> <tbody> <tr> <td>0.0 to 2000.0</td> <td>ms</td> <td>0.0</td> </tr> </tbody> </table>	Setting range	Unit	Standard value	0.0 to 2000.0	ms	0.0
Setting range	Unit	Standard value					
0.0 to 2000.0	ms	0.0					
02	Position Loop Proportional Gain 1 [KP1]						
	<table border="1"> <thead> <tr> <th>Setting range</th> <th>Unit</th> <th>Standard value</th> </tr> </thead> <tbody> <tr> <td>1 to 3000</td> <td>1/s</td> <td>30</td> </tr> </tbody> </table>	Setting range	Unit	Standard value	1 to 3000	1/s	30
Setting range	Unit	Standard value					
1 to 3000	1/s	30					
03	Position Loop Integral Time Constant 1 [TPI1]						
	<table border="1"> <thead> <tr> <th>Setting range</th> <th>Unit</th> <th>Standard value</th> </tr> </thead> <tbody> <tr> <td>0.5 to 1000.0</td> <td>ms</td> <td>1000.0</td> </tr> </tbody> </table>	Setting range	Unit	Standard value	0.5 to 1000.0	ms	1000.0
Setting range	Unit	Standard value					
0.5 to 1000.0	ms	1000.0					
04	Higher Tracking Control, Position Compensation Gain [TRCPGN]						
	<table border="1"> <thead> <tr> <th>Setting range</th> <th>Unit</th> <th>Standard value</th> </tr> </thead> <tbody> <tr> <td>0 to 100</td> <td>%</td> <td>0</td> </tr> </tbody> </table>	Setting range	Unit	Standard value	0 to 100	%	0
Setting range	Unit	Standard value					
0 to 100	%	0					
05	Feed Forward Gain [FFGN]						
	<table border="1"> <thead> <tr> <th>Setting range</th> <th>Unit</th> <th>Standard value</th> </tr> </thead> <tbody> <tr> <td>0 to 100</td> <td>%</td> <td>0</td> </tr> </tbody> </table>	Setting range	Unit	Standard value	0 to 100	%	0
Setting range	Unit	Standard value					
0 to 100	%	0					
08	Feed Forward Filter [FFFIL]						
	<table border="1"> <thead> <tr> <th>Setting range</th> <th>Unit</th> <th>Standard value</th> </tr> </thead> <tbody> <tr> <td>1 to 2000</td> <td>Hz</td> <td>2000</td> </tr> </tbody> </table>	Setting range	Unit	Standard value	1 to 2000	Hz	2000
Setting range	Unit	Standard value					
1 to 2000	Hz	2000					
10	Velocity Command Filter [VCFIL]						
	<table border="1"> <thead> <tr> <th>Setting range</th> <th>Unit</th> <th>Standard value</th> </tr> </thead> <tbody> <tr> <td>1 to 2000</td> <td>Hz</td> <td>2000</td> </tr> </tbody> </table>	Setting range	Unit	Standard value	1 to 2000	Hz	2000
Setting range	Unit	Standard value					
1 to 2000	Hz	2000					
12	Velocity Feedback Filter [VDFIL]						
	<table border="1"> <thead> <tr> <th>Setting range</th> <th>Unit</th> <th>Standard value</th> </tr> </thead> <tbody> <tr> <td>1 to 2000</td> <td>Hz</td> <td>1500</td> </tr> </tbody> </table>	Setting range	Unit	Standard value	1 to 2000	Hz	1500
Setting range	Unit	Standard value					
1 to 2000	Hz	1500					
13	Velocity Loop Proportional Gain 1 [KVP1]						
	<table border="1"> <thead> <tr> <th>Setting range</th> <th>Unit</th> <th>Standard value</th> </tr> </thead> <tbody> <tr> <td>1 to 2000</td> <td>Hz</td> <td>50</td> </tr> </tbody> </table>	Setting range	Unit	Standard value	1 to 2000	Hz	50
Setting range	Unit	Standard value					
1 to 2000	Hz	50					
14	Velocity Loop Integral Time Constant 1 [TVI1]						
	<table border="1"> <thead> <tr> <th>Setting range</th> <th>Unit</th> <th>Standard value</th> </tr> </thead> <tbody> <tr> <td>0.5 to 1000.0</td> <td>ms</td> <td>20.0</td> </tr> </tbody> </table>	Setting range	Unit	Standard value	0.5 to 1000.0	ms	20.0
Setting range	Unit	Standard value					
0.5 to 1000.0	ms	20.0					

5.Parameter

[Parameter setting value [Group1]]

Page	Contents							
15	Load Inertia Ratio (Load Mass Ratio) 1 [JRAT1]							
	<table border="1"> <thead> <tr> <th>Setting range</th> <th>Unit</th> <th>Standard value</th> </tr> </thead> <tbody> <tr> <td>0 to 15000</td> <td>%</td> <td>100</td> </tr> </tbody> </table>	Setting range	Unit	Standard value	0 to 15000	%	100	Sets inertia moment of the loading device to the motor inertia moment. Set value = $JL/JM \times 100\%$ JL: Load inertia moment JM: Motor inertia moment When auto-tuning result saving is executed, the tuning result is automatically saved in this parameter.
Setting range	Unit	Standard value						
0 to 15000	%	100						
16	Higher Tracking Control, Velocity Compensation Gain [TRCVGN]							
	<table border="1"> <thead> <tr> <th>Setting range</th> <th>Unit</th> <th>Standard value</th> </tr> </thead> <tbody> <tr> <td>0 to 100</td> <td>%</td> <td>0</td> </tr> </tbody> </table>	Setting range	Unit	Standard value	0 to 100	%	0	Parameter to enhance following-up performance. The larger value can make the following-up performance higher. When velocity loop proportional control switching function is used, set this to 0%.
Setting range	Unit	Standard value						
0 to 100	%	0						
17	Acceleration Feedback Gain [AFBK]							
	<table border="1"> <thead> <tr> <th>Setting range</th> <th>Unit</th> <th>Standard value</th> </tr> </thead> <tbody> <tr> <td>-100.0 to 100.0</td> <td>%</td> <td>0.0</td> </tr> </tbody> </table>	Setting range	Unit	Standard value	-100.0 to 100.0	%	0.0	Compensation function to make the velocity loop stable. Multiply this gain with the detected acceleration to compensate torque command. Setting unit is 0.1%.
Setting range	Unit	Standard value						
-100.0 to 100.0	%	0.0						
18	Acceleration Feedback Filter [AFBFIL]							
	<table border="1"> <thead> <tr> <th>Setting range</th> <th>Unit</th> <th>Standard value</th> </tr> </thead> <tbody> <tr> <td>1 to 2000</td> <td>Hz</td> <td>500</td> </tr> </tbody> </table>	Setting range	Unit	Standard value	1 to 2000	Hz	500	Parameter to put primary low pass filter to acceleration feedback compensation. Sets the cut-off frequency. Filter is disabled with the set value of 2000Hz.
Setting range	Unit	Standard value						
1 to 2000	Hz	500						
20	Torque Command Filter 1 [TCFIL1]							
	<table border="1"> <thead> <tr> <th>Setting range</th> <th>Unit</th> <th>Standard value</th> </tr> </thead> <tbody> <tr> <td>1 to 2000</td> <td>Hz</td> <td>600</td> </tr> </tbody> </table>	Setting range	Unit	Standard value	1 to 2000	Hz	600	Parameter to put low pass filter to torque command. Sets the cut-off frequency. When auto-tuning result saving is executed, the tuning result is automatically saved in this parameter.
Setting range	Unit	Standard value						
1 to 2000	Hz	600						
21	Torque Command Filter Order [TCFILOR]							
	<table border="1"> <thead> <tr> <th>Setting range</th> <th>Unit</th> <th>Standard value</th> </tr> </thead> <tbody> <tr> <td>1 to 3</td> <td>Order</td> <td>2</td> </tr> </tbody> </table>	Setting range	Unit	Standard value	1 to 3	Order	2	Parameter to set ordinal number of torque command filter.
Setting range	Unit	Standard value						
1 to 3	Order	2						

5.Parameter

[Parameter setting value [Group2]]

■ General parameter Group 2

[vibration suppressing control/ notch filter/ disturbance observer settings]

Page	Contents						
00	Vibration Suppressor Frequency 1 [SUPFRQ1]						
	<table border="1"> <thead> <tr> <th>Setting range</th> <th>Unit</th> <th>Standard value</th> </tr> </thead> <tbody> <tr> <td>5 to 500</td> <td>Hz</td> <td>500</td> </tr> </tbody> </table>	Setting range	Unit	Standard value	5 to 500	Hz	500
Setting range	Unit	Standard value					
5 to 500	Hz	500					
01	Vibration Suppressor Level Selection [SUPLV]						
	<table border="1"> <thead> <tr> <th>Setting range</th> <th>Unit</th> <th>Standard value</th> </tr> </thead> <tbody> <tr> <td>00 to 03</td> <td>-</td> <td>00</td> </tr> </tbody> </table>	Setting range	Unit	Standard value	00 to 03	-	00
Setting range	Unit	Standard value					
00 to 03	-	00					
10	Velocity Command,Notch Filter [VCNFIL]						
	<table border="1"> <thead> <tr> <th>Setting range</th> <th>Unit</th> <th>Standard value</th> </tr> </thead> <tbody> <tr> <td>50 to 500</td> <td>Hz</td> <td>500</td> </tr> </tbody> </table>	Setting range	Unit	Standard value	50 to 500	Hz	500
Setting range	Unit	Standard value					
50 to 500	Hz	500					
<p style="text-align: center;">Resonant frequency f_n</p>							
20	Torque Command,Notch Filter A [TCNFILA]						
	<table border="1"> <thead> <tr> <th>Setting range</th> <th>Unit</th> <th>Standard value</th> </tr> </thead> <tbody> <tr> <td>100 to 2000</td> <td>Hz</td> <td>2000</td> </tr> </tbody> </table>	Setting range	Unit	Standard value	100 to 2000	Hz	2000
Setting range	Unit	Standard value					
100 to 2000	Hz	2000					

5.Parameter

[Parameter setting value [Group2]]

21	TCNFILA, Low Frequency Phase Delay Improvement [TCNFPA]			<p>Parameter to improve phase delay at lower frequency than resonant frequency of torque command notch filter A. The larger the value is, the greater the effect is. Same characteristics as the standard notch filter with the set value of 0.</p>				
	<table border="1"> <thead> <tr> <th>Setting range</th> <th>Unit</th> <th>Standard value</th> </tr> </thead> <tbody> <tr> <td>00 to 02</td> <td>-</td> <td>00</td> </tr> </tbody> </table>	Setting range	Unit		Standard value	00 to 02	-	00
Setting range	Unit	Standard value						
00 to 02	-	00						
22	Torque Command,Notch Filter B [TCNFILB]			<p>Parameter to set notch filter to torque command. Sets the resonant frequency. Inside the servo amplifier, the resonant frequency is treated by 10HzUnit. Even when set by 1HzUnit, operations do not change. Filter is disabled with the set value of 2000Hz.</p>				
	<table border="1"> <thead> <tr> <th>Setting range</th> <th>Unit</th> <th>Standard value</th> </tr> </thead> <tbody> <tr> <td>100 to 2000</td> <td>Hz</td> <td>2000</td> </tr> </tbody> </table>	Setting range	Unit		Standard value	100 to 2000	Hz	2000
Setting range	Unit	Standard value						
100 to 2000	Hz	2000						
23	TCNFILB, Depth Selection [TCNFDB]			<p>Parameter to set the depth of torque command notch filter B. The larger the value is, the shallower.</p>				
	<table border="1"> <thead> <tr> <th>Setting range</th> <th>Unit</th> <th>Standard value</th> </tr> </thead> <tbody> <tr> <td>00 to 03</td> <td>-</td> <td>00</td> </tr> </tbody> </table>	Setting range	Unit		Standard value	00 to 03	-	00
Setting range	Unit	Standard value						
00 to 03	-	00						
24	Torque Command, Notch Filter C [TCNFILC]			<p>Parameter to set notch filter to torque command. Sets the resonant frequency. Inside the servo amplifier, the resonant frequency is treated by 10HzUnit. Even when set by 1HzUnit, operations do not change. Filter is disabled with the set value of 2000Hz.</p>				
	<table border="1"> <thead> <tr> <th>Setting range</th> <th>Unit</th> <th>Standard value</th> </tr> </thead> <tbody> <tr> <td>100 to 2000</td> <td>Hz</td> <td>2000</td> </tr> </tbody> </table>	Setting range	Unit		Standard value	100 to 2000	Hz	2000
Setting range	Unit	Standard value						
100 to 2000	Hz	2000						
25	TCNFILC, Depth Selection [TCNFDC]			<p>Parameter to set the depth of torque command notch filter C. The larger the value is, the shallower.</p>				
	<table border="1"> <thead> <tr> <th>Setting range</th> <th>Unit</th> <th>Standard value</th> </tr> </thead> <tbody> <tr> <td>00 to 03</td> <td>-</td> <td>00</td> </tr> </tbody> </table>	Setting range	Unit		Standard value	00 to 03	-	00
Setting range	Unit	Standard value						
00 to 03	-	00						
26	Torque Command,Notch FilterD [TCNFILD]			<p>Parameter to set notch filter to torque command. Sets the resonant frequency. Inside the servo amplifier, the resonant frequency is treated by 10HzUnit. Even when set by 1HzUnit, operations do not change. Filter is disabled with the set value of 2000Hz.</p>				
	<table border="1"> <thead> <tr> <th>Setting range</th> <th>Unit</th> <th>Standard value</th> </tr> </thead> <tbody> <tr> <td>100 to 2000</td> <td>Hz</td> <td>2000</td> </tr> </tbody> </table>	Setting range	Unit		Standard value	100 to 2000	Hz	2000
Setting range	Unit	Standard value						
100 to 2000	Hz	2000						

5.Parameter

[Parameter setting value [Group2]]

Page	Contents												
27	TCNFILd, Depth Selection [TCNFDD]												
	<table border="1"> <thead> <tr> <th>Setting range</th> <th>Unit</th> <th>Standard value</th> </tr> </thead> <tbody> <tr> <td>00 to 03</td> <td>-</td> <td>00</td> </tr> </tbody> </table>	Setting range	Unit	Standard value	00 to 03	-	00	Parameter to set the depth of torque command notch filter D. The greater the value is, the shallower the depth will be.					
Setting range	Unit	Standard value											
00 to 03	-	00											
<p style="text-align: center;">Resonant frequency f_n</p>													
30	Observer characteristic [OBCHA]												
	<table border="1"> <thead> <tr> <th>Setting range</th> <th>Unit</th> <th>Standard value</th> </tr> </thead> <tbody> <tr> <td>00 to 01</td> <td>-</td> <td>00: Low</td> </tr> </tbody> </table>	Setting range	Unit	Standard value	00 to 01	-	00: Low	Selects the observer characteristics. <table border="1" style="margin-left: 20px;"> <thead> <tr> <th>Selection</th> <th>Contents</th> </tr> </thead> <tbody> <tr> <td>00: Low</td> <td>For Low Cycle</td> </tr> <tr> <td>01: Middle</td> <td>For Middle Cycle</td> </tr> </tbody> </table>	Selection	Contents	00: Low	For Low Cycle	01: Middle
Setting range	Unit	Standard value											
00 to 01	-	00: Low											
Selection	Contents												
00: Low	For Low Cycle												
01: Middle	For Middle Cycle												
31	Observer Compensation Gain [OBG]												
	<table border="1"> <thead> <tr> <th>Setting range</th> <th>Unit</th> <th>Standard value</th> </tr> </thead> <tbody> <tr> <td>0 to 100</td> <td>%</td> <td>0</td> </tr> </tbody> </table>	Setting range	Unit	Standard value	0 to 100	%	0	Observer compensation gain. The larger the value is, the higher the suppression characteristics will be. However, if this is too large, oscillation may sometimes occur.					
Setting range	Unit	Standard value											
0 to 100	%	0											
32	Observer Output, Low Pass Filter [OBLPF]												
	<table border="1"> <thead> <tr> <th>Setting range</th> <th>Unit</th> <th>Standard value</th> </tr> </thead> <tbody> <tr> <td>1 to 2000</td> <td>Hz</td> <td>50</td> </tr> </tbody> </table>	Setting range	Unit	Standard value	1 to 2000	Hz	50	Sets the cut off frequency of observer output low pass filter. Filter is disabled with the set value of 2000Hz. When the observer characteristics are "01: Middle (For Middle Cycle)", the function is disabled.					
Setting range	Unit	Standard value											
1 to 2000	Hz	50											
33	Observer Output, Notch Filter [OBNFIL]												
	<table border="1"> <thead> <tr> <th>Setting range</th> <th>Unit</th> <th>Standard value</th> </tr> </thead> <tbody> <tr> <td>100 to 2000</td> <td>Hz</td> <td>2000</td> </tr> </tbody> </table>	Setting range	Unit	Standard value	100 to 2000	Hz	2000	Sets the resonant frequency of observer output notch filter. Inside the servo amplifier, the resonant frequency is treated by 10HzUnit. Even when set by 1HzUnit, operations do not change. Filter is disabled with the set value of 2000Hz.					
Setting range	Unit	Standard value											
100 to 2000	Hz	2000											



5.Parameter [Parameter setting value [Group4][Group8]]

■ General parameter Group 3

[Gain switching control/ vibration suppressing frequency switching settings]

Page	Contents							
00	Position Loop Proportional Gain 2 [KP2]							
	<table border="1"> <thead> <tr> <th>Setting range</th> <th>Unit</th> <th>Standard value</th> </tr> </thead> <tbody> <tr> <td>1 to 3000</td> <td>1/s</td> <td>30</td> </tr> </tbody> </table>	Setting range	Unit	Standard value	1 to 3000	1/s	30	Proportional gain for position controller.
Setting range	Unit	Standard value						
1 to 3000	1/s	30						
01	Position Loop Integral Time Constant 2 [TPI2]							
	<table border="1"> <thead> <tr> <th>Setting range</th> <th>Unit</th> <th>Standard value</th> </tr> </thead> <tbody> <tr> <td>0.5 to 1000.0</td> <td>ms</td> <td>1000.0</td> </tr> </tbody> </table>	Setting range	Unit	Standard value	0.5 to 1000.0	ms	1000.0	Integral time constant for position controller. Integral term is disabled (proportional control) with the set value of 1000.0ms. ⚠ Cannot be used when the position loop proportional control switching function is enabled.
Setting range	Unit	Standard value						
0.5 to 1000.0	ms	1000.0						
02	Velocity Loop Proportional Gain 2 [KVP2]							
	<table border="1"> <thead> <tr> <th>Setting range</th> <th>Unit</th> <th>Standard value</th> </tr> </thead> <tbody> <tr> <td>1 to 2000</td> <td>Hz</td> <td>50</td> </tr> </tbody> </table>	Setting range	Unit	Standard value	1 to 2000	Hz	50	Proportional gain for velocity controller. When load inertia is the one set by load inertia moment ratio (load mass ratio) 2, the response is this set value.
Setting range	Unit	Standard value						
1 to 2000	Hz	50						
03	Velocity Loop Integral Time Constant 2 [TVI2]							
	<table border="1"> <thead> <tr> <th>Setting range</th> <th>Unit</th> <th>Standard value</th> </tr> </thead> <tbody> <tr> <td>0.5 to 1000.0</td> <td>ms</td> <td>20.0</td> </tr> </tbody> </table>	Setting range	Unit	Standard value	0.5 to 1000.0	ms	20.0	Integral time constant for velocity controller. Enabled when velocity loop proportional control switching function is disabled. Integral term is disabled (proportional control) with the set value of 1000.0ms.
Setting range	Unit	Standard value						
0.5 to 1000.0	ms	20.0						
04	Load Inertia Ratio (Load Mass Ratio) 2 [JRAT2]							
	<table border="1"> <thead> <tr> <th>Setting range</th> <th>Unit</th> <th>Standard value</th> </tr> </thead> <tbody> <tr> <td>0 to 15000</td> <td>%</td> <td>100</td> </tr> </tbody> </table>	Setting range	Unit	Standard value	0 to 15000	%	100	Sets the inertia moment of load device to the motor inertia moment. Set value=JL/JM×100% JL: Load inertia moment JM: Motor inertia moment
Setting range	Unit	Standard value						
0 to 15000	%	100						
05	Torque Command Filter 2 [TCFIL2]							
	<table border="1"> <thead> <tr> <th>Setting range</th> <th>Unit</th> <th>Standard value</th> </tr> </thead> <tbody> <tr> <td>1 to 2000</td> <td>Hz</td> <td>600</td> </tr> </tbody> </table>	Setting range	Unit	Standard value	1 to 2000	Hz	600	Parameter to set low pass filter to torque command. Sets the cut off frequency.
Setting range	Unit	Standard value						
1 to 2000	Hz	600						
10	Position Loop Proportional Gain 3 [KP3]							
	<table border="1"> <thead> <tr> <th>Setting range</th> <th>Unit</th> <th>Standard value</th> </tr> </thead> <tbody> <tr> <td>1 to 3000</td> <td>1/s</td> <td>30</td> </tr> </tbody> </table>	Setting range	Unit	Standard value	1 to 3000	1/s	30	Proportional gain for position controller.
Setting range	Unit	Standard value						
1 to 3000	1/s	30						
11	Position Loop Integral Time Constant 3 [TPI3]							
	<table border="1"> <thead> <tr> <th>Setting range</th> <th>Unit</th> <th>Standard value</th> </tr> </thead> <tbody> <tr> <td>0.5 to 1000.0</td> <td>ms</td> <td>1000.0</td> </tr> </tbody> </table>	Setting range	Unit	Standard value	0.5 to 1000.0	ms	1000.0	Integral time constant for position controller. Integral term is disabled (proportional control) with the set value of 1000.0ms. ⚠ Cannot be used when position loop proportional control switching function is enabled.
Setting range	Unit	Standard value						
0.5 to 1000.0	ms	1000.0						
12	Velocity Loop Proportional Gain 3 [KVP3]							
	<table border="1"> <thead> <tr> <th>Setting range</th> <th>Unit</th> <th>Standard value</th> </tr> </thead> <tbody> <tr> <td>1 to 2000</td> <td>Hz</td> <td>50</td> </tr> </tbody> </table>	Setting range	Unit	Standard value	1 to 2000	Hz	50	Proportional gain for velocity controller. When load inertia is the one set by load inertia moment ratio (load mass ratio) 2, the response is this set value.
Setting range	Unit	Standard value						
1 to 2000	Hz	50						
13	Velocity Loop Integral Time Constant 3 [TVI3]							
	<table border="1"> <thead> <tr> <th>Setting range</th> <th>Unit</th> <th>Standard value</th> </tr> </thead> <tbody> <tr> <td>0.5 to 1000.0</td> <td>ms</td> <td>20.0</td> </tr> </tbody> </table>	Setting range	Unit	Standard value	0.5 to 1000.0	ms	20.0	Integral time constant for velocity controller. This setting is enabled when velocity loop proportional control switching function is disabled. Integral term is disabled (proportional control) with the set value of 1000.0ms.
Setting range	Unit	Standard value						
0.5 to 1000.0	ms	20.0						
14	Load Inertia Ratio (Load Mass Ratio) 3 [JRAT3]							
	<table border="1"> <thead> <tr> <th>Setting range</th> <th>Unit</th> <th>Standard value</th> </tr> </thead> <tbody> <tr> <td>0 to 15000</td> <td>%</td> <td>100</td> </tr> </tbody> </table>	Setting range	Unit	Standard value	0 to 15000	%	100	Sets the inertia moment of load device to the motor inertia moment. Set value=JL/JM×100% JL: Load inertia moment JM: Motor inertia moment
Setting range	Unit	Standard value						
0 to 15000	%	100						
15	Torque Command Filter 3 [TCFIL3]							
	<table border="1"> <thead> <tr> <th>Setting range</th> <th>Unit</th> <th>Standard value</th> </tr> </thead> <tbody> <tr> <td>1 to 2000</td> <td>Hz</td> <td>600</td> </tr> </tbody> </table>	Setting range	Unit	Standard value	1 to 2000	Hz	600	Parameter to set low pass filter to torque command. Sets the cut off frequency.
Setting range	Unit	Standard value						
1 to 2000	Hz	600						

5.Parameter [Parameter setting value [Group4][Group8]]

Page	Contents							
20	Position Loop Proportional Gain 4 [KP4]							
	<table border="1"> <thead> <tr> <th>Setting range</th> <th>Unit</th> <th>Standard value</th> </tr> </thead> <tbody> <tr> <td>1 to 3000</td> <td>1/s</td> <td>30</td> </tr> </tbody> </table>	Setting range	Unit	Standard value	1 to 3000	1/s	30	Proportional gain for position controller.
Setting range	Unit	Standard value						
1 to 3000	1/s	30						
21	Position Loop Integral Time Constant 4 [TP4]							
	<table border="1"> <thead> <tr> <th>Setting range</th> <th>Unit</th> <th>Standard value</th> </tr> </thead> <tbody> <tr> <td>0.5 to 1000.0</td> <td>ms</td> <td>1000.0</td> </tr> </tbody> </table>	Setting range	Unit	Standard value	0.5 to 1000.0	ms	1000.0	Integral time constant for position controller. Integral term is disabled (proportional control) with the set value of 1000.0ms. Cannot be used when position loop proportional control switching function is enabled.
Setting range	Unit	Standard value						
0.5 to 1000.0	ms	1000.0						
22	Velocity Loop Proportional Gain 4 [KVP4]							
	<table border="1"> <thead> <tr> <th>Setting range</th> <th>Unit</th> <th>Standard value</th> </tr> </thead> <tbody> <tr> <td>1 to 2000</td> <td>Hz</td> <td>50</td> </tr> </tbody> </table>	Setting range	Unit	Standard value	1 to 2000	Hz	50	Proportional gain for velocity controller. When load inertia is the one set by load inertia moment ratio (load mass ratio) 2, the response is this set value.
Setting range	Unit	Standard value						
1 to 2000	Hz	50						
23	Velocity Loop Integral Time Constant 4 [TV4]							
	<table border="1"> <thead> <tr> <th>Setting range</th> <th>Unit</th> <th>Standard value</th> </tr> </thead> <tbody> <tr> <td>0.5 to 1000.0</td> <td>ms</td> <td>20.0</td> </tr> </tbody> </table>	Setting range	Unit	Standard value	0.5 to 1000.0	ms	20.0	Integral time constant for velocity controller. This setting is enabled when velocity loop proportional control switching function is disabled. Integral term is disabled (proportional control) with the set value of 1000.0ms.
Setting range	Unit	Standard value						
0.5 to 1000.0	ms	20.0						
24	Load Inertia Ratio (Load Mass Ratio) 4 [JRAT4]							
	<table border="1"> <thead> <tr> <th>Setting range</th> <th>Unit</th> <th>Standard value</th> </tr> </thead> <tbody> <tr> <td>0 to 15000</td> <td>%</td> <td>100</td> </tr> </tbody> </table>	Setting range	Unit	Standard value	0 to 15000	%	100	Sets the inertia moment of load device to the motor inertia moment. Set value=JL/JM×100% JL: Load inertia moment JM: Motor inertia moment
Setting range	Unit	Standard value						
0 to 15000	%	100						
25	Torque Command Filter 4 [TCFIL4]							
	<table border="1"> <thead> <tr> <th>Setting range</th> <th>Unit</th> <th>Standard value</th> </tr> </thead> <tbody> <tr> <td>1 to 2000</td> <td>Hz</td> <td>600</td> </tr> </tbody> </table>	Setting range	Unit	Standard value	1 to 2000	Hz	600	Parameter to set low pass filter to torque command. Sets the cut off frequency.
Setting range	Unit	Standard value						
1 to 2000	Hz	600						
30	Low Pass Filter of Gain Switching [GCFIL]							
	<table border="1"> <thead> <tr> <th>Setting range</th> <th>Unit</th> <th>Standard value</th> </tr> </thead> <tbody> <tr> <td>0 to 100</td> <td>ms</td> <td>0</td> </tr> </tbody> </table>	Setting range	Unit	Standard value	0 to 100	ms	0	Parameter to set time constant for gain switching. The larger the value is, the gentler the switching is.
Setting range	Unit	Standard value						
0 to 100	ms	0						
40	Vibration Suppressor Frequency 2 [SUPFRQ2]							
	<table border="1"> <thead> <tr> <th>Setting range</th> <th>Unit</th> <th>Standard value</th> </tr> </thead> <tbody> <tr> <td>5 to 500</td> <td>Hz</td> <td>500</td> </tr> </tbody> </table>	Setting range	Unit	Standard value	5 to 500	Hz	500	Parameter to set the frequency of vibration suppressing vibration. In the servo amplifier, the vibration suppressing frequency from 5 to 99Hz is treated by 1Hz unit, and from 100 to 500Hz is by 10Hz unit. Operations do not change if set by lower unit than these. Vibration suppressing control is disabled when the set value is 500Hz.  Change this while the motor stops.
Setting range	Unit	Standard value						
5 to 500	Hz	500						
41	Vibration Suppressor Frequency 3 [SUPFRQ3]							
	<table border="1"> <thead> <tr> <th>Setting range</th> <th>Unit</th> <th>Standard value</th> </tr> </thead> <tbody> <tr> <td>5 to 500</td> <td>Hz</td> <td>500</td> </tr> </tbody> </table>	Setting range	Unit	Standard value	5 to 500	Hz	500	Parameter to set the frequency of vibration suppressing vibration. In the servo amplifier, the vibration suppressing frequency from 5 to 99Hz is treated by 1H unit, and from 100 to 500Hz is by 10Hz unit. Operations do not change if set by lower unit than these. Vibration suppressing control is disabled when the set value is 500Hz.  Change this while the motor stops.
Setting range	Unit	Standard value						
5 to 500	Hz	500						
42	Vibration Suppressor Frequency 4 [SUPFRQ4]							
	<table border="1"> <thead> <tr> <th>Setting range</th> <th>Unit</th> <th>Standard value</th> </tr> </thead> <tbody> <tr> <td>5 to 500</td> <td>Hz</td> <td>500</td> </tr> </tbody> </table>	Setting range	Unit	Standard value	5 to 500	Hz	500	Parameter to set the frequency of vibration suppressing vibration. In the servo amplifier, the vibration suppressing frequency from 5 to 99Hz is treated by 1H unit, and from 100 to 500Hz is by 10Hz unit. Operations do not change if set by lower unit than these. Vibration suppressing control is disabled when the set value is 500Hz.  Change this while the motor stops.
Setting range	Unit	Standard value						
5 to 500	Hz	500						

5.Parameter [Parameter setting value [Group4][Group8]]

■ General parameter Group 4 [High setting control settings]

Page	Contents							
00	Command Velocity, Low Pass Filter [CVFIL]							
	<table border="1"> <thead> <tr> <th>Setting range</th> <th>Unit</th> <th>Standard value</th> </tr> </thead> <tbody> <tr> <td>1 to 2000</td> <td>Hz</td> <td>1000</td> </tr> </tbody> </table>	Setting range	Unit	Standard value	1 to 2000	Hz	1000	Sets the cut off frequency of low pass filter, when command velocity is calculated. When the position command resolution is low, lower the cut off frequency. Filter is disabled when the set value is 2000Hz.
Setting range	Unit	Standard value						
1 to 2000	Hz	1000						
01	Command Velocity Threshold [CVTH]							
	<table border="1"> <thead> <tr> <th>Setting range</th> <th>Unit</th> <th>Standard value</th> </tr> </thead> <tbody> <tr> <td>0 to 65535</td> <td>min⁻¹</td> <td>20</td> </tr> </tbody> </table>	Setting range	Unit	Standard value	0 to 65535	min ⁻¹	20	When the command velocity calculated from position command is larger than this threshold, acceleration or deceleration compensation will be performed.
Setting range	Unit	Standard value						
0 to 65535	min ⁻¹	20						
02	Acceleration Compensation [ACCCO]							
	<table border="1"> <thead> <tr> <th>Setting range</th> <th>Unit</th> <th>Standard value</th> </tr> </thead> <tbody> <tr> <td>-9999 to +9999</td> <td>×50 Pulse</td> <td>0</td> </tr> </tbody> </table>	Setting range	Unit	Standard value	-9999 to +9999	×50 Pulse	0	Compensation at acceleration.
Setting range	Unit	Standard value						
-9999 to +9999	×50 Pulse	0						
03	Deceleration Compensation [DECCO]							
	<table border="1"> <thead> <tr> <th>Setting range</th> <th>Unit</th> <th>Standard value</th> </tr> </thead> <tbody> <tr> <td>-9999 to +9999</td> <td>×50 Pulse</td> <td>0</td> </tr> </tbody> </table>	Setting range	Unit	Standard value	-9999 to +9999	×50 Pulse	0	Compensation at deceleration.
Setting range	Unit	Standard value						
-9999 to +9999	×50 Pulse	0						

■ General parameter Group 8 [Settings for control system]

Page	Contents																													
00	Position and Velocity Torque Command Input Polarity [CMDPOL]																													
	<table border="1"> <thead> <tr> <th>Setting range</th> <th>Unit</th> <th>Standard value</th> </tr> </thead> <tbody> <tr> <td>00 to 07</td> <td>-</td> <td>00:_PC+_VC+_TC+</td> </tr> </tbody> </table>	Setting range	Unit	Standard value	00 to 07	-	00:_PC+_VC+_TC+	Select the command polarity from the contents blow.																						
	Setting range	Unit	Standard value																											
	00 to 07	-	00:_PC+_VC+_TC+																											
	<table border="1"> <thead> <tr> <th>Input command</th> <th>Command polarity</th> <th>Rotation direction</th> <th>Selection</th> </tr> </thead> <tbody> <tr> <td>Position command</td> <td>+</td> <td>Forward</td> <td rowspan="3">00:_PC+_VC+_TC+</td> </tr> <tr> <td>Velocity command</td> <td>+</td> <td>Forward</td> </tr> <tr> <td>Torque command</td> <td>+</td> <td>Forward</td> </tr> </tbody> </table>	Input command	Command polarity	Rotation direction	Selection	Position command	+	Forward	00:_PC+_VC+_TC+	Velocity command	+	Forward	Torque command	+	Forward	<table border="1"> <thead> <tr> <th>Input command</th> <th>Command polarity</th> <th>Rotation direction</th> <th>Selection</th> </tr> </thead> <tbody> <tr> <td>Position command</td> <td>+</td> <td>Reverse</td> <td rowspan="3">04:_PC-_VC+_TC+</td> </tr> <tr> <td>Velocity command</td> <td>+</td> <td>Forward</td> </tr> <tr> <td>Torque command</td> <td>+</td> <td>Forward</td> </tr> </tbody> </table>	Input command	Command polarity	Rotation direction	Selection	Position command	+	Reverse	04:_PC-_VC+_TC+	Velocity command	+	Forward	Torque command	+	Forward
	Input command	Command polarity	Rotation direction	Selection																										
	Position command	+	Forward	00:_PC+_VC+_TC+																										
	Velocity command	+	Forward																											
	Torque command	+	Forward																											
	Input command	Command polarity	Rotation direction	Selection																										
Position command	+	Reverse	04:_PC-_VC+_TC+																											
Velocity command	+	Forward																												
Torque command	+	Forward																												
<table border="1"> <thead> <tr> <th>Input command</th> <th>Command polarity</th> <th>Rotation direction</th> <th>Selection</th> </tr> </thead> <tbody> <tr> <td>Position</td> <td>+</td> <td>Forward</td> <td rowspan="3">01:_PC+_VC+_TC-</td> </tr> <tr> <td>Velocity</td> <td>+</td> <td>Forward</td> </tr> <tr> <td>Torque</td> <td>+</td> <td>Reverse</td> </tr> </tbody> </table>	Input command	Command polarity	Rotation direction	Selection	Position	+	Forward	01:_PC+_VC+_TC-	Velocity	+	Forward	Torque	+	Reverse	<table border="1"> <thead> <tr> <th>Input command</th> <th>Command polarity</th> <th>Rotation direction</th> <th>Selection</th> </tr> </thead> <tbody> <tr> <td>V velocity</td> <td>+</td> <td>Forward</td> <td rowspan="2">05:_PC-_VC+_TC-</td> </tr> <tr> <td>Torque</td> <td>+</td> <td>Reverse</td> </tr> </tbody> </table>	Input command	Command polarity	Rotation direction	Selection	V velocity	+	Forward	05:_PC-_VC+_TC-	Torque	+	Reverse				
Input command	Command polarity	Rotation direction	Selection																											
Position	+	Forward	01:_PC+_VC+_TC-																											
Velocity	+	Forward																												
Torque	+	Reverse																												
Input command	Command polarity	Rotation direction	Selection																											
V velocity	+	Forward	05:_PC-_VC+_TC-																											
Torque	+	Reverse																												
<table border="1"> <thead> <tr> <th>Input command</th> <th>Command polarity</th> <th>Rotation direction</th> <th>Selection</th> </tr> </thead> <tbody> <tr> <td>Position</td> <td>+</td> <td>Forward</td> <td rowspan="3">02:_PC+_VC-_TC+</td> </tr> <tr> <td>Velocity</td> <td>+</td> <td>Reverse</td> </tr> <tr> <td>Torque</td> <td>+</td> <td>Forward</td> </tr> </tbody> </table>	Input command	Command polarity	Rotation direction	Selection	Position	+	Forward	02:_PC+_VC-_TC+	Velocity	+	Reverse	Torque	+	Forward	<table border="1"> <thead> <tr> <th>Input command</th> <th>Command polarity</th> <th>Rotation direction</th> <th>Selection</th> </tr> </thead> <tbody> <tr> <td>Position</td> <td>+</td> <td>Reverse</td> <td rowspan="3">06:_PC-_VC-_TC+</td> </tr> <tr> <td>Velocity</td> <td>+</td> <td>Reverse</td> </tr> <tr> <td>Torque</td> <td>+</td> <td>Forward</td> </tr> </tbody> </table>	Input command	Command polarity	Rotation direction	Selection	Position	+	Reverse	06:_PC-_VC-_TC+	Velocity	+	Reverse	Torque	+	Forward	
Input command	Command polarity	Rotation direction	Selection																											
Position	+	Forward	02:_PC+_VC-_TC+																											
Velocity	+	Reverse																												
Torque	+	Forward																												
Input command	Command polarity	Rotation direction	Selection																											
Position	+	Reverse	06:_PC-_VC-_TC+																											
Velocity	+	Reverse																												
Torque	+	Forward																												
<table border="1"> <thead> <tr> <th>Input command</th> <th>Command polarity</th> <th>Rotation direction</th> <th>Selection</th> </tr> </thead> <tbody> <tr> <td>Position</td> <td>+</td> <td>Forward</td> <td rowspan="3">03:_PC+_VC-_TC-</td> </tr> <tr> <td>Velocity</td> <td>+</td> <td>Reverse</td> </tr> <tr> <td>Torque</td> <td>+</td> <td>Reverse</td> </tr> </tbody> </table>	Input command	Command polarity	Rotation direction	Selection	Position	+	Forward	03:_PC+_VC-_TC-	Velocity	+	Reverse	Torque	+	Reverse	<table border="1"> <thead> <tr> <th>Input command</th> <th>Command polarity</th> <th>Rotation direction</th> <th>Selection</th> </tr> </thead> <tbody> <tr> <td>Position</td> <td>+</td> <td>Reverse</td> <td rowspan="3">07:_PC-_VC-_TC-</td> </tr> <tr> <td>Velocity</td> <td>+</td> <td>Reverse</td> </tr> <tr> <td>Torque</td> <td>+</td> <td>Reverse</td> </tr> </tbody> </table>	Input command	Command polarity	Rotation direction	Selection	Position	+	Reverse	07:_PC-_VC-_TC-	Velocity	+	Reverse	Torque	+	Reverse	
Input command	Command polarity	Rotation direction	Selection																											
Position	+	Forward	03:_PC+_VC-_TC-																											
Velocity	+	Reverse																												
Torque	+	Reverse																												
Input command	Command polarity	Rotation direction	Selection																											
Position	+	Reverse	07:_PC-_VC-_TC-																											
Velocity	+	Reverse																												
Torque	+	Reverse																												
01	Analog Input Dead Band [VC/TC-DB]																													
	<table border="1"> <thead> <tr> <th>Setting range</th> <th>Unit</th> <th>Standard value</th> </tr> </thead> <tbody> <tr> <td>00 to 01</td> <td>-</td> <td>00:_Disabled</td> </tr> </tbody> </table>	Setting range	Unit	Standard value	00 to 01	-	00:_Disabled	Select enabled/disabled of analog input dead zone.																						
Setting range	Unit	Standard value																												
00 to 01	-	00:_Disabled																												
			<table border="1"> <thead> <tr> <th>Selection</th> <th>Contents</th> </tr> </thead> <tbody> <tr> <td>00:_Disabled</td> <td>Disabled</td> </tr> <tr> <td>01:_Enabled</td> <td>Enabled</td> </tr> </tbody> </table>	Selection	Contents	00:_Disabled	Disabled	01:_Enabled	Enabled																					
Selection	Contents																													
00:_Disabled	Disabled																													
01:_Enabled	Enabled																													

5.Parameter

[Parameter setting value [Group8]]

Page	Contents																			
02	Analog Input Dead Band Width [VCZDAT] <table border="1"> <thead> <tr> <th>Setting range</th> <th>Unit</th> <th>Standard value</th> </tr> </thead> <tbody> <tr> <td>0.0 to 6553.5</td> <td>mV</td> <td>0.0</td> </tr> </tbody> </table>		Setting range	Unit	Standard value	0.0 to 6553.5	mV	0.0												
Setting range	Unit	Standard value																		
0.0 to 6553.5	mV	0.0																		
	Sets the width of Analog Input Dead Band. Consider that the analog input pressure within this limits is 0V. It is effective to both velocity and the torque commands. These value become effective if Analog Input Dead Band setting is valid.																			
11	Position Command Pulse, Form Selection [PCPTYP] <table border="1"> <thead> <tr> <th>Setting range</th> <th>Unit</th> <th>Standard value</th> </tr> </thead> <tbody> <tr> <td>00 to 02</td> <td>-</td> <td>00: F-PC_R-PC</td> </tr> </tbody> </table>		Setting range	Unit	Standard value	00 to 02	-	00: F-PC_R-PC												
Setting range	Unit	Standard value																		
00 to 02	-	00: F-PC_R-PC																		
	Select the position command pulse type from the contents below. <table border="1"> <thead> <tr> <th>Selection</th> <th>Contents</th> </tr> </thead> <tbody> <tr> <td>00: F-PC_R-PC</td> <td>Positive Move Pulse + Negative Move Pulse</td> </tr> <tr> <td>01: 2PhasePulse</td> <td>Two-Phase Pulse Train of 90 Degrees Phase Difference</td> </tr> <tr> <td>02: CODE_PC</td> <td>Code + Pulse Train</td> </tr> </tbody> </table> <p> The set value is enabled after control power is turned ON again.</p>		Selection	Contents	00: F-PC_R-PC	Positive Move Pulse + Negative Move Pulse	01: 2PhasePulse	Two-Phase Pulse Train of 90 Degrees Phase Difference	02: CODE_PC	Code + Pulse Train										
Selection	Contents																			
00: F-PC_R-PC	Positive Move Pulse + Negative Move Pulse																			
01: 2PhasePulse	Two-Phase Pulse Train of 90 Degrees Phase Difference																			
02: CODE_PC	Code + Pulse Train																			
12	Position Command Pulse, Count Polarity [PCPPOL] <table border="1"> <thead> <tr> <th>Setting range</th> <th>Unit</th> <th>Standard value</th> </tr> </thead> <tbody> <tr> <td>00 to 03</td> <td>-</td> <td>00: Type1</td> </tr> </tbody> </table>		Setting range	Unit	Standard value	00 to 03	-	00: Type1												
Setting range	Unit	Standard value																		
00 to 03	-	00: Type1																		
	Select the position command pulse count polarity from the contents below. <table border="1"> <thead> <tr> <th>Selection</th> <th>Contents</th> </tr> </thead> <tbody> <tr> <td>00: Type1</td> <td>F-PC/ Count at the Rising Edge : R-PC/ Count at the Rising Edge</td> </tr> <tr> <td>01: Type2</td> <td>F-PC/ Count at the Falling Edge : R-PC/ Count at the Rising Edge</td> </tr> <tr> <td>02: Type3</td> <td>F-PC/ Count at the Rising Edge : R-PC/ Count at the Falling Edge</td> </tr> <tr> <td>03: Type4</td> <td>F-PC/ Count at the Falling Edge : R-PC/ Count at the Falling Edge</td> </tr> </tbody> </table> <p> The set value is enabled after control power is turned ON again.</p>		Selection	Contents	00: Type1	F-PC/ Count at the Rising Edge : R-PC/ Count at the Rising Edge	01: Type2	F-PC/ Count at the Falling Edge : R-PC/ Count at the Rising Edge	02: Type3	F-PC/ Count at the Rising Edge : R-PC/ Count at the Falling Edge	03: Type4	F-PC/ Count at the Falling Edge : R-PC/ Count at the Falling Edge								
Selection	Contents																			
00: Type1	F-PC/ Count at the Rising Edge : R-PC/ Count at the Rising Edge																			
01: Type2	F-PC/ Count at the Falling Edge : R-PC/ Count at the Rising Edge																			
02: Type3	F-PC/ Count at the Rising Edge : R-PC/ Count at the Falling Edge																			
03: Type4	F-PC/ Count at the Falling Edge : R-PC/ Count at the Falling Edge																			
13	Position Command Pulse, Digital Filter [PCPFIL] <table border="1"> <thead> <tr> <th>Setting range</th> <th>Unit</th> <th>Standard value</th> </tr> </thead> <tbody> <tr> <td>00 to 07</td> <td>-</td> <td>00: 834nsec</td> </tr> </tbody> </table>		Setting range	Unit	Standard value	00 to 07	-	00: 834nsec												
Setting range	Unit	Standard value																		
00 to 07	-	00: 834nsec																		
	Select the setting of position command pulse digital filter from the contents below. As timing for command direction, observe the specifications of position command. When the pulse command form is "Two-Phase Pulse Train of 90 Degrees Phase Difference," observe the specifications of position command. <table border="1"> <thead> <tr> <th>Selection</th> <th>Contents</th> </tr> </thead> <tbody> <tr> <td>00: 834nsec</td> <td>Minimum Pulse Width = 834nsec</td> </tr> <tr> <td>01: 250nsec</td> <td>Minimum Pulse Width = 250nsec</td> </tr> <tr> <td>02: 500nsec</td> <td>Minimum Pulse Width = 500nsec</td> </tr> <tr> <td>03: 1.8usec</td> <td>Minimum Pulse Width = 1.8µsec</td> </tr> <tr> <td>04: 3.6usec</td> <td>Minimum Pulse Width = 3.6µsec</td> </tr> <tr> <td>05: 7.2usec</td> <td>Minimum Pulse Width = 7.2µsec</td> </tr> <tr> <td>06: 125nsec</td> <td>Minimum Pulse Width = 125nsec</td> </tr> <tr> <td>07: 83.4nsec</td> <td>Minimum Pulse Width = 83.4nsec</td> </tr> </tbody> </table>		Selection	Contents	00: 834nsec	Minimum Pulse Width = 834nsec	01: 250nsec	Minimum Pulse Width = 250nsec	02: 500nsec	Minimum Pulse Width = 500nsec	03: 1.8usec	Minimum Pulse Width = 1.8µsec	04: 3.6usec	Minimum Pulse Width = 3.6µsec	05: 7.2usec	Minimum Pulse Width = 7.2µsec	06: 125nsec	Minimum Pulse Width = 125nsec	07: 83.4nsec	Minimum Pulse Width = 83.4nsec
Selection	Contents																			
00: 834nsec	Minimum Pulse Width = 834nsec																			
01: 250nsec	Minimum Pulse Width = 250nsec																			
02: 500nsec	Minimum Pulse Width = 500nsec																			
03: 1.8usec	Minimum Pulse Width = 1.8µsec																			
04: 3.6usec	Minimum Pulse Width = 3.6µsec																			
05: 7.2usec	Minimum Pulse Width = 7.2µsec																			
06: 125nsec	Minimum Pulse Width = 125nsec																			
07: 83.4nsec	Minimum Pulse Width = 83.4nsec																			
14	Position Command, Pulse Multiplier [PCPMUL] <table border="1"> <thead> <tr> <th>Setting range</th> <th>Unit</th> <th>Standard value</th> </tr> </thead> <tbody> <tr> <td>1 to 63</td> <td>-</td> <td>1</td> </tr> </tbody> </table>		Setting range	Unit	Standard value	1 to 63	-	1												
Setting range	Unit	Standard value																		
1 to 63	-	1																		
	Parameter to multiply the command pulse by x1 to x63. Values from 1 to 63 are set, which are always enabled.																			
15	Electric Gear Ratio 1 [GER1] <table border="1"> <thead> <tr> <th>Setting range</th> <th>Unit</th> <th>Standard value</th> </tr> </thead> <tbody> <tr> <td>1/32767 to 32767/1</td> <td>-</td> <td>1/1</td> </tr> </tbody> </table>		Setting range	Unit	Standard value	1/32767 to 32767/1	-	1/1												
Setting range	Unit	Standard value																		
1/32767 to 32767/1	-	1/1																		
16	Electric Gear Ratio 2 [GER2] <table border="1"> <thead> <tr> <th>Setting range</th> <th>Unit</th> <th>Standard value</th> </tr> </thead> <tbody> <tr> <td>1/32767 to 32767/1</td> <td>-</td> <td>1/1</td> </tr> </tbody> </table>		Setting range	Unit	Standard value	1/32767 to 32767/1	-	1/1												
Setting range	Unit	Standard value																		
1/32767 to 32767/1	-	1/1																		
	Setting of electronic gear to position command pulse. $f1 \longrightarrow \frac{N (1 \text{ to } 32767)}{D (1 \text{ to } 32767)} \longrightarrow f2 (f2 = f1 \times N/D)$ $1/32767 \leq N/D \leq 32767$																			

5.Parameter

[Parameter setting value [Group8]]

Page	Contents																
17	Positioning method [EDGEPOS]																
	<table border="1"> <thead> <tr> <th>Setting range</th> <th>Unit</th> <th>Standard value</th> </tr> </thead> <tbody> <tr> <td>00 to 01</td> <td>-</td> <td>00: _Pulse _Interval</td> </tr> </tbody> </table>	Setting range	Unit	Standard value	00 to 01	-	00: _Pulse _Interval	Select the encoder pulse positioning from the contents below. <table border="1"> <thead> <tr> <th>Selection</th> <th>Contents</th> </tr> </thead> <tbody> <tr> <td>00: _Pulse _Interval</td> <td>Specify Pulse Interval</td> </tr> <tr> <td>01: _Pulse _Edge</td> <td>Specify Pulse Edge</td> </tr> </tbody> </table> <p> The set value is enabled after control power is turned ON again.</p>	Selection	Contents	00: _Pulse _Interval	Specify Pulse Interval	01: _Pulse _Edge	Specify Pulse Edge			
Setting range	Unit	Standard value															
00 to 01	-	00: _Pulse _Interval															
Selection	Contents																
00: _Pulse _Interval	Specify Pulse Interval																
01: _Pulse _Edge	Specify Pulse Edge																
18	Inposition / Position Deviation Monitor [PDEVMON]																
	<table border="1"> <thead> <tr> <th>Setting range</th> <th>Unit</th> <th>Standard value</th> </tr> </thead> <tbody> <tr> <td>00 to 01</td> <td>-</td> <td>00: _After _Filter</td> </tr> </tbody> </table>	Setting range	Unit	Standard value	00 to 01	-	00: _After _Filter	Select the positioning complete signal (INP) and position deviation monitor from the contents below. <table border="1"> <thead> <tr> <th>Selection</th> <th>Contents</th> </tr> </thead> <tbody> <tr> <td>00: _After _Filter</td> <td>Compare "Position Command Value After Filter Passes by" with "Feedback Value"</td> </tr> <tr> <td>01: _Before _Filter</td> <td>Compare "Position Command Value Before Filter Passes by" with "Feedback Value"</td> </tr> </tbody> </table>	Selection	Contents	00: _After _Filter	Compare "Position Command Value After Filter Passes by" with "Feedback Value"	01: _Before _Filter	Compare "Position Command Value Before Filter Passes by" with "Feedback Value"			
Setting range	Unit	Standard value															
00 to 01	-	00: _After _Filter															
Selection	Contents																
00: _After _Filter	Compare "Position Command Value After Filter Passes by" with "Feedback Value"																
01: _Before _Filter	Compare "Position Command Value Before Filter Passes by" with "Feedback Value"																
19	Deviation Clear Selection [CLR]																
	<table border="1"> <thead> <tr> <th>Setting range</th> <th>Unit</th> <th>Standard value</th> </tr> </thead> <tbody> <tr> <td>00 to 03</td> <td>-</td> <td>00: _Type1</td> </tr> </tbody> </table>	Setting range	Unit	Standard value	00 to 03	-	00: _Type1	Select the position deviation clearing method from the contents below. <table border="1"> <thead> <tr> <th>Selection</th> <th>Contents</th> </tr> </thead> <tbody> <tr> <td>00: _Type1</td> <td>When SERVO-OFF/ Clear Deviation: Deviation Clear Input/ Level Detection During servo OFF, deviation clear is always executed. While deviation clear input is ON, deviation clear is always executed.</td> </tr> <tr> <td>01: _Type2</td> <td>When SERVO-OFF/ Clear Deviation: Deviation Clear Input/ Edge Detection At the edge of OFF→ON of deviation clear input, deviation clear is executed.</td> </tr> <tr> <td>02: _Type3</td> <td>When SERVO-OFF/ Not Clear Deviation: Deviation Clear Input/ Level Detection During servo OFF, deviation clear is not executed. (After servo ON, the motor may operate suddenly.)</td> </tr> <tr> <td>03: _Type4</td> <td>When SERVO-OFF/ Not Clear Deviation: Deviation Clear Input/ Edge Detection During servo OFF, deviation clear is not executed. (After servo ON, the motor may operate suddenly.)</td> </tr> </tbody> </table>	Selection	Contents	00: _Type1	When SERVO-OFF/ Clear Deviation: Deviation Clear Input/ Level Detection During servo OFF, deviation clear is always executed. While deviation clear input is ON, deviation clear is always executed.	01: _Type2	When SERVO-OFF/ Clear Deviation: Deviation Clear Input/ Edge Detection At the edge of OFF→ON of deviation clear input, deviation clear is executed.	02: _Type3	When SERVO-OFF/ Not Clear Deviation: Deviation Clear Input/ Level Detection During servo OFF, deviation clear is not executed. (After servo ON, the motor may operate suddenly.)	03: _Type4
Setting range	Unit	Standard value															
00 to 03	-	00: _Type1															
Selection	Contents																
00: _Type1	When SERVO-OFF/ Clear Deviation: Deviation Clear Input/ Level Detection During servo OFF, deviation clear is always executed. While deviation clear input is ON, deviation clear is always executed.																
01: _Type2	When SERVO-OFF/ Clear Deviation: Deviation Clear Input/ Edge Detection At the edge of OFF→ON of deviation clear input, deviation clear is executed.																
02: _Type3	When SERVO-OFF/ Not Clear Deviation: Deviation Clear Input/ Level Detection During servo OFF, deviation clear is not executed. (After servo ON, the motor may operate suddenly.)																
03: _Type4	When SERVO-OFF/ Not Clear Deviation: Deviation Clear Input/ Edge Detection During servo OFF, deviation clear is not executed. (After servo ON, the motor may operate suddenly.)																
20	Preset Velocity Command 1 [VC1] Refer to "Chapter7, Adjustment・Functions, Internal velocity command".																
	<table border="1"> <thead> <tr> <th>Setting range</th> <th>Unit</th> <th>Standard value</th> </tr> </thead> <tbody> <tr> <td>0 to 32767</td> <td>min⁻¹</td> <td>100</td> </tr> </tbody> </table>	Setting range	Unit	Standard value	0 to 32767	min ⁻¹	100	Parameter for setting velocity command of internal velocity operation. When internal velocity selection input 1 is valid and internal velocity selection input 2 is invalid, this parameter is enabled.									
Setting range	Unit	Standard value															
0 to 32767	min ⁻¹	100															
21	Preset Velocity Command 1 [VC1] Refer to "Chapter7, Adjustment・Functions, Internal velocity command".																
	<table border="1"> <thead> <tr> <th>Setting range</th> <th>Unit</th> <th>Standard value</th> </tr> </thead> <tbody> <tr> <td>0 to 32767</td> <td>min⁻¹</td> <td>200</td> </tr> </tbody> </table>	Setting range	Unit	Standard value	0 to 32767	min ⁻¹	200	Parameter for setting velocity command of internal velocity operation. When internal velocity selection input 1 is invalid and internal velocity selection input 2 is valid, this parameter is enabled.									
Setting range	Unit	Standard value															
0 to 32767	min ⁻¹	200															
22	Preset Velocity Command 1 [VC1] Refer to "Chapter7, Adjustment・Functions, Internal velocity command".																
	<table border="1"> <thead> <tr> <th>Setting range</th> <th>Unit</th> <th>Standard value</th> </tr> </thead> <tbody> <tr> <td>0 to 32767</td> <td>min⁻¹</td> <td>300</td> </tr> </tbody> </table>	Setting range	Unit	Standard value	0 to 32767	min ⁻¹	300	Parameter for setting velocity command of internal velocity operation. When internal velocity selection input 1 is valid and internal velocity selection input 2 is valid, this parameter is enabled.									
Setting range	Unit	Standard value															
0 to 32767	min ⁻¹	300															
23	Velocity Compensation Command, Input Selection [VCOMSEL]																
	<table border="1"> <thead> <tr> <th>Setting range</th> <th>Unit</th> <th>Standard value</th> </tr> </thead> <tbody> <tr> <td>01 to 02</td> <td>-</td> <td>02: _VCOMP</td> </tr> </tbody> </table>	Setting range	Unit	Standard value	01 to 02	-	02: _VCOMP	Select velocity addition command input from the contents below. <table border="1"> <thead> <tr> <th>Selection</th> <th>Contents</th> </tr> </thead> <tbody> <tr> <td>01: _Analog _Input</td> <td>Apply Analog Velocity Compensation Command When velocity addition function is valid, analog velocity addition command value is used.</td> </tr> <tr> <td>02: _VCOMP</td> <td>Apply Preset Velocity Compensation Command When velocity addition function is valid, internal velocity addition command value id used.</td> </tr> </tbody> </table>	Selection	Contents	01: _Analog _Input	Apply Analog Velocity Compensation Command When velocity addition function is valid, analog velocity addition command value is used.	02: _VCOMP	Apply Preset Velocity Compensation Command When velocity addition function is valid, internal velocity addition command value id used.			
Setting range	Unit	Standard value															
01 to 02	-	02: _VCOMP															
Selection	Contents																
01: _Analog _Input	Apply Analog Velocity Compensation Command When velocity addition function is valid, analog velocity addition command value is used.																
02: _VCOMP	Apply Preset Velocity Compensation Command When velocity addition function is valid, internal velocity addition command value id used.																
24	Preset Velocity Compensation Command [VCOMP]																
	<table border="1"> <thead> <tr> <th>Setting range</th> <th>Unit</th> <th>Standard value</th> </tr> </thead> <tbody> <tr> <td>-9999 to +9999</td> <td>min⁻¹</td> <td>0</td> </tr> </tbody> </table>	Setting range	Unit	Standard value	-9999 to +9999	min ⁻¹	0	Parameter for using velocity addition command in a fixed value when velocity addition function is used.									
Setting range	Unit	Standard value															
-9999 to +9999	min ⁻¹	0															

5.Parameter

[Parameter setting value [Group8]]

Page	Contents							
25	Analog Velocity Command, Reference (Analog Velocity Compensation Command, Ref.) [VCGN]							
	<table border="1"> <thead> <tr> <th>Setting range</th> <th>Unit</th> <th>Standard value</th> </tr> </thead> <tbody> <tr> <td>0 to 4000</td> <td>min⁻¹/V</td> <td>500</td> </tr> </tbody> </table>	Setting range	Unit	Standard value	0 to 4000	min ⁻¹ /V	500	Parameter for setting analog velocity (addition) command scaling.
Setting range	Unit	Standard value						
0 to 4000	min ⁻¹ /V	500						
26	Velocity Command, Acceleration Time Constant [TVACC]							
	<table border="1"> <thead> <tr> <th>Setting range</th> <th>Unit</th> <th>Standard value</th> </tr> </thead> <tbody> <tr> <td>0 to 16000</td> <td>ms</td> <td>0</td> </tr> </tbody> </table>	Setting range	Unit	Standard value	0 to 16000	ms	0	Parameter for restricting acceleration of command, to analog velocity command input, analog velocity addition input, internal velocity command, and JOG operatin. Acceleration: 0 min ⁻¹ → forward·reverse rotation Sets the acceleration time for 1000 min ⁻¹ .
Setting range	Unit	Standard value						
0 to 16000	ms	0						
27	Velocity Command, Deceleation Time Constant [TVDEC]							
	<table border="1"> <thead> <tr> <th>Setting range</th> <th>Unit</th> <th>Standard value</th> </tr> </thead> <tbody> <tr> <td>0 to 16000</td> <td>ms</td> <td>0</td> </tr> </tbody> </table>	Setting range	Unit	Standard value	0 to 16000	ms	0	Parameter for restricting deceleration of command, to analog velocity command input, analog velocity addition input, internal velocity command, and JOG operatin. Deceleration: forward·reverse rotation → 0 min ⁻¹ Sets the deceleration time for 1000 min ⁻¹ .
Setting range	Unit	Standard value						
0 to 16000	ms	0						
28	Velocity Limit [VCLM]							
	<table border="1"> <thead> <tr> <th>Setting range</th> <th>Unit</th> <th>Standard value</th> </tr> </thead> <tbody> <tr> <td>1 to 65535</td> <td>min⁻¹</td> <td>65535</td> </tr> </tbody> </table>	Setting range	Unit	Standard value	1 to 65535	min ⁻¹	65535	Parameter for restricting the velocity command. Sets the maximum value of velocity command. Velocity command is restricted by this value at operations of position control and velocity control. When the set value is larger than 50000, velocity command is restricted at (maximum speed×1.1). Set this parameter when it is to be restricted at lower than (motor rotation speed ×1.1). (Use the standard value usually.)
Setting range	Unit	Standard value						
1 to 65535	min ⁻¹	65535						
30	Torque Compensation Command, Input Selection [TCOMSEL]							
	<table border="1"> <thead> <tr> <th>Setting range</th> <th>Unit</th> <th>Standard value</th> </tr> </thead> <tbody> <tr> <td>01 to 02</td> <td>-</td> <td>02: TCOMP</td> </tr> </tbody> </table>	Setting range	Unit	Standard value	01 to 02	-	02: TCOMP	Selects the torque addition command input from the contents below.
	Setting range	Unit	Standard value					
01 to 02	-	02: TCOMP						
<table border="1"> <thead> <tr> <th>Selection</th> <th>Contents</th> </tr> </thead> <tbody> <tr> <td>01: Analog Input</td> <td>When torque addition function is valid, analog torque addition command value is used.</td> </tr> <tr> <td>02: TCOMP</td> <td>When torque addition function is valid, internal torque addition command value is used.</td> </tr> </tbody> </table>	Selection	Contents	01: Analog Input	When torque addition function is valid, analog torque addition command value is used.	02: TCOMP	When torque addition function is valid, internal torque addition command value is used.		
Selection	Contents							
01: Analog Input	When torque addition function is valid, analog torque addition command value is used.							
02: TCOMP	When torque addition function is valid, internal torque addition command value is used.							
31	Preset Torque Compensation Command 1 [TCOMP1]							
	<table border="1"> <thead> <tr> <th>Setting range</th> <th>Unit</th> <th>Standard value</th> </tr> </thead> <tbody> <tr> <td>-500 to +500</td> <td>%</td> <td>0</td> </tr> </tbody> </table>	Setting range	Unit	Standard value	-500 to +500	%	0	Parameter for using torque addition command in a fixed value, when torque addition function is used.
Setting range	Unit	Standard value						
-500 to +500	%	0						
32	Preset Torque Compensation Command 2 [TCOMP2]							
	<table border="1"> <thead> <tr> <th>Setting range</th> <th>Unit</th> <th>Standard value</th> </tr> </thead> <tbody> <tr> <td>-500 to +500</td> <td>%</td> <td>0</td> </tr> </tbody> </table>	Setting range	Unit	Standard value	-500 to +500	%	0	Parameter for using torque addition command in a fixed value, when torque addition function is used.
Setting range	Unit	Standard value						
-500 to +500	%	0						
33	Analog Torque Command, Reference [TCGN]							
	<table border="1"> <thead> <tr> <th>Setting range</th> <th>Unit</th> <th>Standard value</th> </tr> </thead> <tbody> <tr> <td>0 to 500</td> <td>%/V</td> <td>50</td> </tr> </tbody> </table>	Setting range	Unit	Standard value	0 to 500	%/V	50	Parameter for setting analog torque command scaling.
Setting range	Unit	Standard value						
0 to 500	%/V	50						
34	Analog Torque Compensation Command, Reference [TCOMPGN]							
	<table border="1"> <thead> <tr> <th>Setting range</th> <th>Unit</th> <th>Standard value</th> </tr> </thead> <tbody> <tr> <td>0 to 500</td> <td>%/V</td> <td>50</td> </tr> </tbody> </table>	Setting range	Unit	Standard value	0 to 500	%/V	50	Parameter for adjusting torque addition command input scaling.
Setting range	Unit	Standard value						
0 to 500	%/V	50						

5.Parameter

[Parameter setting value [Group8]]

Page	Contents																
35	Torque Limit, Input Selection [TLSEL]																
	<table border="1"> <thead> <tr> <th>Setting range</th> <th>Unit</th> <th>Standard value</th> </tr> </thead> <tbody> <tr> <td>00 to 03</td> <td>-</td> <td>00: _TCLM</td> </tr> </tbody> </table>		Setting range	Unit	Standard value	00 to 03	-	00: _TCLM	Select the torque command limiting method from the contents below. The selection of limit is when torque command limit function is valid.								
	Setting range	Unit	Standard value														
	00 to 03	-	00: _TCLM														
	<table border="1"> <thead> <tr> <th>Selection</th> <th></th> <th>Contents</th> </tr> </thead> <tbody> <tr> <td>00: _TCLM</td> <td>Internal torque limit value (TCLM) is used.</td> <td>Forward side (forward direction): limited at internal set value. Reverse side (reverse direction): limited at internal set value.</td> </tr> <tr> <td>01: _Analog_1</td> <td>External torque limit input is used. Forward side/ F-TLA, Reverse side/ R-TLA (-voltage input)</td> <td>Forward side (forward direction): limited at + voltage input at F-TLA. Reverse side (reverse direction): limited at - voltage input at R-TLA.</td> </tr> <tr> <td>02: _Analog_2</td> <td>External torque limit input is used. Forward side/F-TLA, Reverse side/R-TLA (+voltage input)</td> <td>Forward side (forward direction): limited at + voltage input at F-TLA. Reverse side (reverse direction): limited at + voltage input at R-TLA.</td> </tr> <tr> <td>03: _Analog_3</td> <td>External torque limit input is used. Forward side/ F-TLA Reverse side/ F-TLA</td> <td>Forward (forward direction) side: limited at + voltage input at F-TLA. Reverse (reverse direction) side: limited at + voltage input at F-TLA.</td> </tr> </tbody> </table>			Selection		Contents	00: _TCLM	Internal torque limit value (TCLM) is used.	Forward side (forward direction): limited at internal set value. Reverse side (reverse direction): limited at internal set value.	01: _Analog_1	External torque limit input is used. Forward side/ F-TLA, Reverse side/ R-TLA (-voltage input)	Forward side (forward direction): limited at + voltage input at F-TLA. Reverse side (reverse direction): limited at - voltage input at R-TLA.	02: _Analog_2	External torque limit input is used. Forward side/F-TLA, Reverse side/R-TLA (+voltage input)	Forward side (forward direction): limited at + voltage input at F-TLA. Reverse side (reverse direction): limited at + voltage input at R-TLA.	03: _Analog_3	External torque limit input is used. Forward side/ F-TLA Reverse side/ F-TLA
Selection		Contents															
00: _TCLM	Internal torque limit value (TCLM) is used.	Forward side (forward direction): limited at internal set value. Reverse side (reverse direction): limited at internal set value.															
01: _Analog_1	External torque limit input is used. Forward side/ F-TLA, Reverse side/ R-TLA (-voltage input)	Forward side (forward direction): limited at + voltage input at F-TLA. Reverse side (reverse direction): limited at - voltage input at R-TLA.															
02: _Analog_2	External torque limit input is used. Forward side/F-TLA, Reverse side/R-TLA (+voltage input)	Forward side (forward direction): limited at + voltage input at F-TLA. Reverse side (reverse direction): limited at + voltage input at R-TLA.															
03: _Analog_3	External torque limit input is used. Forward side/ F-TLA Reverse side/ F-TLA	Forward (forward direction) side: limited at + voltage input at F-TLA. Reverse (reverse direction) side: limited at + voltage input at F-TLA.															
36	Internal Torque Limit [TCLM]																
	<table border="1"> <thead> <tr> <th>Setting range</th> <th>Unit</th> <th>Standard value</th> </tr> </thead> <tbody> <tr> <td>10 to 500</td> <td>%</td> <td>100</td> </tr> </tbody> </table>		Setting range	Unit	Standard value	10 to 500	%	100	Parameter for limiting output torque. Torque limit value is determined by comparing it with the rated output torque.(100%= rated torque) Output torque is limited at the internal torque limit set value when the torque limit input signal is functioning. Output torque is restricted by TP if a value exceeding the peak output torque TP is selected.								
Setting range	Unit	Standard value															
10 to 500	%	100															
37	Torque Limit at Sequence Operation [SQTCLM]																
	<table border="1"> <thead> <tr> <th>Setting range</th> <th>Unit</th> <th>Standard value</th> </tr> </thead> <tbody> <tr> <td>10 to 500</td> <td>%</td> <td>120</td> </tr> </tbody> </table>		Setting range	Unit	Standard value	10 to 500	%	120	Parameter for setting sequence operation torque limit value (JOG operation, holding brake operation waiting, and OT status, etc.) Torque limit value is determined by comparing it with the rated output torque. (100%=rated torque) During sequence operation, output torque is restricted by this set value. Output torque is restricted by TP if a value exceeding the peak output torque TP is selected.								
Setting range	Unit	Standard value															
10 to 500	%	120															
40	In-Position Near Range [NEAR]																
	<table border="1"> <thead> <tr> <th>Setting range</th> <th>Unit</th> <th>Standard value</th> </tr> </thead> <tbody> <tr> <td>1 to 65535</td> <td>Pulse</td> <td>500</td> </tr> </tbody> </table>		Setting range	Unit	Standard value	1 to 65535	Pulse	500	Parameter for setting the output range of near range signal (near in-position complete). Near range signal is output when the deviation counter is lower than this set value. Encoder pulse is standard irrespective of electronic gear and command multiplication functions.								
Setting range	Unit	Standard value															
1 to 65535	Pulse	500															
41	In-Position Window [INP]																
	<table border="1"> <thead> <tr> <th>Setting range</th> <th>Unit</th> <th>Standard value</th> </tr> </thead> <tbody> <tr> <td>1 to 65535</td> <td>Pulse</td> <td>100</td> </tr> </tbody> </table>		Setting range	Unit	Standard value	1 to 65535	Pulse	100	Parameter for setting output range of positioning complete signal. Positioning complete signal is output when the deviation counter is lower than this set value. Encoder pulse is standard irrespective of the electronic gear function or command multiplication function. Incremental encoder → Encoder pulse multiplied by 4 is standard. Absolute encoder (except for the ones absolute encoder with incremental output) →Absolute value is standard.								
Setting range	Unit	Standard value															
1 to 65535	Pulse	100															
42	Speed Zero Range [ZV]																
	<table border="1"> <thead> <tr> <th>Setting range</th> <th>Unit</th> <th>Standard value</th> </tr> </thead> <tbody> <tr> <td>50 to 500</td> <td>min⁻¹</td> <td>50</td> </tr> </tbody> </table>		Setting range	Unit	Standard value	50 to 500	min ⁻¹	50	Set value for detecting zero-speed status (motor stop). When the motor speed becomes lower than this value, zero-speed status is detected.								
Setting range	Unit	Standard value															
50 to 500	min ⁻¹	50															

5.Parameter

[Parameter setting value [Group8]]

Page	Contents							
43	Low Speed Range [LOWV]							
	<table border="1"> <thead> <tr> <th>Setting range</th> <th>Unit</th> <th>Standard value</th> </tr> </thead> <tbody> <tr> <td>0 to 65535</td> <td>min⁻¹</td> <td>50</td> </tr> </tbody> </table>	Setting range	Unit	Standard value	0 to 65535	min ⁻¹	50	Parameter for setting low-speed output range. When the speed is lower than this value, low-speed range is output.
Setting range	Unit	Standard value						
0 to 65535	min ⁻¹	50						
44	Speed Matching Width [VCMP]							
	<table border="1"> <thead> <tr> <th>Setting range</th> <th>Unit</th> <th>Standard value</th> </tr> </thead> <tbody> <tr> <td>0 to 65535</td> <td>min⁻¹</td> <td>50</td> </tr> </tbody> </table>	Setting range	Unit	Standard value	0 to 65535	min ⁻¹	50	Parameter for setting the range of velocity matching output. Velocity matching is output when the speed deviation (difference between speed command and actual speed) is within the setting range.
Setting range	Unit	Standard value						
0 to 65535	min ⁻¹	50						
45	High Speed Range [VA]							
	<table border="1"> <thead> <tr> <th>Setting range</th> <th>Unit</th> <th>Standard value</th> </tr> </thead> <tbody> <tr> <td>0 to 65535</td> <td>min⁻¹</td> <td>1000</td> </tr> </tbody> </table>	Setting range	Unit	Standard value	0 to 65535	min ⁻¹	1000	Parameter for setting the value for speed attainment output. When the speed exceeds this set value, velocity attainment is output. If the motor speed exceeds the selected value during torque control operations, and when the control switching function is enabled, the torque command is always set to 0. Fixed speed cannot be controlled. Avoid continuous usage in this manner.
Setting range	Unit	Standard value						
0 to 65535	min ⁻¹	1000						

5.Parameter

[Parameter setting value[Group9]]

- General parameter Group 9 [Condition settings for enabling functions]
Input signals and conditions to enable the functions of each page are set.

 Selection contents to be set are on the next page.

Page	Contents	
00	Positive Over-Travel Function [F-OT]	
	Setting range	Standard value
01	Negative Over-Travel Function [R-OT]	
	Setting range	Standard value
02	Alarm Reset Function [AL-RST]	
	Setting range	Standard value
03	Absolute Encoder Clear Function [ECLR]	
	Setting range	Standard value
04	Deviation Clear Function [CLR]	
	Setting range	Standard value
05	SERVO-ON Function [S-ON]	
	Setting range	Standard value
10	Control Mode Switching Function [MS]	
	Setting range	Standard value
11	Position Command Pulse Inhibit Function and Velocity Command Zero Clamp Function [INH/Z-STP]	
	Setting range	Standard value
12	Electric Gear Switching Function [GERS]	
	Setting range	Standard value
13	Gain Switching Function, Select Input 1 [GC1]	
	Setting range	Standard value
14	Gain Switching Function, Select Input 2 [GC2]	
	Setting range	Standard value
15	Vibration Suppressor Frequency, Select Input 1 [SUPFSEL1]	
	Setting range	Standard value
16	Vibration Suppressor Frequency, Select Input 2 [SUPFSEL2]	
	Setting range	Standard value
17	Position Loop Proportional Control, Switching Function [PLPCON]	
	Setting range	Standard value

Page	Contents	
20	Preset Velocity Command, Select Input 1 [SP1]	
	Setting range	Standard value
21	Preset Velocity Command, Select Input 2 [SP2]	
	Setting range	Standard value
22	Preset Velocity Command, Direction of Move [DIR]	
	Setting range	Standard value
23	Preset Velocity Command, Operation Start Signal Input [RUN]	
	Setting range	Standard value
24	Preset Velocity Command, Positive Move Signal Input [RUN-F]	
	Setting range	Standard value
25	Preset Velocity Command, Negative Move Signal Input [RUN-R]	
	Setting range	Standard value
26	Velocity Loop Proportional Control, Switching Function [VLPCON]	
	Setting range	Standard value
27	Velocity Compensation Function, Select Input [VCOMPS]	
	Setting range	Standard value
30	Torque Compensation Function, Select Input 1 [TCOMPS1]	
	Setting range	Standard value
31	Torque Compensation Function, Select Input 2 [TCOMPS2]	
	Setting range	Standard value
32	Torque Limit, Input Selection [TL]	
	Setting range	Standard value
33	Disturbance Observer [OBS]	
	Setting range	Standard value
40	External Error Input [EXT-E]	
	Setting range	Standard value
41	Main Power Discharge Function [DISCHARG]	
	Setting range	Standard value
42	Emergency Stop Function [EMR]	
	Setting range	Standard value

5.Parameter

[Parameter setting value[Group9]]

■ General parameter Group 9 [List of selection contents]

When functions are to be always enabled or disabled.

Selection	Contents
00: Always_Disable	Always disable the function.
01: Always_Enable	Always enable the function.

When functions are to be used with the generic input signals.

Selection	Contents
02: CONT1_ON	Enable the function when general purpose input CONT1 is ON.
03: CONT1_OFF	Enable the function when general purpose input CONT1 is OFF.
04: CONT2_ON	Enable the function when general purpose input CONT2 is ON.
05: CONT2_OFF	Enable the function when general purpose input CONT2 is OFF.
06: CONT3_ON	Enable the function when general purpose input CONT3 is ON.
07: CONT3_OFF	Enable the function when general purpose input CONT3 is OFF.
08: CONT4_ON	Enable the function when general purpose input CONT4 is ON.
09: CONT4_OFF	Enable the function when general purpose input CONT4 is OFF.
0A: CONT5_ON	Enable the function when general purpose input CONT5 is ON.
0B: CONT5_OFF	Enable the function when general purpose input CONT5 is OFF.
0C: CONT6_ON	Enable the function when general purpose input CONT6 is ON.
0D: CONT6_OFF	Enable the function when general purpose input CONT6 is OFF.
0E: CONT7_ON	Enable the function when general purpose input CONT7 is ON.
0F: CONT7_OFF	Enable the function when general purpose input CONT7 is OFF.
10: CONT8_ON	Enable the function when general purpose input CONT8 is ON.
11: CONT8_OFF	Enable the function when general purpose input CONT8 is OFF.

When functions are to be set with the conditions of servo motor rotation speed.

Selection	Contents
12: LOWV_IN	Enable the function during low speed status (speed is less than LOWV).
13: LOWV_OUT	Enable the function while low speed status is not kept.
14: VA_IN	Enable the function during high speed status (speed is more than VA).
15: VA_OUT	Enable the function while high speed status is not kept.
16: VCMP_IN	Enable the function during speed matching status (velocity deviation < VCMP).
17: VCMP_OUT	Enable the function while speed matching status is not kept.
18: ZV_IN	Enable the function during zero speed status (speed is less than ZV).
19: ZV_OUT	Enable the function while zero speed status is not kept.

When functions are to be set with the conditions of positioning signals.

Selection	Contents
20: NEAR_IN	Enable the function during NEAR status (position deviation < NEAR).
21: NEAR_OUT	Enable the function while NEAR status is not kept.
1A: INP_IN	Enable the function during In-Position status (position deviation < INP).
1B: INP_OUT	Enable the function while In-Position status is not kept.
26: INPZ_IN	Enable the function during PCMD=0 and In-position Status.
27: INPZ_OUT	Disable the function during PCMD=0 or In-position Status.

When functions are to be set with the conditions of torque / speed limit

Selection	Contents
1C: TLC_IN	Enable the function during torque limiting.
1D: TLC_OUT	Enable the function while torque limiting is not performed.
1E: VLC_IN	Enable the function during velocity limiting.
1F: VLC_OUT	Enable the function while velocity limiting is not performed.

When functions are to be set with the servo motor rotation direction and stop status.



Selection	Contents
22: VMON_>+LV	Enable the function when Moving Direction is Positive (VMON > LOWV).
23: VMON_<=+LV	Enable the function when Moving Direction is not Positive (VMON <= LOWV).
24: VMON_<-LV	Enable the function when Moving Direction is Negative (VMON < -LOWV).
25: VMON_>=-LV	Enable the function when Moving Direction is not Negative (VMON >= -LOWV).

5.Parameter

[Parameter setting value[GroupB]]

■ General parameter Group A

[General output terminal outputting condition/monitor output selection/setup software settings]

Page	Name and Contents																																													
00	General Purpose Output 1 [OUT1]																																													
	Setting range	Standard value																																												
01	General Purpose Output 2 [OUT2]																																													
	Setting range	Standard value																																												
02	General Purpose Output 3 [OUT3]																																													
	Setting range	Standard value																																												
03	General Purpose Output 4 [OUT4]																																													
	Setting range	Standard value																																												
04	General Purpose Output 5 [OUT5]																																													
	Setting range	Standard value																																												
05	General Purpose Output 6 [OUT6]																																													
	Setting range	Standard value																																												
06	General Purpose Output 7 [OUT7]																																													
	Setting range	Standard value																																												
07	General Purpose Output 8 [OUT8]																																													
	Setting range	Standard value																																												
10	Digital Monitor, Output Signal Selection [DMON]																																													
	Setting range	Standard value																																												
11	Analog Monitor 1, Output Signal Selection [MON1]																																													
	Setting range	Standard value																																												
12	Analog Monitor 2, Output Signal Selection [MON2]																																													
	Setting range	Standard value																																												
<p>Output signals for Generic output OUT1 to Generic output OUT8 are selected.</p> <p> Selection values to be set are on the next page.</p>																																														
<p>Output signals for digital monitor output are selected.</p> <p> Selection values to be set are on the next page.</p>																																														
<p>Output signals for analog monitor output 1, 2 are selected from the followings.</p>																																														
<table border="1"> <tbody> <tr><td>00</td><td>Reserved</td></tr> <tr><td>01: TMON_2V/TR</td><td>Torque (thrust) monitor 2V/ rated torque (thrust)</td></tr> <tr><td>02: TCMON_2V/TR</td><td>Torque (thrust) command monitor 2V/ rated torque (thrust)</td></tr> <tr><td>03: VMON_0.2mV/ min⁻¹</td><td>Velocity monitor 0.2mV/ min⁻¹</td></tr> <tr><td>04: VMON_1mV/ min⁻¹</td><td>Velocity monitor 1mV/ min⁻¹</td></tr> <tr><td>05: VMON_2mV/ min⁻¹</td><td>Velocity monitor 2mV/ min⁻¹</td></tr> <tr><td>06: VMON_3mV/ min⁻¹</td><td>Velocity monitor 3mV/ min⁻¹</td></tr> <tr><td>07: VCMON_0.2mV/ min⁻¹</td><td>Velocity command monitor 0.2mV/ min⁻¹</td></tr> <tr><td>08: VCMON_1mV/ min⁻¹</td><td>Velocity command monitor 1mV/ min⁻¹</td></tr> <tr><td>09: VCMON_2mV/ min⁻¹</td><td>Velocity command monitor 2mV/ min⁻¹</td></tr> <tr><td>0A: VCMON_3mV/ min⁻¹</td><td>Velocity command monitor 3mV/ min⁻¹</td></tr> <tr><td>0B: PMON_0.1mV/P</td><td>Position deviation counter monitor 0.1mV/ Pulse</td></tr> <tr><td>0C: PMON_1mV/P</td><td>Position deviation counter monitor 1mV/ Pulse</td></tr> <tr><td>0D: PMON_10mV/P</td><td>Position deviation counter monitor 10mV/ Pulse</td></tr> <tr><td>0E: PMON_20mV/P</td><td>Position deviation counter monitor 20mV/ Pulse</td></tr> <tr><td>0F: PMON_50mV/P</td><td>Position deviation counter monitor 50mV/Pulse</td></tr> <tr><td>10: FMON_2mV/kP/s</td><td>Position command pulse monitor (position command pulse input frequency)2mV/kPulse/s</td></tr> <tr><td>11: FMON_10mV/kP/s</td><td>Position command pulse monitor (position command pulse input frequency)10mV/kPulse/s</td></tr> <tr><td>12: TLMON_EST_2V/TR</td><td>Load torque (thrust) monitor (estimated value) 2V/ rated torque (thrust)</td></tr> <tr><td>13: Sine-U</td><td>U phase electric angle Sin 8Vpeak</td></tr> <tr><td>14: VBUS_1V/DC100V</td><td>Main circuit DC voltage 1V/DC100V</td></tr> <tr><td>15: VBUS_1V/DC10V</td><td>Main circuit DC voltage 1V/DC10V</td></tr> </tbody> </table>			00	Reserved	01: TMON_2V/TR	Torque (thrust) monitor 2V/ rated torque (thrust)	02: TCMON_2V/TR	Torque (thrust) command monitor 2V/ rated torque (thrust)	03: VMON_0.2mV/ min ⁻¹	Velocity monitor 0.2mV/ min ⁻¹	04: VMON_1mV/ min ⁻¹	Velocity monitor 1mV/ min ⁻¹	05: VMON_2mV/ min ⁻¹	Velocity monitor 2mV/ min ⁻¹	06: VMON_3mV/ min ⁻¹	Velocity monitor 3mV/ min ⁻¹	07: VCMON_0.2mV/ min ⁻¹	Velocity command monitor 0.2mV/ min ⁻¹	08: VCMON_1mV/ min ⁻¹	Velocity command monitor 1mV/ min ⁻¹	09: VCMON_2mV/ min ⁻¹	Velocity command monitor 2mV/ min ⁻¹	0A: VCMON_3mV/ min ⁻¹	Velocity command monitor 3mV/ min ⁻¹	0B: PMON_0.1mV/P	Position deviation counter monitor 0.1mV/ Pulse	0C: PMON_1mV/P	Position deviation counter monitor 1mV/ Pulse	0D: PMON_10mV/P	Position deviation counter monitor 10mV/ Pulse	0E: PMON_20mV/P	Position deviation counter monitor 20mV/ Pulse	0F: PMON_50mV/P	Position deviation counter monitor 50mV/Pulse	10: FMON_2mV/kP/s	Position command pulse monitor (position command pulse input frequency)2mV/kPulse/s	11: FMON_10mV/kP/s	Position command pulse monitor (position command pulse input frequency)10mV/kPulse/s	12: TLMON_EST_2V/TR	Load torque (thrust) monitor (estimated value) 2V/ rated torque (thrust)	13: Sine-U	U phase electric angle Sin 8Vpeak	14: VBUS_1V/DC100V	Main circuit DC voltage 1V/DC100V	15: VBUS_1V/DC10V	Main circuit DC voltage 1V/DC10V
00	Reserved																																													
01: TMON_2V/TR	Torque (thrust) monitor 2V/ rated torque (thrust)																																													
02: TCMON_2V/TR	Torque (thrust) command monitor 2V/ rated torque (thrust)																																													
03: VMON_0.2mV/ min ⁻¹	Velocity monitor 0.2mV/ min ⁻¹																																													
04: VMON_1mV/ min ⁻¹	Velocity monitor 1mV/ min ⁻¹																																													
05: VMON_2mV/ min ⁻¹	Velocity monitor 2mV/ min ⁻¹																																													
06: VMON_3mV/ min ⁻¹	Velocity monitor 3mV/ min ⁻¹																																													
07: VCMON_0.2mV/ min ⁻¹	Velocity command monitor 0.2mV/ min ⁻¹																																													
08: VCMON_1mV/ min ⁻¹	Velocity command monitor 1mV/ min ⁻¹																																													
09: VCMON_2mV/ min ⁻¹	Velocity command monitor 2mV/ min ⁻¹																																													
0A: VCMON_3mV/ min ⁻¹	Velocity command monitor 3mV/ min ⁻¹																																													
0B: PMON_0.1mV/P	Position deviation counter monitor 0.1mV/ Pulse																																													
0C: PMON_1mV/P	Position deviation counter monitor 1mV/ Pulse																																													
0D: PMON_10mV/P	Position deviation counter monitor 10mV/ Pulse																																													
0E: PMON_20mV/P	Position deviation counter monitor 20mV/ Pulse																																													
0F: PMON_50mV/P	Position deviation counter monitor 50mV/Pulse																																													
10: FMON_2mV/kP/s	Position command pulse monitor (position command pulse input frequency)2mV/kPulse/s																																													
11: FMON_10mV/kP/s	Position command pulse monitor (position command pulse input frequency)10mV/kPulse/s																																													
12: TLMON_EST_2V/TR	Load torque (thrust) monitor (estimated value) 2V/ rated torque (thrust)																																													
13: Sine-U	U phase electric angle Sin 8Vpeak																																													
14: VBUS_1V/DC100V	Main circuit DC voltage 1V/DC100V																																													
15: VBUS_1V/DC10V	Main circuit DC voltage 1V/DC10V																																													

5.Parameter

[Parameter setting value[GroupB]]

■ General output OUT1 to Generic output OUT8, List of selection contents for digital monitor output

When functions are to be always enabled or disabled.

Selection	Contents
00: Always_OFF	The output is always OFF.
01: Always_ON	The output is always ON.

When Generic input signal status is to be output.

Selection	Contents	Selection	Contents
3A: CONT1_ON	The output is ON while general purpose input CONT 1 is ON.	42: CONT5_ON	The output is ON while general purpose input CONT 5 is ON.
3B: CONT1_OFF	The output is OFF while general purpose input CONT 1 is ON.	43: CONT5_OFF	The output is OFF while general purpose input CONT 5 is ON.
3C: CONT2_ON	The output is ON while general purpose input CONT 2 is ON.	44: CONT6_ON	The output is ON while general purpose input CONT 6 is ON.
3D: CONT2_OFF	The output is OFF while general purpose input CONT 2 is ON.	45: CONT6_OFF	The output is OFF while general purpose input CONT6 is ON.
3E: CONT3_ON	The output is ON while general purpose input CONT 3 is ON.	46: CONT7_ON	The output is ON while general purpose input CONT 7 is ON.
3F: CONT3_OFF	The output is OFF while general purpose input CONT 3 is ON.	47: CONT7_OFF	The output is OFF while general purpose input CONT 7 is ON.
40: CONT4_ON	The output is ON while general purpose input CONT 4 is ON.	48: CONT8_ON	The output is ON while general purpose input CONT 8 is ON.
41: CONT4_OFF	The output is OFF while general purpose input CONT 4 is ON.	49: CONT8_OFF	The output is OFF while general purpose input CONT 8 is ON.

When servo amplifier inner status is to be output.

Selection	Contents	Selection	Contents
02: S-RDY_ON	The output is ON during Servo Ready complete.	16: ZV_ON	The output is ON during zero speed status (speed is less than ZV).
03: S-RDY_OFF	The output is OFF during Servo Ready complete.	17: ZV_OFF	The output is OFF during zero speed status (speed is less than ZV).
58: S-RDY2_ON	The output is ON during Servo Ready complete.	1C: CMD-ACK_ON	The output is ON while command can be accepted.
59: S-RDY2_OFF	The output is OFF during Servo Ready complete.	1D: CMD-ACK_OFF	The output is OFF while command can be accepted.
04: P-ON_ON	The output is ON while the main power supply is turned on.	1E: GC-ACK_ON	The output is ON during gain switching.
05: P-ON_OFF	The output is OFF while the main power supply is turned on.	1F: GC-ACK_OFF	The output is OFF during gain switching.
06: A-RDY_ON	The output is ON during the main power supply ON permission.	20: PCON-ACK_ON	The output is ON during velocity loop proportional control switching.
07: A-RDY_OFF	The output is OFF during the main power supply ON permission.	21: PCON-ACK_OFF	The output is OFF during velocity loop proportional control switching.
08: S-ON_ON	The output is ON during motor excitation.	22: GERS-ACK_ON	The output is ON during electric gear switching.
09: S-ON_OFF	The output is OFF during motor excitation.	23: GERS-ACK_OFF	The output is OFF during electric gear switching.
0A: MBR-ON_ON	The output is ON while holding brake excitation signal outputs.	24: MS-ACK_ON	The output is ON during control mode switching.
0B: MBR-ON_OFF	The output is OFF while holding brake excitation signal outputs.	25: MS-ACK_OFF	The output is OFF during control mode switching.
0C: TLC_ON	The output is ON during torque limiting.	26: F-OT_ON	The output is ON during positive over-travel status.
0D: TLC_OFF	The output is OFF during torque limiting.	27: F-OT_OFF	The output is OFF during positive over-travel status.
0E: VLC_ON	The output is ON during velocity limiting.	28: R-OT_ON	The output is ON during negative over-travel status.
0F: VLC_OFF	The output is OFF during velocity limiting.	29: R-OT_OFF	The output is OFF during negative over-travel status.
10: LOWV_ON	The output is ON during low speed status (speed is less than LOWV).	4A: CHARGE_ON	The output is ON while main power supply (capacitor) is charging.
11: LOWV_OFF	The output is OFF during low speed status (speed is less than LOWV).	4B: CHARGE_OFF	The output is OFF while main power supply (capacitor) is charging.
12: VA_ON	The output is ON during high speed status (speed is more than VA).	4C: DB_OFF	The output is OFF during dynamic braking.
13: VA_OFF	The output is OFF during high speed status (speed is more than VA).	4D: DB_ON	The output is ON during dynamic braking.
14: VCMP_ON	The output is ON during speed matching status (velocity deviation < VCMP).		
15: VCMP_OFF	The output is OFF during speed matching status (velocity deviation < VCMP).		

When positioning signal is to be output.

Selection	Contents
18: INP_ON	The output is ON during In-Position status (position deviation < INP).
19: INP_OFF	The output is OFF during In-Position status (position deviation < INP).
1A: NEAR_ON	The output is ON during In-Position Near status (position deviation < NEAR).
1B: NEAR_OFF	The output is OFF during In-Position Near status (position deviation < NEAR).
5A: INPZ_ON	The output is ON during PCMD=0 and In-position Status.
5B: INPZ_OFF	The output is OFF during PCMD=0 and In-position Status.

When warning signal is to be output.

Selection	Contents
2A: WNG-OFW_ON	The output is ON during following warning status (position deviation > OFWLV).
2B: WNG-OFW_OFF	The output is OFF during following warning status (position deviation > OFWLV).
2C: WNG-OLW_ON	The output is ON during over-load warning status.
2D: WNG-OLW_OFF	The output is OFF during over-load warning status.
2E: WNG-ROLW_ON	The output is ON during regenerative over-load warning status.
2F: WNG-ROLW_OFF	The output is OFF during regenerative over-load warning status.
30: WNG-BAT_ON	The output is ON during battery warning.
31: WNG-BAT_OFF	The output is OFF during battery warning.

When alarm signals are to be output.



Selection	Contents
32: ALM5_ON	Output alarm code, bit 5. (Positive logic).
33: ALM5_OFF	Output alarm code, bit 5. (Negative logic).
34: ALM6_ON	Output alarm code, bit 6. (Positive logic).
35: ALM6_OFF	Output alarm code, bit 6. (Negative logic).
36: ALM7_ON	Output alarm code, bit 7. (Positive logic).
37: ALM7_OFF	Output alarm code, bit 7. (Negative logic).
38: ALM_ON	The output is ON during alarm status.
39: ALM_OFF	The output is OFF during alarm status.

When alarm signals are to be made compatible with PY.

Selection	Contents
50: PYALM1_ON	Output PY compatible alarm code 1. (Positive logic).
51: PYALM1_OFF	Output PY compatible alarm code 1. (Negative logic).
52: PYALM2_ON	Output PY compatible alarm code 2. (Positive logic).
53: PYALM2_OFF	Output PY compatible alarm code 1. (Negative logic).
54: PYALM4_ON	Output PY compatible alarm code 4. (Positive logic).
55: PYALM4_OFF	Output PY compatible alarm code 4. (Negative logic).
56: PYALM8_ON	Output PY compatible alarm code 8. (Positive logic).
57: PYALM8_OFF	Output PY compatible alarm code 8. (Negative logic).

5.Parameter

[Parameter setting value[GroupB]]

Page	Contents																					
13	Analog monitor output polarity [MONPOL]																					
	<table border="1"> <thead> <tr> <th>Setting range</th> <th>Standard value</th> </tr> </thead> <tbody> <tr> <td>00 to 08</td> <td>00: MON1+_MON2+</td> </tr> </tbody> </table>	Setting range	Standard value	00 to 08	00: MON1+_MON2+	The output polarity of analog monitor output MON1 and MON2 is selected from the contents below.																
	Setting range	Standard value																				
	00 to 08	00: MON1+_MON2+																				
	<table border="1"> <thead> <tr> <th>Selection</th> <th>Contents</th> </tr> </thead> <tbody> <tr> <td>00:_MON1+_MON2+</td> <td>MON1: Output the positive voltage at forward rotation (positive direction). Output the positive/negative voltage. MON2: Output the positive voltage at forward rotation (positive direction). Output the positive/negative voltage.</td> </tr> <tr> <td>01:_MON1-_MON2+</td> <td>MON1: Output the negative voltage at forward rotation (positive direction). Output the positive/negative voltage. MON2: Output the positive voltage at forward rotation (positive direction). Output the positive/negative voltage.</td> </tr> <tr> <td>02:_MON1+_MON2-</td> <td>MON1: Output the positive voltage at forward rotation (positive direction). Output the positive/negative voltage. MON2: Output the negative voltage at forward rotation (positive direction). Output the positive/negative voltage.</td> </tr> <tr> <td>03:_MON1-_MON2-</td> <td>MON1: Output the negative voltage at forward rotation (positive direction). Output the positive/negative voltage. MON2: Output the negative voltage at forward rotation (positive direction). Output the positive/negative voltage.</td> </tr> <tr> <td>04:_MON1ABS_MON2+</td> <td>MON1: Output the positive voltage at both forward rotation (positive direction) and reverse rotation (reverse direction). MON2: Output the positive voltage at forward rotation (positive direction). Output the positive/negative voltage.</td> </tr> <tr> <td>05:_MON1ABS_MON2-</td> <td>MON1: Output the positive voltage at both forward rotation (positive direction) and reverse rotation (reverse direction). MON2: Output the negative voltage at forward rotation (positive direction). Output the positive/negative voltage.</td> </tr> <tr> <td>06:_MON1+_MON2ABS</td> <td>MON1: Output the positive voltage at forward rotation (positive direction). Output the positive/negative voltage. MON2: Output the positive voltage at both forward rotation (positive direction) and reverse rotation (reverse direction).</td> </tr> <tr> <td>07:_MON1-_MON2ABS</td> <td>MON1: Output the negative voltage at forward rotation (positive direction). Output the positive/negative voltage. MON2: Output the positive voltage at both forward rotation (positive direction) and reverse rotation (reverse direction).</td> </tr> <tr> <td>08:_MON1ABS_MON2ABS</td> <td>MON1: Output the positive voltage at both forward rotation (positive direction) and reverse rotation (reverse direction). MON2: Output the positive voltage at both forward rotation (positive direction) and reverse rotation (reverse direction).</td> </tr> </tbody> </table>	Selection	Contents	00:_MON1+_MON2+	MON1: Output the positive voltage at forward rotation (positive direction). Output the positive/negative voltage. MON2: Output the positive voltage at forward rotation (positive direction). Output the positive/negative voltage.	01:_MON1-_MON2+	MON1: Output the negative voltage at forward rotation (positive direction). Output the positive/negative voltage. MON2: Output the positive voltage at forward rotation (positive direction). Output the positive/negative voltage.	02:_MON1+_MON2-	MON1: Output the positive voltage at forward rotation (positive direction). Output the positive/negative voltage. MON2: Output the negative voltage at forward rotation (positive direction). Output the positive/negative voltage.	03:_MON1-_MON2-	MON1: Output the negative voltage at forward rotation (positive direction). Output the positive/negative voltage. MON2: Output the negative voltage at forward rotation (positive direction). Output the positive/negative voltage.	04:_MON1ABS_MON2+	MON1: Output the positive voltage at both forward rotation (positive direction) and reverse rotation (reverse direction). MON2: Output the positive voltage at forward rotation (positive direction). Output the positive/negative voltage.	05:_MON1ABS_MON2-	MON1: Output the positive voltage at both forward rotation (positive direction) and reverse rotation (reverse direction). MON2: Output the negative voltage at forward rotation (positive direction). Output the positive/negative voltage.	06:_MON1+_MON2ABS	MON1: Output the positive voltage at forward rotation (positive direction). Output the positive/negative voltage. MON2: Output the positive voltage at both forward rotation (positive direction) and reverse rotation (reverse direction).	07:_MON1-_MON2ABS	MON1: Output the negative voltage at forward rotation (positive direction). Output the positive/negative voltage. MON2: Output the positive voltage at both forward rotation (positive direction) and reverse rotation (reverse direction).	08:_MON1ABS_MON2ABS	MON1: Output the positive voltage at both forward rotation (positive direction) and reverse rotation (reverse direction). MON2: Output the positive voltage at both forward rotation (positive direction) and reverse rotation (reverse direction).	
	Selection	Contents																				
	00:_MON1+_MON2+	MON1: Output the positive voltage at forward rotation (positive direction). Output the positive/negative voltage. MON2: Output the positive voltage at forward rotation (positive direction). Output the positive/negative voltage.																				
	01:_MON1-_MON2+	MON1: Output the negative voltage at forward rotation (positive direction). Output the positive/negative voltage. MON2: Output the positive voltage at forward rotation (positive direction). Output the positive/negative voltage.																				
	02:_MON1+_MON2-	MON1: Output the positive voltage at forward rotation (positive direction). Output the positive/negative voltage. MON2: Output the negative voltage at forward rotation (positive direction). Output the positive/negative voltage.																				
	03:_MON1-_MON2-	MON1: Output the negative voltage at forward rotation (positive direction). Output the positive/negative voltage. MON2: Output the negative voltage at forward rotation (positive direction). Output the positive/negative voltage.																				
04:_MON1ABS_MON2+	MON1: Output the positive voltage at both forward rotation (positive direction) and reverse rotation (reverse direction). MON2: Output the positive voltage at forward rotation (positive direction). Output the positive/negative voltage.																					
05:_MON1ABS_MON2-	MON1: Output the positive voltage at both forward rotation (positive direction) and reverse rotation (reverse direction). MON2: Output the negative voltage at forward rotation (positive direction). Output the positive/negative voltage.																					
06:_MON1+_MON2ABS	MON1: Output the positive voltage at forward rotation (positive direction). Output the positive/negative voltage. MON2: Output the positive voltage at both forward rotation (positive direction) and reverse rotation (reverse direction).																					
07:_MON1-_MON2ABS	MON1: Output the negative voltage at forward rotation (positive direction). Output the positive/negative voltage. MON2: Output the positive voltage at both forward rotation (positive direction) and reverse rotation (reverse direction).																					
08:_MON1ABS_MON2ABS	MON1: Output the positive voltage at both forward rotation (positive direction) and reverse rotation (reverse direction). MON2: Output the positive voltage at both forward rotation (positive direction) and reverse rotation (reverse direction).																					
20	Setup Software, Communication Axis Number [COMAXIS]																					
	<table border="1"> <thead> <tr> <th>Setting range</th> <th>Standard value</th> </tr> </thead> <tbody> <tr> <td>01 to 0F</td> <td>01: #1</td> </tr> </tbody> </table>	Setting range	Standard value	01 to 0F	01: #1	The axis number for communication with PC is selected from the contents below.  The selected value is enabled after turning ON the control power again.																
Setting range	Standard value																					
01 to 0F	01: #1																					
	<table border="1"> <thead> <tr> <th>Selection</th> <th>Selection</th> </tr> </thead> <tbody> <tr><td>01: #1</td><td>09: #9</td></tr> <tr><td>02: #2</td><td>0A: #A</td></tr> <tr><td>03: #3</td><td>0B: #B</td></tr> <tr><td>04: #4</td><td>0C: #C</td></tr> <tr><td>05: #5</td><td>0D: #D</td></tr> <tr><td>06: #6</td><td>0E: #E</td></tr> <tr><td>07: #7</td><td>0F: #F</td></tr> <tr><td>08: #8</td><td></td></tr> </tbody> </table>	Selection	Selection	01: #1	09: #9	02: #2	0A: #A	03: #3	0B: #B	04: #4	0C: #C	05: #5	0D: #D	06: #6	0E: #E	07: #7	0F: #F	08: #8				
Selection	Selection																					
01: #1	09: #9																					
02: #2	0A: #A																					
03: #3	0B: #B																					
04: #4	0C: #C																					
05: #5	0D: #D																					
06: #6	0E: #E																					
07: #7	0F: #F																					
08: #8																						
21	Setup Software, Communication Baud Rate [COMBAUD]																					
	<table border="1"> <thead> <tr> <th>Setting range</th> <th>Standard value</th> </tr> </thead> <tbody> <tr> <td>00 to 05</td> <td>05: 38400bps</td> </tr> </tbody> </table>	Setting range	Standard value	00 to 05	05: 38400bps	The baud rate for communication with PC is selected from the contents below.  The selected value is enabled after turning ON the control power again.																
Setting range	Standard value																					
00 to 05	05: 38400bps																					
	<table border="1"> <thead> <tr> <th>Selection</th> </tr> </thead> <tbody> <tr><td>00: 1200bps</td></tr> <tr><td>01: 2400bps</td></tr> <tr><td>02: 4800bps</td></tr> <tr><td>03: 9600bps</td></tr> <tr><td>04: 19200bps</td></tr> <tr><td>05: 38400bps</td></tr> </tbody> </table>	Selection	00: 1200bps	01: 2400bps	02: 4800bps	03: 9600bps	04: 19200bps	05: 38400bps														
Selection																						
00: 1200bps																						
01: 2400bps																						
02: 4800bps																						
03: 9600bps																						
04: 19200bps																						
05: 38400bps																						

5.Parameter

[Parameter setting value[GroupB]]

■ General parameter Group B [sequence/alarm related settings]

Page	Contents						
00	JOG Velocity Command [JOGVC]						
	<table border="1"> <thead> <tr> <th>Setting range</th> <th>Unit</th> <th>Standard value</th> </tr> </thead> <tbody> <tr> <td>0 to 32767</td> <td>min⁻¹</td> <td>50</td> </tr> </tbody> </table>	Setting range	Unit	Standard value	0 to 32767	min ⁻¹	50
Setting range	Unit	Standard value					
0 to 32767	min ⁻¹	50					
10	Dynamic Brake Action Selection [DBOPE]						
	<table border="1"> <thead> <tr> <th>Setting range</th> <th>Unit</th> <th>Standard value</th> </tr> </thead> <tbody> <tr> <td>00 to 05</td> <td>-</td> <td>04: SB Free</td> </tr> </tbody> </table>	Setting range	Unit	Standard value	00 to 05	-	04: SB Free
Setting range	Unit	Standard value					
00 to 05	-	04: SB Free					
10	Selection						
	00: Free Free	When Servo-OFF, Free-Run is operated. After stops, Motor-Free is operated.					
	01: Free DB	When Servo-OFF, Free-Run is operated. After stops, Dynamic-Braking is performed.					
	02: DB Free	When S-OFF, Dynamic-Braking is performed. After stops, Motor-Free is operated.					
	03: DB DB	When S-OFF, Dynamic-Braking is performed. After stops, Dynamic-Braking.					
	04: SB Free	When Servo-OFF, Servo-Braking is performed. After stops, Motor-Free is operated.					
	05: SB DB	When Servo-OFF, Servo-Braking is performed. After stops, Dynamic-Braking.					
11	Over-Travel Action Selection [ACTOT]						
	<table border="1"> <thead> <tr> <th>Setting range</th> <th>Unit</th> <th>Standard value</th> </tr> </thead> <tbody> <tr> <td>00 to 06</td> <td>-</td> <td>00: CMDINH SB SON</td> </tr> </tbody> </table>	Setting range	Unit	Standard value	00 to 06	-	00: CMDINH SB SON
Setting range	Unit	Standard value					
00 to 06	-	00: CMDINH SB SON					
11	Selection						
	00: CMDINH SB SON	PC is inhibited and Servo-Braking is performed. After stops, S-ON is operated.					
	01: CMDINH DB SON	PC is inhibited and Dynamic-Braking is performed. After stops, S-ON is operated.					
	02: CMDINH Free SON	PC is inhibited and Free-Run is performed. After stops, Servo-ON is operated.					
	03: CMDINH SB SOFF	PC is inhibited and Servo-Braking is performed. After stops, S-OFF is operated.					
	04: CMDINH DB SOFF	PC is inhibited and Dynamic-Braking is performed. After stops, S-OFF is operated.					
	05: CMDINH Free SOFF	PC is inhibited and Free-Run is performed. After stops, Servo-OFF is operated.					
06: CMDACK VCLM=0	****						
12	Emergency Stop Operation [ACTEMR]						
	<table border="1"> <thead> <tr> <th>Setting range</th> <th>Unit</th> <th>Standard value</th> </tr> </thead> <tbody> <tr> <td>00 to 01</td> <td>-</td> <td>00: SERVO-BRAKE</td> </tr> </tbody> </table>	Setting range	Unit	Standard value	00 to 01	-	00: SERVO-BRAKE
Setting range	Unit	Standard value					
00 to 01	-	00: SERVO-BRAKE					
12	Selection						
	00: SERVO-BRAKE	When EMR is input, motor is stopped by servo brake operations.					
	01: DINAMIC-BRAKE	When EMR is input, motor is stopped by dynamic brake operations.					

5.Parameter

[Parameter setting value[GroupB]]

Page	Contents							
13	Delay Time of Engaging Holding Brake (holding brake holding delay time) [BONDLY]							
	<table border="1"> <thead> <tr> <th>Setting range</th> <th>Unit</th> <th>Standard value</th> </tr> </thead> <tbody> <tr> <td>0 to 1000</td> <td>ms</td> <td>300</td> </tr> </tbody> </table>	Setting range	Unit	Standard value	0 to 1000	ms	300	Holding brake operation delay time when shifted from servo ON to servo OFF is set. When shifted from servo ON to servo OFF, motor excitation is kept during this time. (Velocity command is Zero.)
Setting range	Unit	Standard value						
0 to 1000	ms	300						
14	Delay Time of Releasing Holding Brake (holding brake release delay time) [BOFFDLY]							
	<table border="1"> <thead> <tr> <th>Setting range</th> <th>Unit</th> <th>Standard value</th> </tr> </thead> <tbody> <tr> <td>0 to 1000</td> <td>ms</td> <td>300</td> </tr> </tbody> </table>	Setting range	Unit	Standard value	0 to 1000	ms	300	Holding brake operation release delay time when shifted from servo OFF to servo ON is set. When shifted from servo OFF to servo ON, motor is excited during this time. (Velocity Command is Zero.)
Setting range	Unit	Standard value						
0 to 1000	ms	300						
15	Brake Operation Beginning Time [BONBGN]							
	<table border="1"> <thead> <tr> <th>Setting range</th> <th>Unit</th> <th>Standard value</th> </tr> </thead> <tbody> <tr> <td>0 to 65535</td> <td>ms</td> <td>0</td> </tr> </tbody> </table>	Setting range	Unit	Standard value	0 to 65535	ms	0	Parameter for setting motor free operation time, dynamic brake operation time and servo brake operation time. When shifted from servo ON to Servo OFF, holding brake and dynamic brake start to operate after this set time. When motor does not stop even after servo OFF at gravity axis or else, motor is stopped by holding brake and dynamic brake. In the system where motor speed becomes lower than Speed Zero Range (ZV) within the set time, this setting does not function. If set to 0msec, brake operation start time is disabled (=infinite).
Setting range	Unit	Standard value						
0 to 65535	ms	0						
16	Power Failure Detection Delay Time [PFDDLY]							
	<table border="1"> <thead> <tr> <th>Setting range</th> <th>Unit</th> <th>Standard value</th> </tr> </thead> <tbody> <tr> <td>20 to 1000</td> <td>ms</td> <td>32</td> </tr> </tbody> </table>	Setting range	Unit	Standard value	20 to 1000	ms	32	The delay time from control power OFF to control power error detection is set. The larger value makes the detection of instantaneous stop slower. (Larger set value will only result in slower detection of error. In case of power failure of internal logic circuit, operation is the same as when control power is turned ON again. In case of energy shortage of main circuit power, other errors, such as main circuit power loss, may be detected.) In this setting, actual detection delay time varies by 12ms and +6ms.  The selected value is enabled after control power is turned ON again.
Setting range	Unit	Standard value						
20 to 1000	ms	32						
20	Following Error Warning Level [OFWL]							
	<table border="1"> <thead> <tr> <th>Setting range</th> <th>Unit</th> <th>Standard value</th> </tr> </thead> <tbody> <tr> <td>1 to 65535</td> <td>×1024 Pulse</td> <td>65535</td> </tr> </tbody> </table>	Setting range	Unit	Standard value	1 to 65535	×1024 Pulse	65535	Parameter to output warning before excessive position deviation alarm (following error) is output.
Setting range	Unit	Standard value						
1 to 65535	×1024 Pulse	65535						
21	Following Error Limit [OFLV]							
	<table border="1"> <thead> <tr> <th>Setting range</th> <th>Unit</th> <th>Standard value</th> </tr> </thead> <tbody> <tr> <td>1 to 65535</td> <td>×1024 Pulse</td> <td>500</td> </tr> </tbody> </table>	Setting range	Unit	Standard value	1 to 65535	×1024 Pulse	500	Parameter for setting the value to output position excessive deviation alarm (following error). Encoder pulse is the standard irrespective of electronic gear and command multiplication function.
Setting range	Unit	Standard value						
1 to 65535	×1024 Pulse	500						

5.Parameter

[Parameter setting value[GroupB]]

Page	Contents												
22	Overload Warning Level [OLWLV]												
	<table border="1" data-bbox="309 315 700 371"> <thead> <tr> <th>Setting range</th> <th>Unit</th> <th>Standard value</th> </tr> </thead> <tbody> <tr> <td>20 to 100</td> <td>%</td> <td>90</td> </tr> </tbody> </table>	Setting range	Unit	Standard value	20 to 100	%	90	<p>Parameter for outputting warnings before overload alarm is output. The possible level to be set is ranged from 20% to 99%, assuming that the overload alarm level is 100%. When set to 100%, overload warning and overload alarm are output at one time.</p> <p>Overload detection is assumed and set as 75% of a rated load when control power is turned ON (hot start). Therefore, if this is set to below 75%, overload warning may be output when control power is turned ON.</p> <p> The set value is enabled after control power is turned ON again.</p>					
Setting range	Unit	Standard value											
20 to 100	%	90											
23	Speed Feedback Error (ALM_C3) Detection [VFBALM]												
	<table border="1" data-bbox="309 669 700 725"> <thead> <tr> <th>Setting range</th> <th>Unit</th> <th>Standard value</th> </tr> </thead> <tbody> <tr> <td>00 to 01</td> <td>-</td> <td>01: _Enabled</td> </tr> </tbody> </table> <table border="1" data-bbox="309 748 572 826"> <thead> <tr> <th>Selection</th> <th>Contents</th> </tr> </thead> <tbody> <tr> <td>00: _Disabled</td> <td>Disabled</td> </tr> <tr> <td>01: _Enabled</td> <td>Enabled</td> </tr> </tbody> </table>	Setting range	Unit	Standard value	00 to 01	-	01: _Enabled	Selection	Contents	00: _Disabled	Disabled	01: _Enabled	Enabled
Setting range	Unit	Standard value											
00 to 01	-	01: _Enabled											
Selection	Contents												
00: _Disabled	Disabled												
01: _Enabled	Enabled												
24	Speed Control Error (ALM_C2) Detection [VCALM]												
	<table border="1" data-bbox="309 909 700 965"> <thead> <tr> <th>Setting range</th> <th>Unit</th> <th>Standard value</th> </tr> </thead> <tbody> <tr> <td>00 to 01</td> <td>-</td> <td>00: _Disabled</td> </tr> </tbody> </table> <table border="1" data-bbox="309 987 572 1066"> <thead> <tr> <th>Selection</th> <th>Contents</th> </tr> </thead> <tbody> <tr> <td>00: _Disabled</td> <td>Disabled</td> </tr> <tr> <td>01: _Enabled</td> <td>Enabled</td> </tr> </tbody> </table>	Setting range	Unit	Standard value	00 to 01	-	00: _Disabled	Selection	Contents	00: _Disabled	Disabled	01: _Enabled	Enabled
Setting range	Unit	Standard value											
00 to 01	-	00: _Disabled											
Selection	Contents												
00: _Disabled	Disabled												
01: _Enabled	Enabled												

5.Parameter

[Parameter setting value[GroupC]]

■ General parameter Group C [Encoder related settings]

Page	Contents						
00	Position detection system choice [ABS/INCSYS]						
	<table border="1"> <thead> <tr> <th>Setting range</th> <th>Unit</th> <th>Standard value</th> </tr> </thead> <tbody> <tr> <td>00 to 01</td> <td>-</td> <td>00: Absolute</td> </tr> </tbody> </table>	Setting range	Unit	Standard value	00 to 01	-	00: Absolute
Setting range	Unit	Standard value					
00 to 01	-	00: Absolute					
01	Motor Incremental Encoder, Digital Filter [ENFIL]						
	<table border="1"> <thead> <tr> <th>Setting range</th> <th>Unit</th> <th>Standard value</th> </tr> </thead> <tbody> <tr> <td>00 to 07</td> <td>-</td> <td>01_220nsec</td> </tr> </tbody> </table>	Setting range	Unit	Standard value	00 to 07	-	01_220nsec
Setting range	Unit	Standard value					
00 to 07	-	01_220nsec					
02	External Encoder, Digital Filter [EX-ENFIL]						
	<table border="1"> <thead> <tr> <th>Setting range</th> <th>Unit</th> <th>Standard value</th> </tr> </thead> <tbody> <tr> <td>00 to 07</td> <td>-</td> <td>01_220nsec</td> </tr> </tbody> </table>	Setting range	Unit	Standard value	00 to 07	-	01_220nsec
Setting range	Unit	Standard value					
00 to 07	-	01_220nsec					
03	External Encoder Polarity Invert [EX-ENPOL]						
	<table border="1"> <thead> <tr> <th>Setting range</th> <th>Unit</th> <th>Standard value</th> </tr> </thead> <tbody> <tr> <td>00 to 07</td> <td>-</td> <td>00: Type1</td> </tr> </tbody> </table>	Setting range	Unit	Standard value	00 to 07	-	00: Type1
Setting range	Unit	Standard value					
00 to 07	-	00: Type1					

Selection	Contents		
00: 110nsec	Minimum Pulse Width = 110nsec (Minimum Pulse Phase Difference = 37.5nsec)		
01: 220nsec	Minimum Pulse Width = 220nsec		
02: 440nsec	Minimum Pulse Width = 440nsec		
03: 880nsec	Minimum Pulse Width = 880nsec		
04: 75nsec	Minimum Pulse Width = 75nsec (Minimum Pulse Phase Difference = 37.5nsec)		
05: 150nsec	Minimum Pulse Width = 150nsec		
06: 300nsec	Minimum Pulse Width = 300nsec		
07: 600nsec	Minimum Pulse Width = 600nsec		

Selection	Contents		
00: 110nsec	Minimum pulse width=110nsec (Minimum phase difference=37.5nsec)		
01: 220nsec	Minimum pulse width=220nsec		
02: 440nsec	Minimum pulse width=440nsec		
03: 880nsec	Minimum pulse width=880nsec		
04: 75nsec	Minimum pulse width=75nsec (Minimum phase difference=37.5nsec)		
05: 150nsec	Minimum pulse width=150nsec		
06: 300nsec	Minimum pulse width=300nsec		
07: 600nsec	Minimum pulse width=600nsec		



Selection	Contents		
00: Type1	EX-Z (S3)/ Not Reversed	EX-B (S2)/ Not Reversed	EX-A (S1)/ Not Reversed
01: Type2	EX-Z (S3)/ Not Reversed	EX-B (S2)/ Not Reversed	EX-A (S1)/ Reversed
02: Type3	EX-Z (S3)/ Not Reversed	EX-B (S2)/ Reversed	EX-A (S1)/ Not Reversed
03: Type4	EX-Z (S3)/ Not Reversed	EX-B (S2)/ Reversed	EX-A (S1)/ Reversed
04: Type5	EX-Z (S3)/ Reversed	EX-B (S2)/ Not Reversed	EX-A (S1)/ Not Reversed
05: Type6	EX-Z (S3)/ Reversed	EX-B (S2)/ Not Reversed	EX-A (S1)/ Reversed
06: Type7	EX-Z (S3)/ Reversed	EX-B (S2)/ Reversed	EX-A (S1)/ Not Reversed
07: Type8	EX-Z (S3)/ Reversed	EX-B (S2)/ Reversed	EX-A (S1)/ Reversed

Fully-closed control

Fully-closed control

5.Parameter

[Parameter setting value[GroupC]]

Page	Contents								
04	Encoder Pulse Divided Output, Selection [PULOUTSEL]								
	<table border="1"> <thead> <tr> <th>Setting range</th> <th>Unit</th> <th>Standard value</th> </tr> </thead> <tbody> <tr> <td>00 to 01</td> <td>-</td> <td>00: Motor_Enc.</td> </tr> </tbody> </table>	Setting range	Unit	Standard value	00 to 01	-	00: Motor_Enc.	Encoder pulse division output signal is selected from the contents below.	
Setting range	Unit	Standard value							
00 to 01	-	00: Motor_Enc.							
05	Encoder Output Pulse, Divide Ratio [ENRAT]								
	<table border="1"> <thead> <tr> <th>Setting range</th> <th>Unit</th> <th>Standard value</th> </tr> </thead> <tbody> <tr> <td>1/1 to 1/64</td> <td rowspan="3">-</td> <td rowspan="3">1/1</td> </tr> <tr> <td>2/3 to 2/64</td> </tr> <tr> <td>1/8192 to 8191/8192</td> </tr> </tbody> </table>	Setting range	Unit	Standard value	1/1 to 1/64	-	1/1	2/3 to 2/64	1/8192 to 8191/8192
Setting range	Unit	Standard value							
1/1 to 1/64	-	1/1							
2/3 to 2/64									
1/8192 to 8191/8192									
06	Encoder Pulse Divided output, Polarity [PULOUTPOL]								
	<table border="1"> <thead> <tr> <th>Setting range</th> <th>Unit</th> <th>Standard value</th> </tr> </thead> <tbody> <tr> <td>00 to 03</td> <td>-</td> <td>00: Type1</td> </tr> </tbody> </table>	Setting range	Unit	Standard value	00 to 03	-	00: Type1	Encoder pulse dividing output polarity is selected from the followings.	
Setting range	Unit	Standard value							
00 to 03	-	00: Type1							
07	Encoder Signal Output (PS), Format [PSOFORM]								
	<table border="1"> <thead> <tr> <th>Setting range</th> <th>Unit</th> <th>Standard value</th> </tr> </thead> <tbody> <tr> <td>00 to 02</td> <td>-</td> <td>00: Binary</td> </tr> </tbody> </table>	Setting range	Unit	Standard value	00 to 02	-	00: Binary	Signal format of encoder signal output (PS) is selected from the followings.  The set value is enabled after control power is turned ON again.	
Setting range	Unit	Standard value							
00 to 02	-	00: Binary							
08	Abusolute Encoder Clear Function Selection [ECLRFUNC]								
	<table border="1"> <thead> <tr> <th>Setting range</th> <th>Unit</th> <th>Standard value</th> </tr> </thead> <tbody> <tr> <td>00 to 01</td> <td>-</td> <td>00: Status_MultiTurn</td> </tr> </tbody> </table>	Setting range	Unit	Standard value	00 to 01	-	00: Status_MultiTurn	Used for clearing some absolute encoder warnings which are not automatically restored.  Valid when battery backup method absolute encoder and absolute encoder without battery is used.  Please set it to "01: Status" when you use absolute encoder for incremental system.	
Setting range	Unit	Standard value							
00 to 01	-	00: Status_MultiTurn							
<table border="1"> <thead> <tr> <th>Selection</th> <th>Contents</th> </tr> </thead> <tbody> <tr> <td>00: Status_MultiTurn</td> <td>Clear Encoder Status (Alarm and Warning) and Multi Turn Data</td> </tr> <tr> <td>01: Status</td> <td>Clear Only Encoder Status</td> </tr> </tbody> </table>		Selection	Contents	00: Status_MultiTurn	Clear Encoder Status (Alarm and Warning) and Multi Turn Data	01: Status	Clear Only Encoder Status		
Selection	Contents								
00: Status_MultiTurn	Clear Encoder Status (Alarm and Warning) and Multi Turn Data								
01: Status	Clear Only Encoder Status								

Fully-closed control

5.Parameter [Parameter setting value [system parameter]]

System parameters

Page	Description																									
00	Main Power, Input Type	Selects the input mode for power supplied to the main circuit power supply. Setting range varies depending on the hardware type.																								
	<table border="1"> <thead> <tr> <th>Setting value</th> <th>Description</th> </tr> </thead> <tbody> <tr> <td>00: AC_3-phase</td> <td>3 phaseAC power is supplied to the main circuit.</td> </tr> <tr> <td>01: AC_Single-phase</td> <td>Single phaseAC power is supplied to the main circuit.</td> </tr> </tbody> </table>		Setting value	Description	00: AC_3-phase	3 phaseAC power is supplied to the main circuit.	01: AC_Single-phase	Single phaseAC power is supplied to the main circuit.																		
	Setting value	Description																								
00: AC_3-phase	3 phaseAC power is supplied to the main circuit.																									
01: AC_Single-phase	Single phaseAC power is supplied to the main circuit.																									
Motor Encoder Type	Motor encoder type in use is selected. Setting range varies depending on the hardware type.																									
01	<table border="1"> <thead> <tr> <th>Setting value</th> <th>Description</th> </tr> </thead> <tbody> <tr> <td>00: _Incremental_ENC</td> <td>Incremental Encoder</td> </tr> <tr> <td>01: _Absolute_ENC</td> <td>Absolute Encoder</td> </tr> </tbody> </table>		Setting value	Description	00: _Incremental_ENC	Incremental Encoder	01: _Absolute_ENC	Absolute Encoder																		
	Setting value	Description																								
	00: _Incremental_ENC	Incremental Encoder																								
01: _Absolute_ENC	Absolute Encoder																									
Incremental Encoder, Function Setting	Incremental encoder type is selected when an incremental encoder is used for the motor encoder. Setting range varies depending on the hardware type.																									
02	<table border="1"> <thead> <tr> <th>Setting value</th> <th>Description</th> </tr> </thead> <tbody> <tr> <td>00: Standard</td> <td>Wiring-Save Incremental Encoder [Standard (4-Pairs)]</td> </tr> <tr> <td>01: _7Pairs_INC-E</td> <td>Incremental Encoder with CS Signal. [7-Pairs]</td> </tr> </tbody> </table>		Setting value	Description	00: Standard	Wiring-Save Incremental Encoder [Standard (4-Pairs)]	01: _7Pairs_INC-E	Incremental Encoder with CS Signal. [7-Pairs]																		
	Setting value	Description																								
	00: Standard	Wiring-Save Incremental Encoder [Standard (4-Pairs)]																								
01: _7Pairs_INC-E	Incremental Encoder with CS Signal. [7-Pairs]																									
Incremental Encoder, Resolution Setting	Pulse number per motor shaft rotation is set when an incremental encoder is used for the motor encoder.																									
03	<table border="1"> <thead> <tr> <th>Setting range</th> <th>Unit</th> <th>Standard value</th> </tr> </thead> <tbody> <tr> <td>500 to 65535</td> <td>P/R</td> <td>-</td> </tr> </tbody> </table>		Setting range	Unit	Standard value	500 to 65535	P/R	-																		
	Setting range	Unit	Standard value																							
500 to 65535	P/R	-																								
Absolute Encoder, Function Setting	Absolute encoder type is selected when an absolute encoder is used for the motor encoder. Setting range varies depending on the hardware type. Can only be selected when 01: _Absolute_ENC is selected at Page01 (motor encoder type).																									
04	<table border="1"> <thead> <tr> <th>Setting</th> <th>Description</th> </tr> </thead> <tbody> <tr> <td>04: _PA035C-2.5MH_Manu</td> <td>PA035C, PA035S, Asynchronous, 2.5Mbps, Half Duplex (Manual Setting)</td> </tr> <tr> <td>05: _PA035C-4MH_Manu</td> <td>PA035C, PA035S, Asynchronous, 4Mbps, Half Duplex (Manual Setting)</td> </tr> <tr> <td>06: _RA062C-2.5MH_Manu</td> <td>RA062C, Asynchronous, 2.5Mbps, Half Duplex (Manual Setting)</td> </tr> <tr> <td>07: _RA062C-4MH_Manu</td> <td>RA062C, Asynchronous, 4Mbps, Half Duplex (Manual Setting)</td> </tr> <tr> <td>80: RA062M-1MF</td> <td>RA062M, Manchester, 1Mbps, Full Duplex</td> </tr> <tr> <td>81: RA062M-2MF</td> <td>RA062M, Manchester, 2Mbps, Full Duplex</td> </tr> <tr> <td>84: _ABS-E</td> <td>ABS-E, 1Mbps (Absolute Encoder with Incremental Signal)</td> </tr> </tbody> </table>		Setting	Description	04: _PA035C-2.5MH_Manu	PA035C, PA035S, Asynchronous, 2.5Mbps, Half Duplex (Manual Setting)	05: _PA035C-4MH_Manu	PA035C, PA035S, Asynchronous, 4Mbps, Half Duplex (Manual Setting)	06: _RA062C-2.5MH_Manu	RA062C, Asynchronous, 2.5Mbps, Half Duplex (Manual Setting)	07: _RA062C-4MH_Manu	RA062C, Asynchronous, 4Mbps, Half Duplex (Manual Setting)	80: RA062M-1MF	RA062M, Manchester, 1Mbps, Full Duplex	81: RA062M-2MF	RA062M, Manchester, 2Mbps, Full Duplex	84: _ABS-E	ABS-E, 1Mbps (Absolute Encoder with Incremental Signal)								
	Setting	Description																								
	04: _PA035C-2.5MH_Manu	PA035C, PA035S, Asynchronous, 2.5Mbps, Half Duplex (Manual Setting)																								
	05: _PA035C-4MH_Manu	PA035C, PA035S, Asynchronous, 4Mbps, Half Duplex (Manual Setting)																								
	06: _RA062C-2.5MH_Manu	RA062C, Asynchronous, 2.5Mbps, Half Duplex (Manual Setting)																								
	07: _RA062C-4MH_Manu	RA062C, Asynchronous, 4Mbps, Half Duplex (Manual Setting)																								
	80: RA062M-1MF	RA062M, Manchester, 1Mbps, Full Duplex																								
81: RA062M-2MF	RA062M, Manchester, 2Mbps, Full Duplex																									
84: _ABS-E	ABS-E, 1Mbps (Absolute Encoder with Incremental Signal)																									
Absolute Encoder, Resolution Setting	Divisions per motor shaft rotation are set when absolute encoder is used for the motor encoder. Can only be selected when 01: _Absolute_ENC is selected at Page01 (motor encoder type).																									
05	<table border="1"> <thead> <tr> <th>Setting</th> <th>Description</th> </tr> </thead> <tbody> <tr> <td>00: 2048_FMT</td> <td>2048 divisions</td> </tr> <tr> <td>01: 4096_FMT</td> <td>4096 divisions</td> </tr> <tr> <td>02: 8192_FMT</td> <td>8192 divisions</td> </tr> <tr> <td>03: 16384_FMT</td> <td>16384 divisions</td> </tr> <tr> <td>04: 32768_FMT</td> <td>32768 divisions</td> </tr> <tr> <td>05: 65536_FMT</td> <td>65536 divisions</td> </tr> <tr> <td>06: 131072_FMT</td> <td>131072 divisions</td> </tr> <tr> <td>07: 262144_FMT</td> <td>262144 divisions</td> </tr> <tr> <td>08: 524288_FMT</td> <td>524288 divisions</td> </tr> <tr> <td>09: 1048576_FMT</td> <td>1048576 divisions</td> </tr> <tr> <td>0A: 2097152_FMT</td> <td>2097152 divisions</td> </tr> </tbody> </table>		Setting	Description	00: 2048_FMT	2048 divisions	01: 4096_FMT	4096 divisions	02: 8192_FMT	8192 divisions	03: 16384_FMT	16384 divisions	04: 32768_FMT	32768 divisions	05: 65536_FMT	65536 divisions	06: 131072_FMT	131072 divisions	07: 262144_FMT	262144 divisions	08: 524288_FMT	524288 divisions	09: 1048576_FMT	1048576 divisions	0A: 2097152_FMT	2097152 divisions
	Setting	Description																								
	00: 2048_FMT	2048 divisions																								
	01: 4096_FMT	4096 divisions																								
	02: 8192_FMT	8192 divisions																								
	03: 16384_FMT	16384 divisions																								
	04: 32768_FMT	32768 divisions																								
	05: 65536_FMT	65536 divisions																								
	06: 131072_FMT	131072 divisions																								
	07: 262144_FMT	262144 divisions																								
	08: 524288_FMT	524288 divisions																								
09: 1048576_FMT	1048576 divisions																									
0A: 2097152_FMT	2097152 divisions																									

5.Parameter [Parameter setting value [system parameter]]

Page	Description																
06	Combined motor model number Note 1)	In "The set up software", model numbers of combined motor and their codes are shown. When combined motor is to be changed, change the motor parameter setting of "The set up software". Page contents are different for digital operator. Refer to Note 1).															
08	Control Mode	Selects control mode.															
	<table border="1" style="width:100%"> <thead> <tr> <th>Setting</th> <th>Description</th> <th>Setting</th> <th>Description</th> </tr> </thead> <tbody> <tr> <td>00: _Torque</td> <td>Torque Control Mode</td> <td>03: _Velo-Torq</td> <td>Velocity-Torque Switch Mode</td> </tr> <tr> <td>01: _Velocity</td> <td>Velocity Control Mode</td> <td>04: _Posi-Torq</td> <td>Position-Torque Switch Mode</td> </tr> <tr> <td>02: _Position</td> <td>Position Control Mode</td> <td>05: _Posi-Velo</td> <td>Position-Velocity Switch Mode</td> </tr> </tbody> </table> When the switching type between [03: _Velo-Torq] [04: _Posi-Torq] and [05: _Posi-Velo] is used, there is a possibility that "auto-notch frequency tuning", "auto-vibration suppressing frequency tuning" and "JOG operation" cannot be used. To use these, switch the control mode to the base side (velocity control) in case of [03: _Velo-Torq]).	Setting	Description	Setting	Description	00: _Torque	Torque Control Mode	03: _Velo-Torq	Velocity-Torque Switch Mode	01: _Velocity	Velocity Control Mode	04: _Posi-Torq	Position-Torque Switch Mode	02: _Position	Position Control Mode	05: _Posi-Velo	Position-Velocity Switch Mode
Setting	Description	Setting	Description														
00: _Torque	Torque Control Mode	03: _Velo-Torq	Velocity-Torque Switch Mode														
01: _Velocity	Velocity Control Mode	04: _Posi-Torq	Position-Torque Switch Mode														
02: _Position	Position Control Mode	05: _Posi-Velo	Position-Velocity Switch Mode														
09	Position Loop Control and Position Loop Encoder Selection	Position loop encoder is selected used for position loop control method and position loop control. Setting range varies depending on the hardware type.															
	<table border="1" style="width:100%"> <thead> <tr> <th>Setting</th> <th>Description</th> </tr> </thead> <tbody> <tr> <td>00: _Motor_encoder</td> <td>Semi-Closed Control / Motor Encoder</td> </tr> <tr> <td>01: _Ext-ENC</td> <td>Fully Closed Control / External Encoder</td> </tr> </tbody> </table> <div style="text-align:right; background-color:#cccccc; padding:5px; border-radius:10px;">Fully-closed control</div>	Setting	Description	00: _Motor_encoder	Semi-Closed Control / Motor Encoder	01: _Ext-ENC	Fully Closed Control / External Encoder										
Setting	Description																
00: _Motor_encoder	Semi-Closed Control / Motor Encoder																
01: _Ext-ENC	Fully Closed Control / External Encoder																
0A	External Encoder, Resolution Setting	Sets the resolution of the external encoder under full closed control. Sets the number of converted pulses for each rotation of the motor shaft.															
	<table border="1" style="width:100%"> <thead> <tr> <th>Setting range</th> <th>Unit</th> <th>Standard value</th> </tr> </thead> <tbody> <tr> <td>500 to 65535</td> <td>P/R</td> <td>-</td> </tr> </tbody> </table> <div style="text-align:right; background-color:#cccccc; padding:5px; border-radius:10px;">Fully-closed control</div> Example: <ul style="list-style-type: none"> ◆ The minimum resolution of the External pulse encoder to be used: 1.0μm ◆ Work moving distance of 1 rotation of the motor axis: 10mm External pulse encoder minimum resolution: 1.0μm >> converted pulse number per 1mm > >1000P/mm. Converted pulse number per 1mm from the External pulse encoder's minimum resolution: 1mm becomes 1000P/mm. 10mm/1R×1000P/mm=10000P/R (4x multiplier), since the moving distance of work for 1 motor axis is 10 mm. Set: 10000/4=2500P/R (setting value is 1x multiplier) Round off decimals. ✓ Please round off the value below a decimal point.	Setting range	Unit	Standard value	500 to 65535	P/R	-										
Setting range	Unit	Standard value															
500 to 65535	P/R	-															
0B	Regenerative Resistor Selection	Selects the type of regenerative resistance to be connected.															
	<table border="1" style="width:100%"> <thead> <tr> <th>Setting</th> <th>Description</th> </tr> </thead> <tbody> <tr> <td>00: _Not_connect</td> <td>Regenerative Resistor is not Connected</td> </tr> <tr> <td>01: _Built-in_R</td> <td>Use Built-In Regenerative Resistor</td> </tr> <tr> <td>02: _External_R</td> <td>Use External Regenerative Resistor</td> </tr> </tbody> </table>	Setting	Description	00: _Not_connect	Regenerative Resistor is not Connected	01: _Built-in_R	Use Built-In Regenerative Resistor	02: _External_R	Use External Regenerative Resistor								
Setting	Description																
00: _Not_connect	Regenerative Resistor is not Connected																
01: _Built-in_R	Use Built-In Regenerative Resistor																
02: _External_R	Use External Regenerative Resistor																

The set value is enabled after control power is turned ON again.

Note) In case of digital operator

Page	Description	
06	Servo amplifier information	This is for maker maintenance.
07	Combined motor code	In the digital operator, motor codes of the selected servo motor are displayed. To change the combined motor, change the motor parameter setting at "The set up software". Combined motor cannot be changed by the digital operator.

5.Parameter

[Block diagram]

R Series Servo Amplifier Control Block Chart

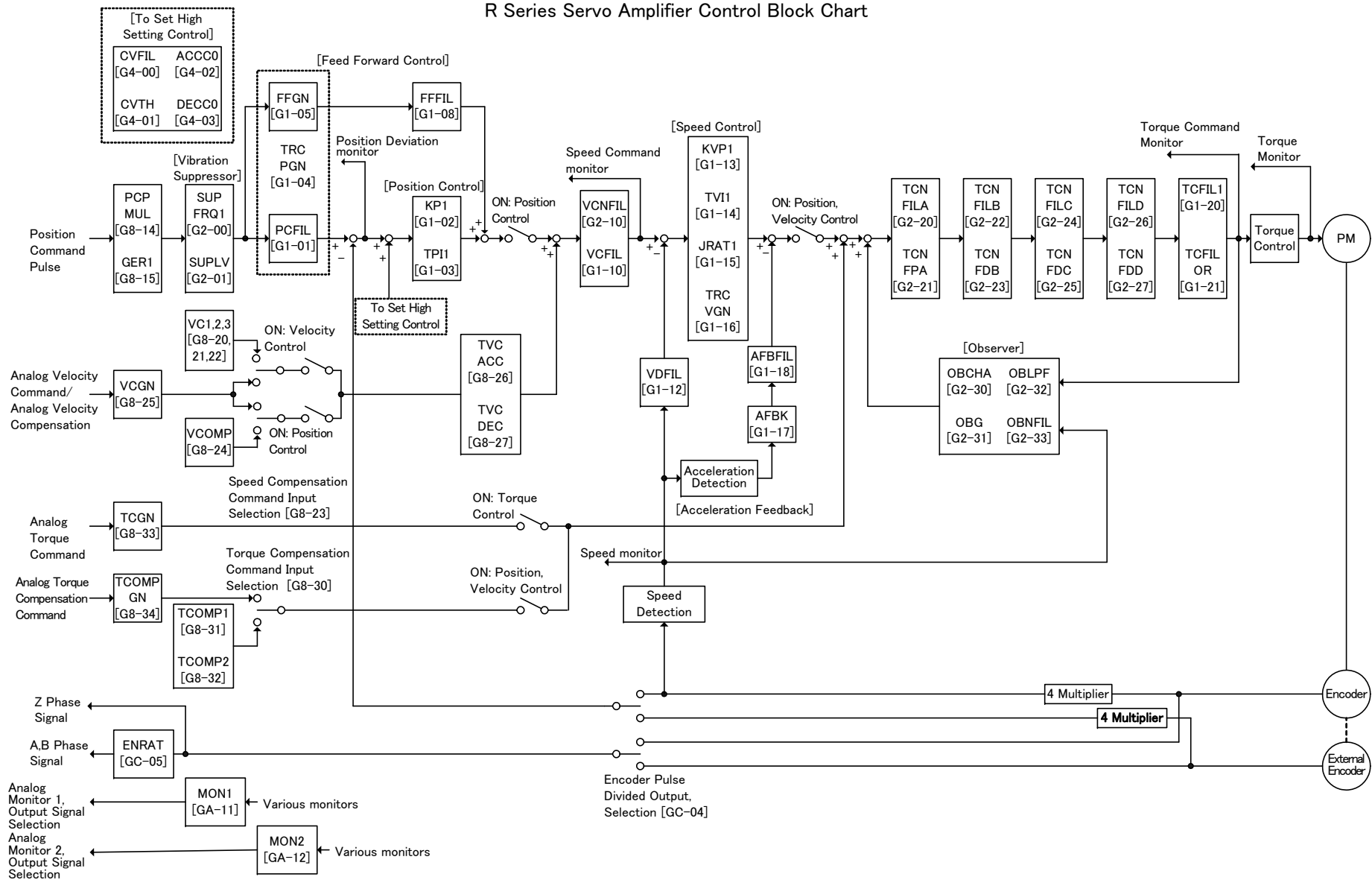

No Text on This Page.

[Operations]

◆	Procedure prior to operation	6-1
◆	Confirmation of Installation and Wiring	6-3
◆	Confirmation & Change of servo amplifier specification	6-4
◆	Confirmation & Change of servo motor encoder specification	6-5
◆	Confirmation & Change of servo motor model number	6-6
◆	JOG operation	6-7
◆	Confirmation of I/O signal	6-8
◆	Confirmation of device operation	6-9
◆	Operation sequence	6-10

6.Operations

[Procedure prior to operation]

- After wiring, test run will begin. Please do not connect the shaft of the servo motor with the machine.
- Confirm installation and wiring of the servo amplifier and servo motor.

[Confirmation of installation and wiring]

Procedure	Item	Contents
1	Installation	Referring to [Chapter 2. Installation], install the servo amplifier and the servo motor. Do not connect the shaft of the servo motor into the machine to keep the status of no load.
2	Wiring and connection	Referring to [Chapter 3. Wiring], perform wirings for the power supply, the servo motor, and the upper device. However, please do not connect CN1 with the servo amplifier after wiring has been done.
3	Power supply turning on	Please turn on the power supply. Please confirm the alarm code is not being displayed at a digital operator of the servo amplifier. When it is displayed, follow the instructions in [Chapter 8 Maintenance]. Alarm A2 may flash when initially turning on the power supply after wiring servo amplifier and servo motor with battery-backup absolute encoder. This is for the following reasons: The back-up available time covered by battery has elapsed, this should make the absolute position inside of encoder unstable, and then the alarm should be output in line with the state.

- Confirm the specifications and the combination of the servo amplifier servo motor encoders.

[Confirmation and Change of specification]

Procedure	Item	Contents
4	Confirmation of servo amplifier specification	Use the AC servo system supporting tool R-Setup to confirm and set the specifications of the servo amplifier. <ul style="list-style-type: none"> • Amplifier Capacity • Control power supply input voltage • Control power supply input type • Main circuit power supply input voltage • Main Power, Input Type • Control mode • Encoder selection for full close control • Regenerative Resistor Selection
5	Confirmation of servo motor encoder specification	Use the AC servo system supporting tool R-Setup to confirm and set the specifications of the servo motor encoder. <ul style="list-style-type: none"> • Motor Encoder Type • Incremental encoder function selection • Incremental Encoder, Resolution Setting • Absolute encoder function selection • Absolute Encoder, Resolution Setting • Confirmation of external encoder specification
6	Confirmation of combined servo motor	At the time of shipment, the smallest servo motor is combined with the servo amplifier of each capacity. Confirm the servo motor model number and change the parameter for the one in use.
7	Power supply re-turning on	Turn off the power once and turn it on again. Parameter will have been changed by turning off the power supply. Without turning off the power, even if a parameter is changed here, the parameter change will not complete.
8	Reconfirmation	Please check again the specification changes of servo amplifier and servo encoder, and combination with servo motor. Many of the troubles at test run, such as servo motor not operating, are caused by mistakes in parameter setting.

6.Operations

[Procedure prior to operation]

- The movement of the servo amplifier servo motor is confirmed by driving JOG. [JOG driving]

Procedure	Item	Contents
9	JOG driving	Do not connect the shaft of the servo motor into the machine to keep the status of no load, and perform JOG operation. Confirm that the servo motor rotates forwards and backwards.

- Connect the upper device with CN1, and set the parameter of the I/O signal. [I/O signal confirmation]

Procedure	Item	Contents
10	Setting of generic I/O signal	The generic I/O signal (CN1) has been set to standard at the time of shipment. Set I/O signals necessary to the servo amplifier.
11	Confirmation of input signal	Confirm the I/O signal status using the monitoring function inside the servo amplifier. Please confirm that there are protecting functions such as emergency stop, over travel, and alarm reset.
12	The servo on signal is input.	The servo on signal is input, and the servo motor is excited. Please confirm the digital operator on the servo amplifier front is displaying a shape of "8".
13	Command input	Input the command matched with the control mode in use. Confirm the command input at the servo amplifier monitoring function. Confirm that command input and the rotation direction are correct.
14	Power supply shut off	After the servo on signal is turned off, turn the power supply off.

- Connect the servo motor shaft with the machine and confirm the operation.

[Confirmation of machine's operation function]

Procedure	Item	Contents
15	Command input (low-speed)	Input the command (low-speed) matched with the control mode in use. Confirm the normal operation of moving direction, moving distance, emergency stop, over travel (F-OT·R-OT), etc.

- Input the operation pattern in use and start to operate the machine.

[Operation]

Procedure	Item	Contents
16	Operation	At the time of shipment, real time auto-tuning (automatic adjustment for servo gain and filter) has been set. There is no need for manual tuning unless operations and characteristics are appropriate.

So far, overall procedure is shown.

More detailed procedure is described in the following pages.

6.Operations

[Confirmation of installation and wiring]

■ [Procedure 1 to Procedure 3] Confirmation of installation and wiring

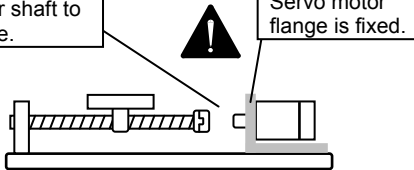
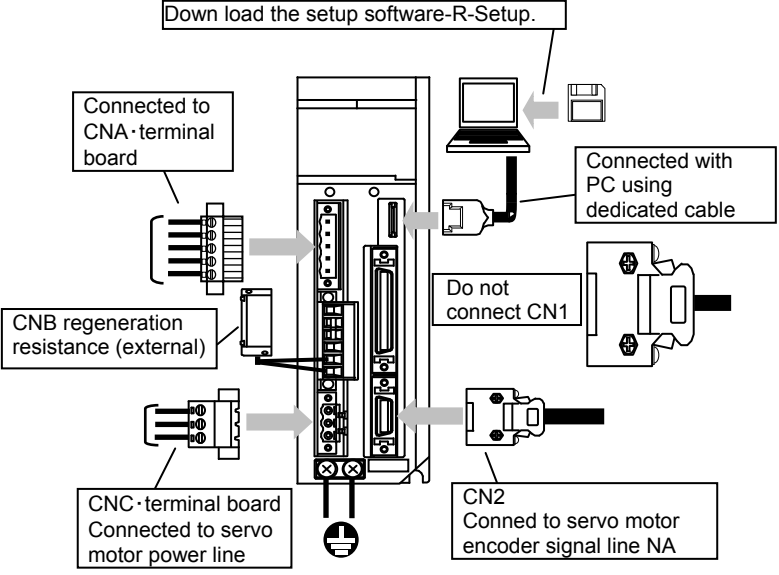
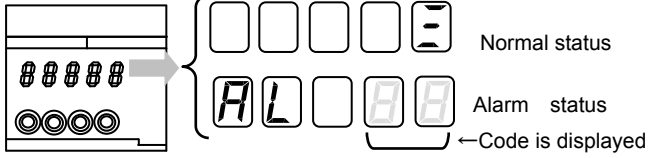
Procedure	Item	Contents
1	<p><u>Installation</u></p> <p>Install the servo amplifier and servo motor referring to [Chapter 2, Installation].</p> <p>Do not connect the servo motor shaft to the machine to keep the status of no load.</p>	<p>Do not connect the servo motor shaft to the machine.</p> <p>Servo motor flange is fixed.</p> 
2	<p><u>Wiring and connection</u></p> <p>Wire the power supply, servo motor and upper device referring to [Chapter 3, Wiring].</p> <p>Confirm the correct wiring.</p> <p>If the servo motor does not rotate or is in a state of runaway / overload in test run, wrong wiring may be the cause of it.</p> <p>Do not connect CN1 to servo amplifier after wiring.</p>	<p>Down load the setup software-R-Setup.</p> 
3	<p><u>Turning on the power supply</u></p> <p>Turn on the power supply. Confirm that there is no alarm code displayed on the digital operator of servo amplifier. If there is one, follow the instructions in [Chapter 8, Maintenance].</p>	

6.Operations

[Confirmation of installation and wiring]

■ [Procedure4 to Procedure8]

Confirming specifications and combination of servo amplifier·servo motor·encoder

Procedure	Item and Contents														
4	<p>Confirming servo amplifier specifications System parameter settings</p> <p>Use the AC servo system supporting tool R-Setup to confirm and set the specifications of the servo amplifier. For how to use [the setup software R-Setup], refer to [R-SETUP Instruction Manual].</p>														
	Item														
	<p>Amplifier capacity</p> <p>Capacity of the servo amplifier.</p>	<p>Setting cannot be changed.</p> <p>Make sure that the contents being displayed are suitable for the machine specifications.</p>													
	<p>Motor motion</p> <p>Structure of the motor that can be combined.</p>														
	<p>Control power input voltage</p> <p>Voltage to be supplied to the control power.</p>														
	<p>Input type of control power supply</p> <p>Input type of the control power supply.</p>														
	<p>Main power, Input voltage</p> <p>Power voltage to be supplied to main circuit.</p>														
	<p>Main power, Input type</p> <p>Selects the input type supplied to main circuit power. Change the set value to 01: _AC_Single-phase for single phase use.</p>	<table border="1" style="width: 100%;"> <thead> <tr> <th style="width: 30%;">Set value</th> <th>Contents</th> </tr> </thead> <tbody> <tr> <td>00:_AC_3-phase</td> <td>Provide 3-phase AC Power Supply to the Main Power Supply</td> </tr> <tr> <td>01:_AC_Single-phase</td> <td>Provide Single-Phase AC Power Supply to the Main Power Supply</td> </tr> </tbody> </table>	Set value	Contents	00:_AC_3-phase	Provide 3-phase AC Power Supply to the Main Power Supply	01:_AC_Single-phase	Provide Single-Phase AC Power Supply to the Main Power Supply							
Set value	Contents														
00:_AC_3-phase	Provide 3-phase AC Power Supply to the Main Power Supply														
01:_AC_Single-phase	Provide Single-Phase AC Power Supply to the Main Power Supply														
<p>Control mode</p> <p>Selects the control mode. Change the control mode suitable for upper device.</p>	<table border="1" style="width: 100%;"> <thead> <tr> <th style="width: 30%;">Setting</th> <th>Contents</th> </tr> </thead> <tbody> <tr> <td>00:_Torque</td> <td>Torque Control Mode</td> </tr> <tr> <td>01:_Velocity</td> <td>Velocity Control Mode</td> </tr> <tr> <td>02:_Position</td> <td>Position Control Mode</td> </tr> <tr> <td>03:_Velo—Torq</td> <td>Velocity - Torque Switch Mode</td> </tr> <tr> <td>04:_Posi—Torq</td> <td>Position - Torque Switch Mode</td> </tr> <tr> <td>05:_Posi—Velo</td> <td>Position - Velocity Switch Mode</td> </tr> </tbody> </table>	Setting	Contents	00:_Torque	Torque Control Mode	01:_Velocity	Velocity Control Mode	02:_Position	Position Control Mode	03:_Velo—Torq	Velocity - Torque Switch Mode	04:_Posi—Torq	Position - Torque Switch Mode	05:_Posi—Velo	Position - Velocity Switch Mode
Setting	Contents														
00:_Torque	Torque Control Mode														
01:_Velocity	Velocity Control Mode														
02:_Position	Position Control Mode														
03:_Velo—Torq	Velocity - Torque Switch Mode														
04:_Posi—Torq	Position - Torque Switch Mode														
05:_Posi—Velo	Position - Velocity Switch Mode														
<p>Fully-closed control encoder selection</p> <p>No change is necessary for other than full closed system. Confirm that this is set to standard value, at the time of shipment, of 00: _Motor_encoder.</p>	<p>This is to be set when the system is full closed control.</p> <table border="1" style="width: 100%;"> <thead> <tr> <th style="width: 30%;">Setting</th> <th>Contents</th> </tr> </thead> <tbody> <tr> <td>00: _Motor_encoder</td> <td>Semi-Closed Control / Motor Encoder</td> </tr> <tr> <td>01: _Ext—ENC</td> <td>Fully Closed Control / External Encoder</td> </tr> </tbody> </table>	Setting	Contents	00: _Motor_encoder	Semi-Closed Control / Motor Encoder	01: _Ext—ENC	Fully Closed Control / External Encoder								
Setting	Contents														
00: _Motor_encoder	Semi-Closed Control / Motor Encoder														
01: _Ext—ENC	Fully Closed Control / External Encoder														
<p>Regenerative resistor selection</p> <p>Selects the regeneration resistance to be connected.</p>	<table border="1" style="width: 100%;"> <thead> <tr> <th style="width: 30%;">Setting</th> <th>Contents</th> </tr> </thead> <tbody> <tr> <td>00: Not_connect</td> <td>Regenerative Resistor is not Connected</td> </tr> <tr> <td>01: Built-in_R</td> <td>Use Built-In Regenerative Resistor</td> </tr> <tr> <td>02: External_R</td> <td>Use External Regenerative Resistor</td> </tr> </tbody> </table>	Setting	Contents	00: Not_connect	Regenerative Resistor is not Connected	01: Built-in_R	Use Built-In Regenerative Resistor	02: External_R	Use External Regenerative Resistor						
Setting	Contents														
00: Not_connect	Regenerative Resistor is not Connected														
01: Built-in_R	Use Built-In Regenerative Resistor														
02: External_R	Use External Regenerative Resistor														

6.Operations [Confirmation & Change of servo motor encoder specification]

Procedure	Item and Contents																																																																													
5	<p data-bbox="252 282 1489 315">Confirming servo motor encoder specifications System parameter setting</p> <p data-bbox="252 327 1489 389">Use the AC servo system supporting tool R-Setup to confirm and set the specifications of the encoder. For how to use [the setup software R-Setup], refer to [R-SETUP Instruction Manual].</p> <table border="1" data-bbox="252 394 1489 2000"> <thead> <tr> <th data-bbox="252 394 738 427">Item</th> <th colspan="2" data-bbox="738 394 1489 427"></th> </tr> </thead> <tbody> <tr> <td data-bbox="252 432 738 600"> <p data-bbox="252 432 738 465">Motor encoder type</p> <p data-bbox="252 472 738 506">Selects the servo motor encoder type.</p> </td> <td colspan="2" data-bbox="738 432 1489 600"> <table border="1" data-bbox="754 461 1481 577"> <thead> <tr> <th data-bbox="754 461 1010 495">Setting value</th> <th data-bbox="1010 461 1481 495">Contents</th> </tr> </thead> <tbody> <tr> <td data-bbox="754 506 1010 539">00:_Incremental_ENC</td> <td data-bbox="1010 506 1481 539">Incremental Encoder</td> </tr> <tr> <td data-bbox="754 546 1010 580">01:_Absolute_ENC</td> <td data-bbox="1010 546 1481 580">Absolute Encoder</td> </tr> </tbody> </table> </td> </tr> <tr> <td data-bbox="252 604 738 831"> <p data-bbox="252 604 738 638">Incremental encoder, function setting</p> <p data-bbox="252 645 738 707">Selects detailed function of incremental encoder.</p> </td> <td colspan="2" data-bbox="738 604 1489 831"> <p data-bbox="738 604 1489 667">This is set when motor encoder type is “incremental encoder”.</p> <table border="1" data-bbox="754 667 1481 824"> <thead> <tr> <th data-bbox="754 667 1010 701">Setting value</th> <th data-bbox="1010 667 1481 701">Contents</th> </tr> </thead> <tbody> <tr> <td data-bbox="754 712 1010 775">00:_Standard</td> <td data-bbox="1010 712 1481 775">Wiring-Save Incremental Encoder [Standard (4-Pairs)]</td> </tr> <tr> <td data-bbox="754 781 1010 815">01:_7pairs_INC-E</td> <td data-bbox="1010 781 1481 815">Incremental Encoder with CS Signal. [7-Pairs]</td> </tr> </tbody> </table> </td> </tr> <tr> <td data-bbox="252 835 738 898"> <p data-bbox="252 835 738 869">Incremental encoder, resolution setting</p> <p data-bbox="252 875 738 909">Sets the incremental encoder resolution.</p> </td> <td colspan="2" data-bbox="738 835 1489 898"> <p data-bbox="738 835 1489 898">Sets the pulse number of motor shaft one rotation. 500P/R to 65535P/R Setting unit=Pulse/Rev.</p> </td> </tr> <tr> <td data-bbox="252 902 738 1462"> <p data-bbox="252 902 738 936">Absolute encoder, function setting</p> <p data-bbox="252 943 738 1005">Selects detailed function of absolute encoder.</p> </td> <td colspan="2" data-bbox="738 902 1489 1462"> <p data-bbox="738 902 1489 965">This is set when the motor encoder type is “absolute encoder”.</p> <table border="1" data-bbox="754 965 1481 1451"> <thead> <tr> <th data-bbox="754 965 1026 999">Setting</th> <th data-bbox="1026 965 1481 999">Contents</th> </tr> </thead> <tbody> <tr> <td data-bbox="754 1010 1026 1084">04:PA035C-2.5MH_Manu</td> <td data-bbox="1026 1010 1481 1084">PA035, Asynchronous, 2.5Mbps, Half Duplex (Manual Setting)</td> </tr> <tr> <td data-bbox="754 1090 1026 1153">05:PA035C-4MH_Manu</td> <td data-bbox="1026 1090 1481 1153">PA035, Asynchronous, 4Mbps, Half Duplex (Manual Setting)</td> </tr> <tr> <td data-bbox="754 1160 1026 1223">06:RA062C-2.5MH_Manu</td> <td data-bbox="1026 1160 1481 1223">RA062, Asynchronous, 2.5Mbps, Half Duplex (Manual Setting)</td> </tr> <tr> <td data-bbox="754 1229 1026 1292">07:RA062C-4MH_Manu</td> <td data-bbox="1026 1229 1481 1292">RA062, Asynchronous, 4Mbps, Half Duplex (Manual Setting)</td> </tr> <tr> <td data-bbox="754 1299 1026 1332">80:RA062M-1MF</td> <td data-bbox="1026 1299 1481 1332">RA062, Manchester, 1Mbps, Full Duplex</td> </tr> <tr> <td data-bbox="754 1339 1026 1373">81:RA062M-2MF</td> <td data-bbox="1026 1339 1481 1373">RA062, Manchester, 2Mbps, Full Duplex</td> </tr> <tr> <td data-bbox="754 1379 1026 1442">84:ABS-E</td> <td data-bbox="1026 1379 1481 1442">ABS-E, 1Mbps (Absolute Encoder with Incremental Signal)</td> </tr> </tbody> </table> </td> </tr> <tr> <td data-bbox="252 1467 738 1872"> <p data-bbox="252 1467 738 1500">Absolute encoder, resolution setting</p> <p data-bbox="252 1507 738 1599">Sets the absolute encoder resolution. Sets the pulse number of motor shaft one rotation.</p> </td> <td colspan="2" data-bbox="738 1467 1489 1872"> <p data-bbox="738 1467 1489 1529">This is set when the motor encoder type is “absolute encoder”.</p> <table border="1" data-bbox="754 1529 1481 1861"> <thead> <tr> <th data-bbox="754 1529 930 1563">Setting</th> <th data-bbox="930 1529 1106 1563">Contents</th> <th data-bbox="1106 1529 1281 1563">Setting</th> <th data-bbox="1281 1529 1481 1563">Contents</th> </tr> </thead> <tbody> <tr> <td data-bbox="754 1574 930 1608">00:_2048 division</td> <td data-bbox="930 1574 1106 1608">2048 division</td> <td data-bbox="1106 1574 1281 1608">06:_131072 division</td> <td data-bbox="1281 1574 1481 1608">131072 division</td> </tr> <tr> <td data-bbox="754 1615 930 1648">01:_4096 division</td> <td data-bbox="930 1615 1106 1648">4096 division</td> <td data-bbox="1106 1615 1281 1648">07:_262144 division</td> <td data-bbox="1281 1615 1481 1648">262144 division</td> </tr> <tr> <td data-bbox="754 1655 930 1688">02:_8192 division</td> <td data-bbox="930 1655 1106 1688">8192 division</td> <td data-bbox="1106 1655 1281 1688">08:_524288 division</td> <td data-bbox="1281 1655 1481 1688">524288 division</td> </tr> <tr> <td data-bbox="754 1695 930 1758">03:_16384 division</td> <td data-bbox="930 1695 1106 1758">16384 division</td> <td data-bbox="1106 1695 1281 1758">09:_1048576 division</td> <td data-bbox="1281 1695 1481 1758">1048576 division</td> </tr> <tr> <td data-bbox="754 1765 930 1827">04:_32768 division</td> <td data-bbox="930 1765 1106 1827">32768 division</td> <td data-bbox="1106 1765 1281 1827">0A:_2097152 division</td> <td data-bbox="1281 1765 1481 1827">2097152 division</td> </tr> <tr> <td data-bbox="754 1834 930 1868">05:_65536 division</td> <td data-bbox="930 1834 1106 1868">65536 division</td> <td></td> <td></td> </tr> </tbody> </table> </td> </tr> <tr> <td data-bbox="252 1877 738 2000"> <p data-bbox="252 1877 738 1910">External encoder resolution</p> <p data-bbox="252 1917 738 1980">Sets the resolution of external encoder in use.</p> </td> <td colspan="2" data-bbox="738 1877 1489 2000"> <p data-bbox="738 1877 1489 1939">This is set when the system is full closed control or something.</p> <p data-bbox="738 1946 1489 2009">Sets the pulse number converted to motor shaft one rotation. 500P/R to 65535P/R Setting unit=Pulse/Rev.</p> </td> </tr> </tbody> </table>	Item			<p data-bbox="252 432 738 465">Motor encoder type</p> <p data-bbox="252 472 738 506">Selects the servo motor encoder type.</p>	<table border="1" data-bbox="754 461 1481 577"> <thead> <tr> <th data-bbox="754 461 1010 495">Setting value</th> <th data-bbox="1010 461 1481 495">Contents</th> </tr> </thead> <tbody> <tr> <td data-bbox="754 506 1010 539">00:_Incremental_ENC</td> <td data-bbox="1010 506 1481 539">Incremental Encoder</td> </tr> <tr> <td data-bbox="754 546 1010 580">01:_Absolute_ENC</td> <td data-bbox="1010 546 1481 580">Absolute Encoder</td> </tr> </tbody> </table>		Setting value	Contents	00:_Incremental_ENC	Incremental Encoder	01:_Absolute_ENC	Absolute Encoder	<p data-bbox="252 604 738 638">Incremental encoder, function setting</p> <p data-bbox="252 645 738 707">Selects detailed function of incremental encoder.</p>	<p data-bbox="738 604 1489 667">This is set when motor encoder type is “incremental encoder”.</p> <table border="1" data-bbox="754 667 1481 824"> <thead> <tr> <th data-bbox="754 667 1010 701">Setting value</th> <th data-bbox="1010 667 1481 701">Contents</th> </tr> </thead> <tbody> <tr> <td data-bbox="754 712 1010 775">00:_Standard</td> <td data-bbox="1010 712 1481 775">Wiring-Save Incremental Encoder [Standard (4-Pairs)]</td> </tr> <tr> <td data-bbox="754 781 1010 815">01:_7pairs_INC-E</td> <td data-bbox="1010 781 1481 815">Incremental Encoder with CS Signal. [7-Pairs]</td> </tr> </tbody> </table>		Setting value	Contents	00:_Standard	Wiring-Save Incremental Encoder [Standard (4-Pairs)]	01:_7pairs_INC-E	Incremental Encoder with CS Signal. [7-Pairs]	<p data-bbox="252 835 738 869">Incremental encoder, resolution setting</p> <p data-bbox="252 875 738 909">Sets the incremental encoder resolution.</p>	<p data-bbox="738 835 1489 898">Sets the pulse number of motor shaft one rotation. 500P/R to 65535P/R Setting unit=Pulse/Rev.</p>		<p data-bbox="252 902 738 936">Absolute encoder, function setting</p> <p data-bbox="252 943 738 1005">Selects detailed function of absolute encoder.</p>	<p data-bbox="738 902 1489 965">This is set when the motor encoder type is “absolute encoder”.</p> <table border="1" data-bbox="754 965 1481 1451"> <thead> <tr> <th data-bbox="754 965 1026 999">Setting</th> <th data-bbox="1026 965 1481 999">Contents</th> </tr> </thead> <tbody> <tr> <td data-bbox="754 1010 1026 1084">04:PA035C-2.5MH_Manu</td> <td data-bbox="1026 1010 1481 1084">PA035, Asynchronous, 2.5Mbps, Half Duplex (Manual Setting)</td> </tr> <tr> <td data-bbox="754 1090 1026 1153">05:PA035C-4MH_Manu</td> <td data-bbox="1026 1090 1481 1153">PA035, Asynchronous, 4Mbps, Half Duplex (Manual Setting)</td> </tr> <tr> <td data-bbox="754 1160 1026 1223">06:RA062C-2.5MH_Manu</td> <td data-bbox="1026 1160 1481 1223">RA062, Asynchronous, 2.5Mbps, Half Duplex (Manual Setting)</td> </tr> <tr> <td data-bbox="754 1229 1026 1292">07:RA062C-4MH_Manu</td> <td data-bbox="1026 1229 1481 1292">RA062, Asynchronous, 4Mbps, Half Duplex (Manual Setting)</td> </tr> <tr> <td data-bbox="754 1299 1026 1332">80:RA062M-1MF</td> <td data-bbox="1026 1299 1481 1332">RA062, Manchester, 1Mbps, Full Duplex</td> </tr> <tr> <td data-bbox="754 1339 1026 1373">81:RA062M-2MF</td> <td data-bbox="1026 1339 1481 1373">RA062, Manchester, 2Mbps, Full Duplex</td> </tr> <tr> <td data-bbox="754 1379 1026 1442">84:ABS-E</td> <td data-bbox="1026 1379 1481 1442">ABS-E, 1Mbps (Absolute Encoder with Incremental Signal)</td> </tr> </tbody> </table>		Setting	Contents	04:PA035C-2.5MH_Manu	PA035, Asynchronous, 2.5Mbps, Half Duplex (Manual Setting)	05:PA035C-4MH_Manu	PA035, Asynchronous, 4Mbps, Half Duplex (Manual Setting)	06:RA062C-2.5MH_Manu	RA062, Asynchronous, 2.5Mbps, Half Duplex (Manual Setting)	07:RA062C-4MH_Manu	RA062, Asynchronous, 4Mbps, Half Duplex (Manual Setting)	80:RA062M-1MF	RA062, Manchester, 1Mbps, Full Duplex	81:RA062M-2MF	RA062, Manchester, 2Mbps, Full Duplex	84:ABS-E	ABS-E, 1Mbps (Absolute Encoder with Incremental Signal)	<p data-bbox="252 1467 738 1500">Absolute encoder, resolution setting</p> <p data-bbox="252 1507 738 1599">Sets the absolute encoder resolution. Sets the pulse number of motor shaft one rotation.</p>	<p data-bbox="738 1467 1489 1529">This is set when the motor encoder type is “absolute encoder”.</p> <table border="1" data-bbox="754 1529 1481 1861"> <thead> <tr> <th data-bbox="754 1529 930 1563">Setting</th> <th data-bbox="930 1529 1106 1563">Contents</th> <th data-bbox="1106 1529 1281 1563">Setting</th> <th data-bbox="1281 1529 1481 1563">Contents</th> </tr> </thead> <tbody> <tr> <td data-bbox="754 1574 930 1608">00:_2048 division</td> <td data-bbox="930 1574 1106 1608">2048 division</td> <td data-bbox="1106 1574 1281 1608">06:_131072 division</td> <td data-bbox="1281 1574 1481 1608">131072 division</td> </tr> <tr> <td data-bbox="754 1615 930 1648">01:_4096 division</td> <td data-bbox="930 1615 1106 1648">4096 division</td> <td data-bbox="1106 1615 1281 1648">07:_262144 division</td> <td data-bbox="1281 1615 1481 1648">262144 division</td> </tr> <tr> <td data-bbox="754 1655 930 1688">02:_8192 division</td> <td data-bbox="930 1655 1106 1688">8192 division</td> <td data-bbox="1106 1655 1281 1688">08:_524288 division</td> <td data-bbox="1281 1655 1481 1688">524288 division</td> </tr> <tr> <td data-bbox="754 1695 930 1758">03:_16384 division</td> <td data-bbox="930 1695 1106 1758">16384 division</td> <td data-bbox="1106 1695 1281 1758">09:_1048576 division</td> <td data-bbox="1281 1695 1481 1758">1048576 division</td> </tr> <tr> <td data-bbox="754 1765 930 1827">04:_32768 division</td> <td data-bbox="930 1765 1106 1827">32768 division</td> <td data-bbox="1106 1765 1281 1827">0A:_2097152 division</td> <td data-bbox="1281 1765 1481 1827">2097152 division</td> </tr> <tr> <td data-bbox="754 1834 930 1868">05:_65536 division</td> <td data-bbox="930 1834 1106 1868">65536 division</td> <td></td> <td></td> </tr> </tbody> </table>		Setting	Contents	Setting	Contents	00:_2048 division	2048 division	06:_131072 division	131072 division	01:_4096 division	4096 division	07:_262144 division	262144 division	02:_8192 division	8192 division	08:_524288 division	524288 division	03:_16384 division	16384 division	09:_1048576 division	1048576 division	04:_32768 division	32768 division	0A:_2097152 division	2097152 division	05:_65536 division	65536 division			<p data-bbox="252 1877 738 1910">External encoder resolution</p> <p data-bbox="252 1917 738 1980">Sets the resolution of external encoder in use.</p>	<p data-bbox="738 1877 1489 1939">This is set when the system is full closed control or something.</p> <p data-bbox="738 1946 1489 2009">Sets the pulse number converted to motor shaft one rotation. 500P/R to 65535P/R Setting unit=Pulse/Rev.</p>	
Item																																																																														
<p data-bbox="252 432 738 465">Motor encoder type</p> <p data-bbox="252 472 738 506">Selects the servo motor encoder type.</p>	<table border="1" data-bbox="754 461 1481 577"> <thead> <tr> <th data-bbox="754 461 1010 495">Setting value</th> <th data-bbox="1010 461 1481 495">Contents</th> </tr> </thead> <tbody> <tr> <td data-bbox="754 506 1010 539">00:_Incremental_ENC</td> <td data-bbox="1010 506 1481 539">Incremental Encoder</td> </tr> <tr> <td data-bbox="754 546 1010 580">01:_Absolute_ENC</td> <td data-bbox="1010 546 1481 580">Absolute Encoder</td> </tr> </tbody> </table>		Setting value	Contents	00:_Incremental_ENC	Incremental Encoder	01:_Absolute_ENC	Absolute Encoder																																																																						
Setting value	Contents																																																																													
00:_Incremental_ENC	Incremental Encoder																																																																													
01:_Absolute_ENC	Absolute Encoder																																																																													
<p data-bbox="252 604 738 638">Incremental encoder, function setting</p> <p data-bbox="252 645 738 707">Selects detailed function of incremental encoder.</p>	<p data-bbox="738 604 1489 667">This is set when motor encoder type is “incremental encoder”.</p> <table border="1" data-bbox="754 667 1481 824"> <thead> <tr> <th data-bbox="754 667 1010 701">Setting value</th> <th data-bbox="1010 667 1481 701">Contents</th> </tr> </thead> <tbody> <tr> <td data-bbox="754 712 1010 775">00:_Standard</td> <td data-bbox="1010 712 1481 775">Wiring-Save Incremental Encoder [Standard (4-Pairs)]</td> </tr> <tr> <td data-bbox="754 781 1010 815">01:_7pairs_INC-E</td> <td data-bbox="1010 781 1481 815">Incremental Encoder with CS Signal. [7-Pairs]</td> </tr> </tbody> </table>		Setting value	Contents	00:_Standard	Wiring-Save Incremental Encoder [Standard (4-Pairs)]	01:_7pairs_INC-E	Incremental Encoder with CS Signal. [7-Pairs]																																																																						
Setting value	Contents																																																																													
00:_Standard	Wiring-Save Incremental Encoder [Standard (4-Pairs)]																																																																													
01:_7pairs_INC-E	Incremental Encoder with CS Signal. [7-Pairs]																																																																													
<p data-bbox="252 835 738 869">Incremental encoder, resolution setting</p> <p data-bbox="252 875 738 909">Sets the incremental encoder resolution.</p>	<p data-bbox="738 835 1489 898">Sets the pulse number of motor shaft one rotation. 500P/R to 65535P/R Setting unit=Pulse/Rev.</p>																																																																													
<p data-bbox="252 902 738 936">Absolute encoder, function setting</p> <p data-bbox="252 943 738 1005">Selects detailed function of absolute encoder.</p>	<p data-bbox="738 902 1489 965">This is set when the motor encoder type is “absolute encoder”.</p> <table border="1" data-bbox="754 965 1481 1451"> <thead> <tr> <th data-bbox="754 965 1026 999">Setting</th> <th data-bbox="1026 965 1481 999">Contents</th> </tr> </thead> <tbody> <tr> <td data-bbox="754 1010 1026 1084">04:PA035C-2.5MH_Manu</td> <td data-bbox="1026 1010 1481 1084">PA035, Asynchronous, 2.5Mbps, Half Duplex (Manual Setting)</td> </tr> <tr> <td data-bbox="754 1090 1026 1153">05:PA035C-4MH_Manu</td> <td data-bbox="1026 1090 1481 1153">PA035, Asynchronous, 4Mbps, Half Duplex (Manual Setting)</td> </tr> <tr> <td data-bbox="754 1160 1026 1223">06:RA062C-2.5MH_Manu</td> <td data-bbox="1026 1160 1481 1223">RA062, Asynchronous, 2.5Mbps, Half Duplex (Manual Setting)</td> </tr> <tr> <td data-bbox="754 1229 1026 1292">07:RA062C-4MH_Manu</td> <td data-bbox="1026 1229 1481 1292">RA062, Asynchronous, 4Mbps, Half Duplex (Manual Setting)</td> </tr> <tr> <td data-bbox="754 1299 1026 1332">80:RA062M-1MF</td> <td data-bbox="1026 1299 1481 1332">RA062, Manchester, 1Mbps, Full Duplex</td> </tr> <tr> <td data-bbox="754 1339 1026 1373">81:RA062M-2MF</td> <td data-bbox="1026 1339 1481 1373">RA062, Manchester, 2Mbps, Full Duplex</td> </tr> <tr> <td data-bbox="754 1379 1026 1442">84:ABS-E</td> <td data-bbox="1026 1379 1481 1442">ABS-E, 1Mbps (Absolute Encoder with Incremental Signal)</td> </tr> </tbody> </table>		Setting	Contents	04:PA035C-2.5MH_Manu	PA035, Asynchronous, 2.5Mbps, Half Duplex (Manual Setting)	05:PA035C-4MH_Manu	PA035, Asynchronous, 4Mbps, Half Duplex (Manual Setting)	06:RA062C-2.5MH_Manu	RA062, Asynchronous, 2.5Mbps, Half Duplex (Manual Setting)	07:RA062C-4MH_Manu	RA062, Asynchronous, 4Mbps, Half Duplex (Manual Setting)	80:RA062M-1MF	RA062, Manchester, 1Mbps, Full Duplex	81:RA062M-2MF	RA062, Manchester, 2Mbps, Full Duplex	84:ABS-E	ABS-E, 1Mbps (Absolute Encoder with Incremental Signal)																																																												
Setting	Contents																																																																													
04:PA035C-2.5MH_Manu	PA035, Asynchronous, 2.5Mbps, Half Duplex (Manual Setting)																																																																													
05:PA035C-4MH_Manu	PA035, Asynchronous, 4Mbps, Half Duplex (Manual Setting)																																																																													
06:RA062C-2.5MH_Manu	RA062, Asynchronous, 2.5Mbps, Half Duplex (Manual Setting)																																																																													
07:RA062C-4MH_Manu	RA062, Asynchronous, 4Mbps, Half Duplex (Manual Setting)																																																																													
80:RA062M-1MF	RA062, Manchester, 1Mbps, Full Duplex																																																																													
81:RA062M-2MF	RA062, Manchester, 2Mbps, Full Duplex																																																																													
84:ABS-E	ABS-E, 1Mbps (Absolute Encoder with Incremental Signal)																																																																													
<p data-bbox="252 1467 738 1500">Absolute encoder, resolution setting</p> <p data-bbox="252 1507 738 1599">Sets the absolute encoder resolution. Sets the pulse number of motor shaft one rotation.</p>	<p data-bbox="738 1467 1489 1529">This is set when the motor encoder type is “absolute encoder”.</p> <table border="1" data-bbox="754 1529 1481 1861"> <thead> <tr> <th data-bbox="754 1529 930 1563">Setting</th> <th data-bbox="930 1529 1106 1563">Contents</th> <th data-bbox="1106 1529 1281 1563">Setting</th> <th data-bbox="1281 1529 1481 1563">Contents</th> </tr> </thead> <tbody> <tr> <td data-bbox="754 1574 930 1608">00:_2048 division</td> <td data-bbox="930 1574 1106 1608">2048 division</td> <td data-bbox="1106 1574 1281 1608">06:_131072 division</td> <td data-bbox="1281 1574 1481 1608">131072 division</td> </tr> <tr> <td data-bbox="754 1615 930 1648">01:_4096 division</td> <td data-bbox="930 1615 1106 1648">4096 division</td> <td data-bbox="1106 1615 1281 1648">07:_262144 division</td> <td data-bbox="1281 1615 1481 1648">262144 division</td> </tr> <tr> <td data-bbox="754 1655 930 1688">02:_8192 division</td> <td data-bbox="930 1655 1106 1688">8192 division</td> <td data-bbox="1106 1655 1281 1688">08:_524288 division</td> <td data-bbox="1281 1655 1481 1688">524288 division</td> </tr> <tr> <td data-bbox="754 1695 930 1758">03:_16384 division</td> <td data-bbox="930 1695 1106 1758">16384 division</td> <td data-bbox="1106 1695 1281 1758">09:_1048576 division</td> <td data-bbox="1281 1695 1481 1758">1048576 division</td> </tr> <tr> <td data-bbox="754 1765 930 1827">04:_32768 division</td> <td data-bbox="930 1765 1106 1827">32768 division</td> <td data-bbox="1106 1765 1281 1827">0A:_2097152 division</td> <td data-bbox="1281 1765 1481 1827">2097152 division</td> </tr> <tr> <td data-bbox="754 1834 930 1868">05:_65536 division</td> <td data-bbox="930 1834 1106 1868">65536 division</td> <td></td> <td></td> </tr> </tbody> </table>		Setting	Contents	Setting	Contents	00:_2048 division	2048 division	06:_131072 division	131072 division	01:_4096 division	4096 division	07:_262144 division	262144 division	02:_8192 division	8192 division	08:_524288 division	524288 division	03:_16384 division	16384 division	09:_1048576 division	1048576 division	04:_32768 division	32768 division	0A:_2097152 division	2097152 division	05:_65536 division	65536 division																																																		
Setting	Contents	Setting	Contents																																																																											
00:_2048 division	2048 division	06:_131072 division	131072 division																																																																											
01:_4096 division	4096 division	07:_262144 division	262144 division																																																																											
02:_8192 division	8192 division	08:_524288 division	524288 division																																																																											
03:_16384 division	16384 division	09:_1048576 division	1048576 division																																																																											
04:_32768 division	32768 division	0A:_2097152 division	2097152 division																																																																											
05:_65536 division	65536 division																																																																													
<p data-bbox="252 1877 738 1910">External encoder resolution</p> <p data-bbox="252 1917 738 1980">Sets the resolution of external encoder in use.</p>	<p data-bbox="738 1877 1489 1939">This is set when the system is full closed control or something.</p> <p data-bbox="738 1946 1489 2009">Sets the pulse number converted to motor shaft one rotation. 500P/R to 65535P/R Setting unit=Pulse/Rev.</p>																																																																													

6.Operations

[Confirmation & Change of servo motor model number]

Procedure	Item and Contents	
6	<u>Confirming the combined servo motor</u> <u>System parameter setting</u> Use the AC servo system supporting tool R-Setup to confirm and set the model type of combined servo motor. For how to use [the setup software R-Setup], refer to [R-SETUP Instruction Manual].	
	Item	e.g.: <u>Q2AA07030D</u> (0000-0064) ↑ <u>Model number of combined motor is displayed.</u> Combined motor can be changed at <u>Motor parameter setting.</u>

Procedure	Item and Contents	
7	<u>Re-turning on the power again</u> <u>Power shut off→turn ON again</u> Turn OFF the power of servo amplifier and turn it ON again. Turning OFF the power makes the parameter re-written. Without turning OFF the power, the parameter cannot be changed. Make sure to turn OFF→turn ON again.	

Procedure	Item and Contents	
8	<u>Reconfirming the specifications</u> <u>Reconfirmation</u> Reconfirm the specifications and combination of the changed servo amplifier, servo motor encoder and servo motor. <u>Many of the troubles at test run, such as servo motor not operating, are caused by mistakes in parameter setting.</u>	

6.Operations

[JOG operation]

■ [Procedure 9] JOG Operation

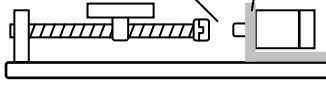
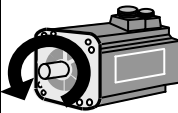
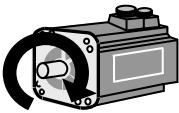
Procedure	Item	Contents			
9	<u>JOG operation</u> Do not connect the servo motor shaft to the machine to keep the status of no load for JOG operation. Confirm that the servo motor rotates forward and backward.	<div style="display: flex; justify-content: space-around; align-items: center;"> <div style="border: 1px solid black; padding: 5px; font-size: small;">Do not connect servo motor shaft to the machine.</div> <div style="text-align: center;">  </div> <div style="border: 1px solid black; padding: 5px; font-size: small;">Servo motor flange is fixed.</div> </div> 			
	How to use digital operator				
	Setting of [forward over travel] is to be changed. Standard setting at the time of shipment 0d → 00 Can also be changed from general parameter group 9 page 00.	MODE	Press the MODE key to display basic mode.	bA 00	
		▲▼▶	Press the cursor/up/down key to display bA 07.	bA 07	
		WR/▶	Press the WR/□ key for more than 1 sec, and the set value is displayed.	bA 0d	
		▲▼▶	Press the cursor/up/down key to change 0d to 00. [Forward rotation over travel disabled.]	bA 00	
		WR/▶	Press the WR/□ key for more than 1 sec, and the values is written.	bA 00	
	Setting of [reverse over travel] is to be changed. Standard setting at the time of shipment 0b → 00 Can also be changed from general parameter group 9 page01.	▲▼▶	Press the cursor/up/down key to display bA 08.	bA 08	
		WR/▶	Press the “WR/▶” key for more than 1 sec, and the set value is displayed.	bA 0b	
		▲▼▶	Press the cursor/up/down key to change 0bto 00. [Reverse over travel disabled]	bA 00	
		WR/▶	Press the “WR/▶” key for more than 1 sec, and the set value is written.	bA 00	
		MODE	Press the MODE key to terminate.		
	Forward (CCW)	Reverse (CW)	Input key	Description	Display
	 Motor forward rotation	 Motor reverse rotation	MODE	Press the MODE key to display test run/adjustment mode.	Ad 00
			▲	Press the “▲” key to display “Ad 00” of speed JOG.	Ad 00
			WR/▶	Press the “WR/▶” key for more than 1 sec, and confirmation display “-y_n-” will appear.	-y_n-
			▲	Press the “▲” key to display “rdy”. Press the “▼” key to return to “Ad 00”.	rdy
			WR/▶	Press the “WR/▶” key for more than 1 sec, and servo ON status.	8
			▲	Press the “▲” key, and the servo motor rotates forward (CCW) at 50min ⁻¹ .	r.u.n. .8.
			▼	Press the “▼” key, and the servo motor rotates backward (CW)at 50min ⁻¹ .	r.u.n. .8.
MODE			Press the MODE key to terminate. Alarm “AL dF” is displayed.	AL dF	
Though alarm “AL dF” is displayed, but this is not an error.					

 The velocity at JOG operation can be changed at general parameter group B page 00.

* Velocity JOG can not be executed when “no. rdy” is displayed. Refer to [4. Digital Operator “test run mode operations and display”].

6.Operations

■ [Procedure 10 to 14]

Connection of upper device with CN1, parameter setting for I/O signals

Procedure	Item	Contents																											
10	I/O signal setting	Settings for generic I/O signals (CN1) are standard ones set at the time of shipment. Necessary I/O signals are set at the servo amplifier.																											
	General input signal Standard setting at the time of shipment	<p>General parameter Group 9</p> <table border="1"> <thead> <tr> <th>Input signal</th> <th>Name</th> <th>Set value</th> </tr> </thead> <tbody> <tr> <td>CONT1</td> <td>SERVO-ON Function</td> <td>02: _CONT1_ON</td> </tr> <tr> <td>CONT2</td> <td>Velocity Loop Proportional Control, Switching Function</td> <td>04: _CONT2_ON</td> </tr> <tr> <td>CONT3</td> <td>Absolute Encoder Clear Function</td> <td>06: _CONT3_ON</td> </tr> <tr> <td>CONT4</td> <td>Deviation Clear Function</td> <td>08: _CONT4_ON</td> </tr> <tr> <td>CONT5</td> <td>Negative Over-Travel Function</td> <td>0B: _CONT5_OFF</td> </tr> <tr> <td>CONT6</td> <td>Positive Over-Travel Function</td> <td>0D: _CONT6_OFF</td> </tr> <tr> <td>CONT7</td> <td>Torque Limit, Input Selection</td> <td>0E: _CONT7_ON</td> </tr> <tr> <td>CONT8</td> <td>Alarm Reset Function</td> <td>10: _CONT8_ON</td> </tr> </tbody> </table> <p> General input signals (CONT1 TO CONT8) shall be allocated to functions necessary to the device, referring to [Chapter 5, Parameter][Parameter setting value Group9].</p>	Input signal	Name	Set value	CONT1	SERVO-ON Function	02: _CONT1_ON	CONT2	Velocity Loop Proportional Control, Switching Function	04: _CONT2_ON	CONT3	Absolute Encoder Clear Function	06: _CONT3_ON	CONT4	Deviation Clear Function	08: _CONT4_ON	CONT5	Negative Over-Travel Function	0B: _CONT5_OFF	CONT6	Positive Over-Travel Function	0D: _CONT6_OFF	CONT7	Torque Limit, Input Selection	0E: _CONT7_ON	CONT8	Alarm Reset Function	10: _CONT8_ON
	Input signal	Name	Set value																										
CONT1	SERVO-ON Function	02: _CONT1_ON																											
CONT2	Velocity Loop Proportional Control, Switching Function	04: _CONT2_ON																											
CONT3	Absolute Encoder Clear Function	06: _CONT3_ON																											
CONT4	Deviation Clear Function	08: _CONT4_ON																											
CONT5	Negative Over-Travel Function	0B: _CONT5_OFF																											
CONT6	Positive Over-Travel Function	0D: _CONT6_OFF																											
CONT7	Torque Limit, Input Selection	0E: _CONT7_ON																											
CONT8	Alarm Reset Function	10: _CONT8_ON																											
General output signal Standard setting at the time of shipment	<p>General parameter Group A</p> <table border="1"> <thead> <tr> <th>Page</th> <th>Name</th> <th>Standard set value</th> </tr> </thead> <tbody> <tr> <td>00</td> <td>General Purpose Output 1</td> <td>18: _INP_ON</td> </tr> <tr> <td>01</td> <td>General Purpose Output 2</td> <td>0C: _TLC_ON</td> </tr> <tr> <td>02</td> <td>General Purpose Output 3</td> <td>02: _S-RDY_ON</td> </tr> <tr> <td>03</td> <td>General Purpose Output 4</td> <td>0A: _MBR_ON</td> </tr> <tr> <td>04</td> <td>General Purpose Output 5</td> <td>33: _ALM5_OFF</td> </tr> <tr> <td>05</td> <td>General Purpose Output 6</td> <td>35: _ALM6_OFF</td> </tr> <tr> <td>06</td> <td>General Purpose Output 7</td> <td>37: _ALM7_OFF</td> </tr> <tr> <td>07</td> <td>General Purpose Output 8</td> <td>39: _ALM_OFF</td> </tr> </tbody> </table> <p> Generic output signals (OUT1 TO OUT8) shall be allocated to functions necessary to the device, referring to [Chapter 5, Parameter][Parameter setting value Group A].</p>	Page	Name	Standard set value	00	General Purpose Output 1	18: _INP_ON	01	General Purpose Output 2	0C: _TLC_ON	02	General Purpose Output 3	02: _S-RDY_ON	03	General Purpose Output 4	0A: _MBR_ON	04	General Purpose Output 5	33: _ALM5_OFF	05	General Purpose Output 6	35: _ALM6_OFF	06	General Purpose Output 7	37: _ALM7_OFF	07	General Purpose Output 8	39: _ALM_OFF	
Page	Name	Standard set value																											
00	General Purpose Output 1	18: _INP_ON																											
01	General Purpose Output 2	0C: _TLC_ON																											
02	General Purpose Output 3	02: _S-RDY_ON																											
03	General Purpose Output 4	0A: _MBR_ON																											
04	General Purpose Output 5	33: _ALM5_OFF																											
05	General Purpose Output 6	35: _ALM6_OFF																											
06	General Purpose Output 7	37: _ALM7_OFF																											
07	General Purpose Output 8	39: _ALM_OFF																											

Procedure	Item	Contents
11	Confirmation of input signals	<p>Input signal status is monitored by the monitoring function inside the servo amplifier. Confirm that there are protective functions such as emergency stop, over travel and alarm reset.</p> <p> Confirm that every I/O signal is properly functioning using generic input (CONT8 TO CONT1) monitor and generic output (OUT8 TO OUT1) monitor, referring to [Chapter 4, Digital operator][How to operate monitor mode].</p>

Procedure	Item	Contents
12	Servo ON signal is input.	<p>Servo ON signal is input and the servo motor is excited. Confirm that the digital operator on the servo amplifier front is drawing the character “8.”</p> <p> The display shown below indicates over travel status. When there is nothing wrong with the device, check again the above procedure 10 TO 11 and [Chapter 3, Wiring] [Generic input wiring example].</p> <p>Over travel { </p>

6.Operations

[Operation sequence]

Procedure	Item	Contents								
13	Command input	<p>Input the command suitable for the control mode in use. Check that the rotation direction matches the command input. Confirm the command input using monitoring function inside the servo amplifier.</p> <ul style="list-style-type: none"> ● When velocity controlled, torque controlled. <table border="1" style="margin-left: 20px;"> <tr> <td colspan="2">Monitor mode 0D</td> </tr> <tr> <td>Analog velocity command/ Analog torque command input voltage</td> <td>Command voltage being input is displayed.</td> </tr> </table> ● When position controlled. <table border="1" style="margin-left: 20px;"> <tr> <td colspan="2">Monitor mode 0E</td> </tr> <tr> <td>Position pulse monitor (Position command pulse input frequency)</td> <td>Command pulse frequency being input is displayed.</td> </tr> </table> <p> Many of the cases when monitor values do not change with command input are resulted from wrong wiring. Check the wiring again, referring to [Chapter3, Wiring] [Terminal layout] [Wiring example of input circuit].</p>	Monitor mode 0D		Analog velocity command/ Analog torque command input voltage	Command voltage being input is displayed.	Monitor mode 0E		Position pulse monitor (Position command pulse input frequency)	Command pulse frequency being input is displayed.
Monitor mode 0D										
Analog velocity command/ Analog torque command input voltage	Command voltage being input is displayed.									
Monitor mode 0E										
Position pulse monitor (Position command pulse input frequency)	Command pulse frequency being input is displayed.									

Procedure	Item	Contents
14	Power shut off	Turns OFF the servo ON signal, then turns OFF the power supply.

■ [Procedure 15] Connect the servo motor shaft with the machine and check the operation.

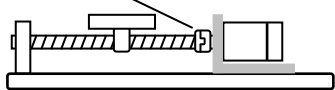
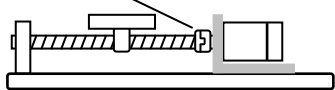
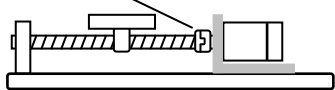
Procedure	Item	Contents		
15	Command input (Low-speed)	<table border="1" style="margin-left: 20px;"> <tr> <td>Connect the servo motor shaft with the machine</td> <td></td> </tr> </table> <p>Input the command (low speed) suitable for the control mode in use. Check the operation direction, distance, emergency stop and over travel (F-OT·R-OT) so that they are properly operating.</p>	Connect the servo motor shaft with the machine	
Connect the servo motor shaft with the machine				

■ [Procedure 16] Input the command of the operation pattern in use and start the machine.

Procedure	Item	Contents
16	Operation	At the time of shipment, auto-tuning (auto-adjustment for servo gain and filter, etc.) has been set. If there is nothing wrong with operation, manual tuning is not necessary.

6.Operations

[Operation sequence]

- Operation sequence from power turn ON to power shut OFF at the standard shipment setting

The frequency of the power ON/OFF of the servo amplifier should be less than 5 times/hour and less than 30 times/day. Please give 10 minutes or more to the interval of power ON/OFF.

- [Power ON → Servo ON]

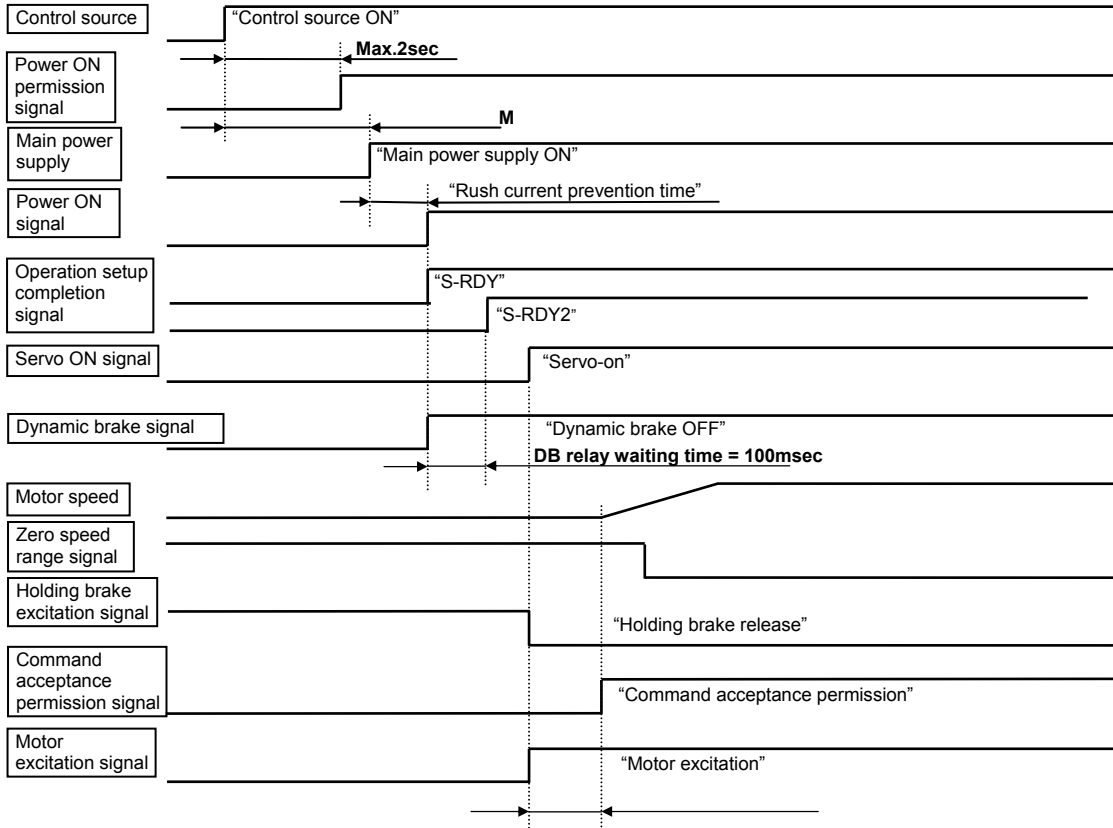

- [Servo OFF → Power OFF]

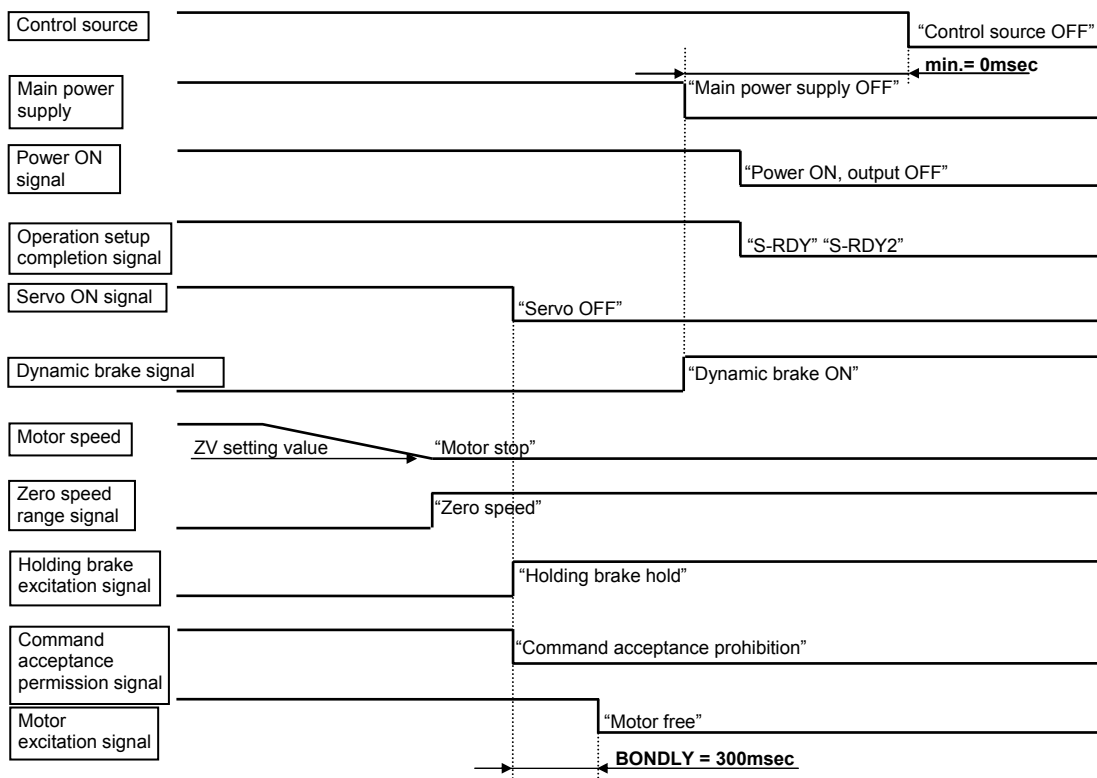

6.Operations

Alarm sequence

When an alarm occurs, the servo motor is stopped by dynamic brake or servo brake. Which brake is used depends on the alarm. Refer to [Chapter 8, Maintenance] [Alarm list].

Stop by dynamic brake at alarm

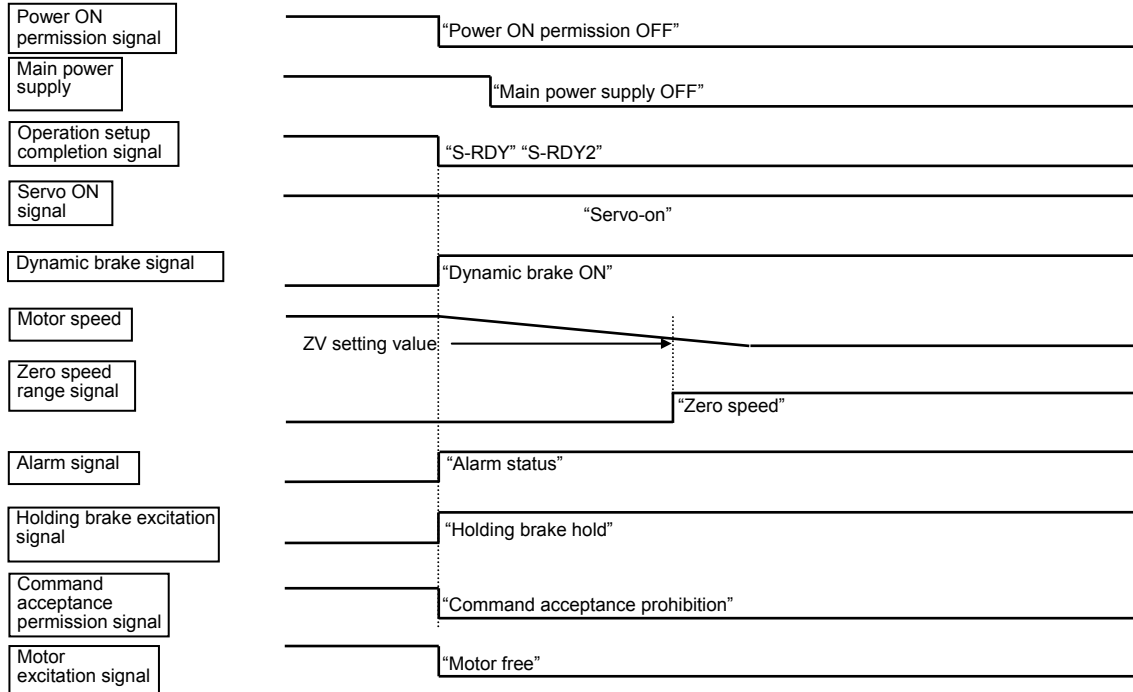

Stop by servo brake at alarm

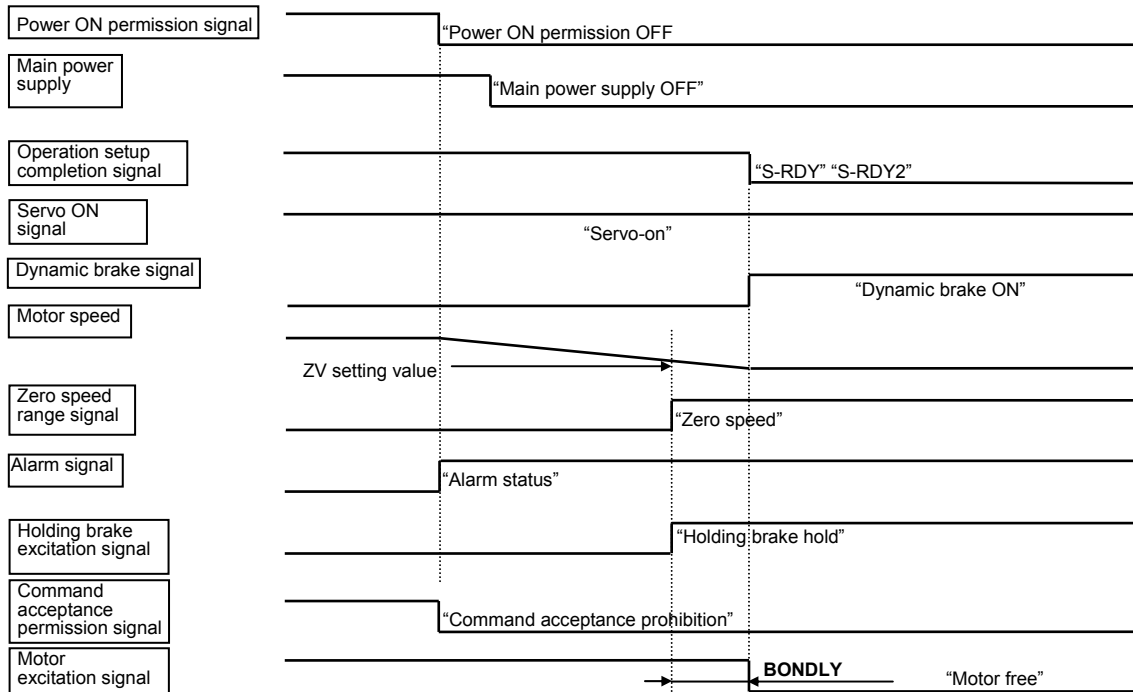

Install a protective circuit referring to [Chapter 3, Wiring] [Wiring example of high voltage circuit, protective circuit]. The above sequence is the one when protective circuit is installed.

6.Operations

■ Sequence at alarm reset

Alarms can be reset by inputting alarm reset signal from generic input signal.

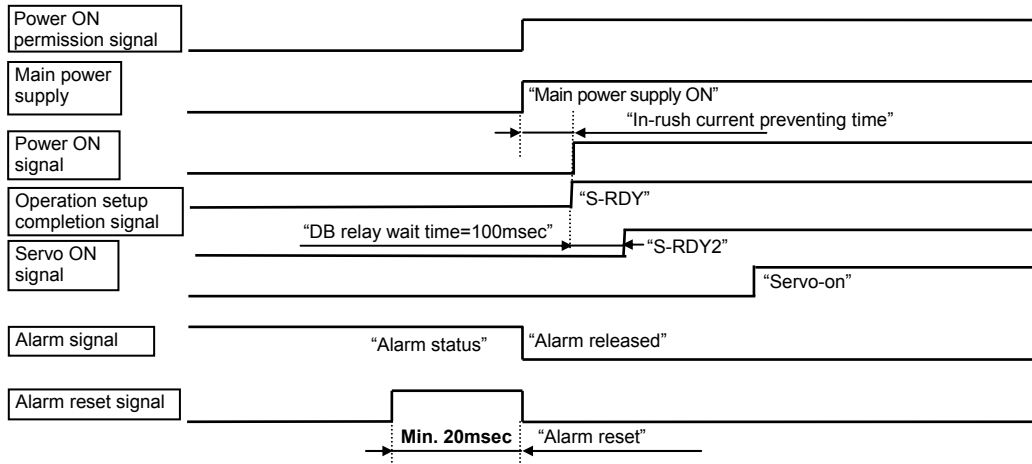

Some alarms cannot be reset unless the power is reset (control power is turned OFF and ON again) or encoder is cleared. Refer to [Chapter 8, Maintenance] [Alarm list].

■ Sequence when power is turned OFF during operation (During servo ON)

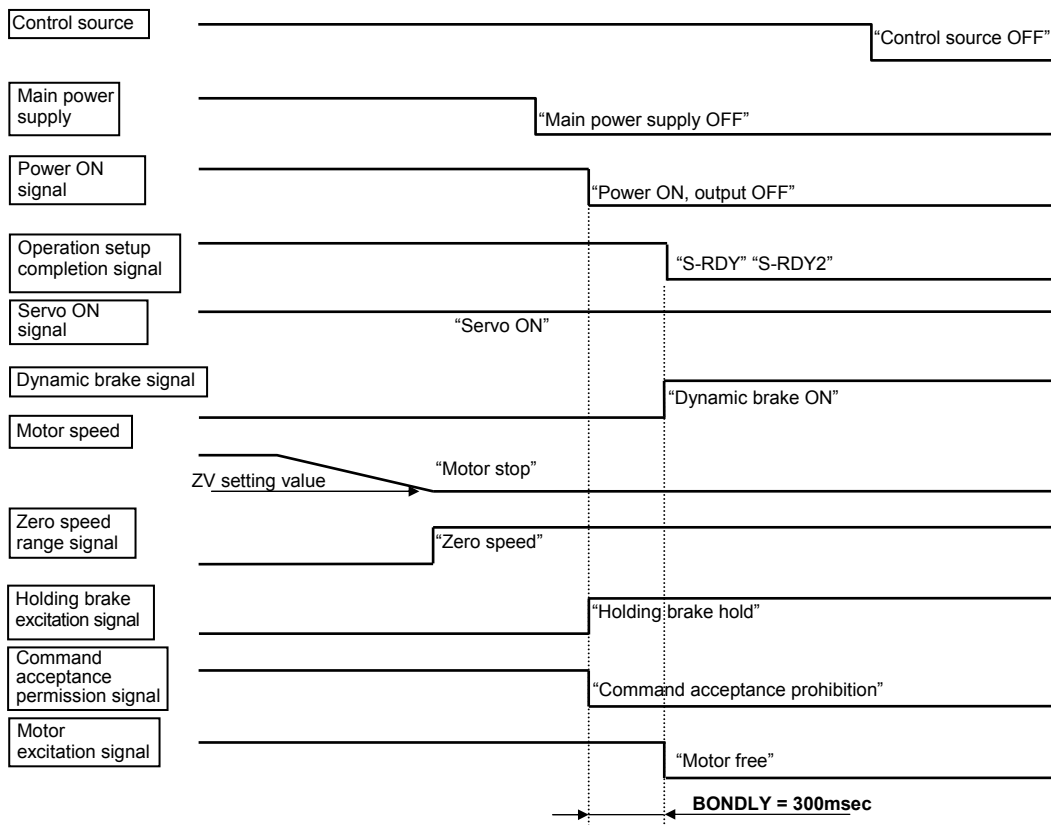

No Text on This Page.

[Adjustment · Functions]

◆	Servo gain tuning	7-1
◆	Functions of Group 8.....	7-7
◆	Functions of Group 9.....	7-25
◆	Functions of Group B	7-31
◆	Functions of Group C	7-36
◆	Description of monitor	7-39

7.Adjustment·Functions

[Servo gain tuning]

■ Structure of tuning <General parameter Group 0>

For “parameter Group 0,” tuning structure of the R series servo amplifier is as follows.

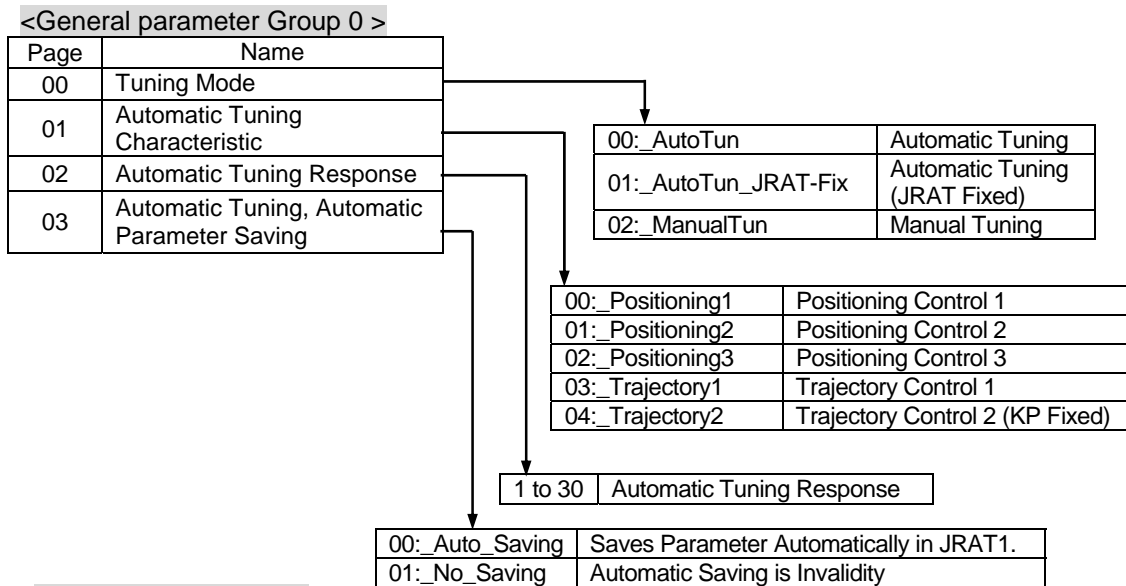

● Tuning Mode [page 00]

00: _AutoTun auto-tuning

The servo amplifier estimates the load inertia moment ratio of the machine and equipment at real time and automatically tunes the servo gain so that it will become the best one. The parameters for the servo amplifier to automatically tune vary depending on the selected auto-tuning characteristics.

- * The servo amplifier estimates the load inertia moment ratio at the time of acceleration/deceleration. Therefore, for operations with only excessively low acceleration/deceleration time constant or with only low torque with low velocity, this mode cannot be used. Also, operations with large disturbance torque or with large mechanical clearance, this mode cannot be used, either.

01: _AutoTun_JRAT-Fix Usage at Auto-tuning [JRAT manual setting].

01: _AutoTun_JRAT-Fix Automatic Tuning (JRAT Fixed)

Based on the load inertia moment ratio (JRAT1) which was set, the servo amplifier automatically tunes and makes the servo gain the best one. The parameters for the servo amplifier to automatically tune vary depending on the selected auto-tuning characteristics.

02: _ManualTun Manual Tuning

This is used in order for adjusting the servo gain to the machine and equipment to ensure the maximum response, and when characteristics in auto-tuning are insufficient.

● Automatic Tuning Characteristic [page 01]

Characteristics adjusted to machines and equipment are selected when Automatic Tuning and Automatic Tuning (JRAT Fixed) are used. When Manual Tuning is used, this does not function.

- * In trajectory control, since presumed inertia changes, position loop gain is changed by it and the final positioning characteristic is influenced. If you want to avoid this, use by manual tuning or local control (Kp manual setup).

● Automatic Tuning Response [page 02]

Set this when Automatic Tuning and Automatic Tuning (JRAT Fixed) are used. The larger set value makes the response higher. Set this suitable for the equipment rigidity. When Manual Tuning is used, this does not function.

● Automatic Tuning, Automatic Parameter Saving [load inertia moment ratio] [page 03]

The “load inertia moment ratio” obtained from auto-tuning is automatically saved in parameter JRAT1 at every 2 hours. The set value is enabled when Automatic Tuning is used.

When Automatic Tuning (JRAT Fixed) and Manual Tuning are used, this does not function.

7.Adjustment·Functions

[Servo gain tuning]

■ Tuning method selecting procedure

* The flow chart in the left shows selecting method of tuning mode and tuning characteristics. Settings for auto-tuning response are not indicated here. Auto-tuning response shall be tuned at each status.

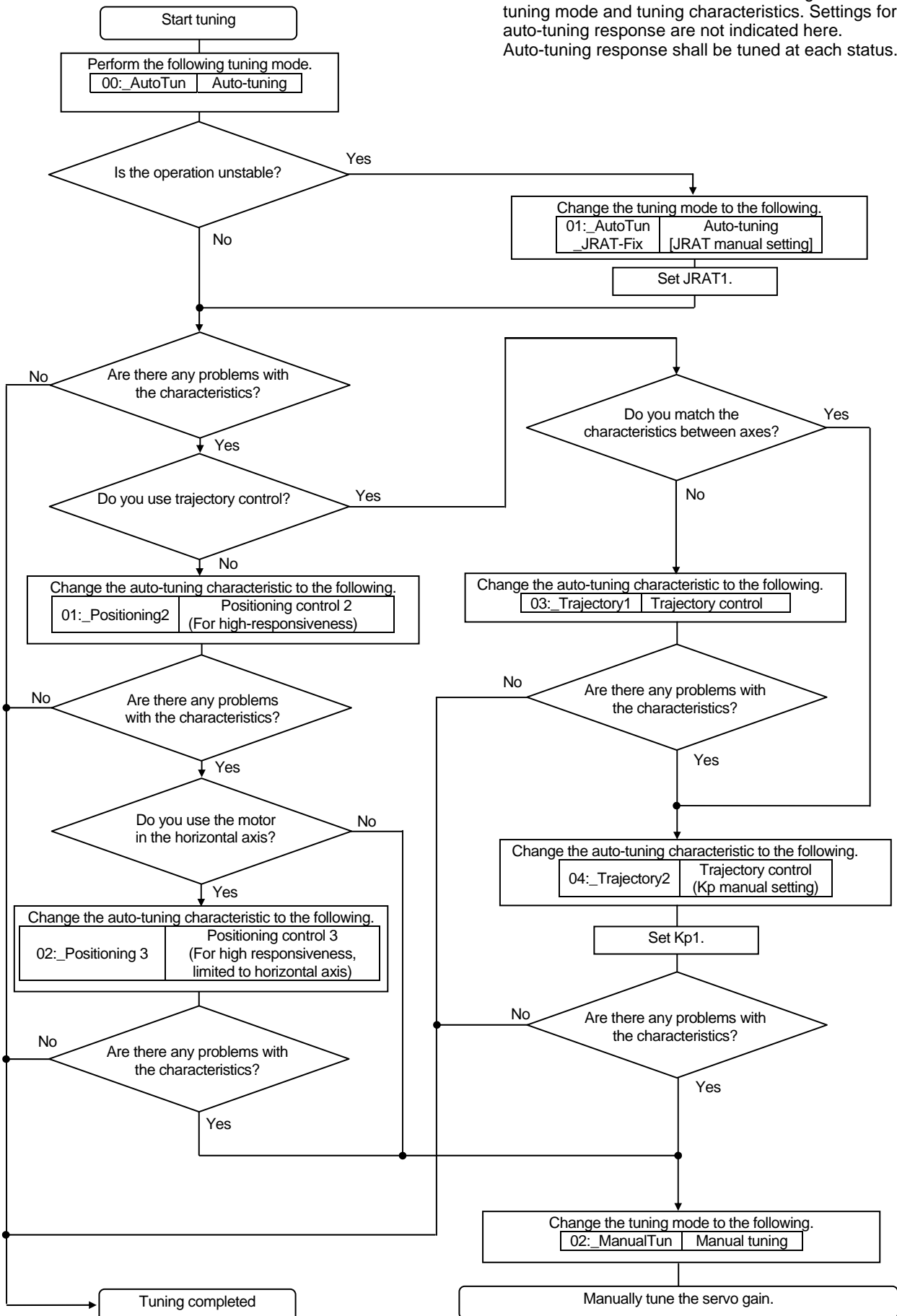

7.Adjustment·Functions

[Servo gain tuning]

■ Monitoring servo gain adjustment parameter

The following parameters can be monitored when auto-tuning is used.

● Digital operator

Monitor mode	Name
Page 15	Load Inertia Ratio Monitor
Page 16	Position Loop Proportional Gain Monitor
Page 18	Velocity Loop Proportional Gain Monitor
Page 19	Velocity Loop Integral Time Constant Monitor
Page 1A	Torque Command Filter Monitor

For how to operate these, refer to “Chapter 4, Digital operator.”

● R-SETUP

#1	Page	Symbol	Name	Present Value	Unit
0B	EV-APMON		External Actual Position Monitor (External Encoder)	0	Pulse
0C	CPMON		Command Position Monitor	0	Pulse
0D	VICTC-IN		Analog Velocity Command/Analog Torque Command Input	0	mV
0E	FMON		Position Command Pulse Input Frequency Monitor	0	1/Pulse/s
0F	CSU		U-Phase Electric Angle Monitor	240	deg
10	PS-H		Absolute Encoder PS Data (High)	0.0000000 H	√2/2 P
11	PS-L		Absolute Encoder PS Data (Low)	0.0000000 H	Pulse
12	RegP		Regenerative Resistor Operation Percentage	0.00	%
13	OPRT		Motor Operating Rate Monitor	64	%
14	PROPRT		Predicted Motor Operating Rate Monitor	0	%
15	JRAT_MON		Control Loop Parameter - Load Inertia (Mass) Ratio Monitor	368	%
16	KVP_MON		Control Loop Parameter - Position Loop Proportional Gain Monitor	30	1/s
17	TVI_MON		Control Loop Parameter - Position Loop Integral Time Constant	1000.0	ms
18	KVP_MON		Control Loop Parameter - Velocity Loop Proportional Gain Monitor	60	Hz
19	TVI_MON		Control Loop Parameter - Velocity Loop Integral Time Constant	35.0	ms
1A	TCFIL_MON		Control Loop Parameter - Torque (Force) Command Filter Monitor	150	Hz
1B	INCE_MON		Incremental Encoder Signal Monitor	0111_0100	
1C	TLMON_EST		Load Torque (Force) Monitor (Estimate Value)	0	%
1D	P_MON		Power Monitor	2	V
1E	OPF_TMI		Servo Amplifier Operation Time	10	x2 hour

For how to operate these, refer to “R-SETUP Instruction Manual.”

■ Using auto-tuning result at manual tuning.

At manual tuning, auto-tuning result is saved as a batch or by selection using R-SETUP, and can be used as controlling parameter.

Save Result of Automatic Tuning [#1 : R51L01AA]

Tuning Mode
 TUNMODE : Manual Tuning
 ATCHA : Positioning Control 1

Setting
 Setting Parameter : KP1,KVP1,TVI1,TCFIL1,JRAT1
 ATRES : 20

Parameter Monitor Value of Automatic Tuning
 KP : 98 [1/s]
 KVP : 93 [Hz]
 TVI : 10.7 [ms]
 TCFIL : 689 [Hz]
 JRAT : 100 [%]

Parameter Setting Value
 KP1 : 30 [1/s]
 KVP1 : 50 [Hz]
 TVI1 : 20.0 [ms]
 TCFIL1 : 600 [Hz]
 JRAT1 : 100 [%]

⚠ ATRES can be changed on this window. However, the changed value is not saved as a parameter. ATRES returns to former setting value when this window is closed.

Data type of Monitor Value is changed by Tuning Mode (TUNMODE) and Automatic Tuning Characteristic (ATCHA).
 Manual Tuning : Proper gain by Automatic Tuning Function.
 Automatic Tuning : Real using gain in control loop.
 JRAT, KVP, TVI, TCFIL : Proper gain by Automatic Tuning Function.
 KP : When ATCHA is not Trajectory Control 2, Proper gain by Automatic Tuning Function.
 When ATCHA is Trajectory Control 2, KP1 setting value.
 Automatic Tuning (JRAT fixed) : Real using gain in control loop.
 JRAT : JRAT1 setting value.
 KVP, TVI, TCFIL : Proper gain according to JRAT1.
 KP : When ATCHA is not Trajectory Control 2, Proper gain according to JRAT1.
 When ATCHA is Trajectory Control 2, KP1 setting Value.

For how to operate these, refer to “R-SETUP Instruction Manual.”

Note) In the setting of TUNMODE=02:_ManualTun, parameter setting value is used in the control loop. When auto-tuning result saving is executed, the gain parameter being used will change (except during gain switch over). Therefore, the motor operation may change suddenly. Execute auto-tuning result saving while servo OFF or motor stoppage.

7.Adjustment·Functions

[Servo gain tuning]

■ Servo system configuration

Servo system consists of 3 subsystems; the position loop, the velocity loop and the current loop. High response is required for the internal loops. If this structure is compromised, it could result in instability, low response, vibration or oscillation.

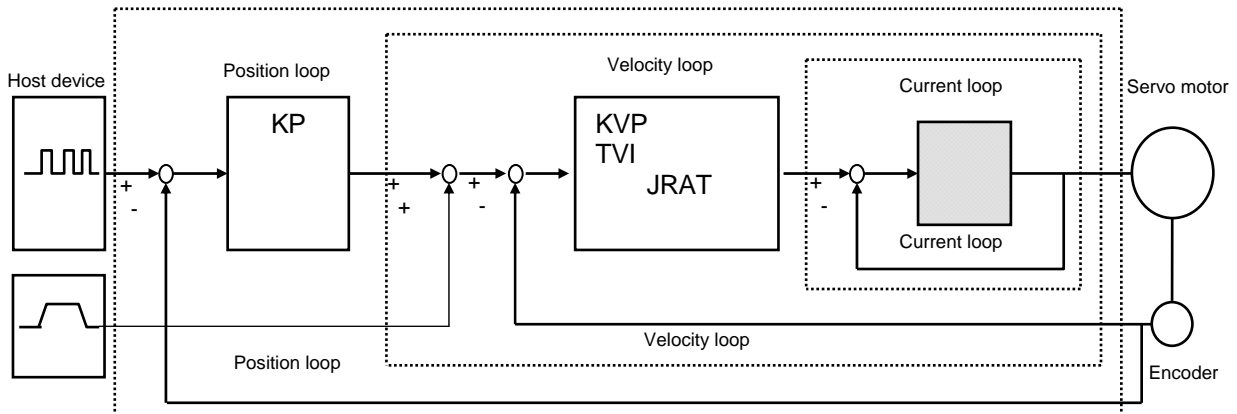

The response of the current loop is ensured internally in the servo amplifier, there is no need for the user to make additional adjustments.

■ Servo adjustment parameters

Position Command Filter [PCFIL]

When the position command resolution is low, set this parameter to suppress the ripples contained in the position command. The larger value of this will make the ripple suppressing effect greater, however, delay will be greater.

* When high tracking control position compensation gain is set to other than 0%, this parameter is automatically set.

Position Loop Proportional Gain [KP]

Set this equivalent to $KP_{[1/S]} = KVP_{[Hz]} / 4 \cdot 2\pi$.

Higher Tracking Control, Position Compensation Gain [TRCPGN]

When tracking effect needs to be improved under high resolution of position command, increase this parameter after adjustment of high tracking control velocity compensation gain.

Feed Forward Gain [FFGN]

Tracking effect of position command can be improved by increasing this gain. Under positioning control, set this to approximately 30 to 40%.

* When high tracking control position compensation gain is set to other than 0%, this parameter is automatically set.

Feed Forward Filter [FFFIL]

When position command resolution is low, set this parameter to suppress ripples.

Velocity Command Filter [VCFIL]

Under velocity control, when there is a big noise component contained in velocity command, set this parameter to suppress the noise.

Velocity Loop Proportional Gain [KVP]

Set this as high as possible within such a stable operation range as not to cause vibration or oscillation of the machine. If JRAT is accurately set, the set value of KVP becomes the velocity loop response zone.

Velocity Loop Integral Time Constant [TVI]

Set this equivalent to $TVI_{[ms]} = 1000 / (KVP_{[Hz]})$.

Load Inertia Ratio [JRAT]

Set the value calculated as shown below.

$$JRAT = \frac{\text{Motor axis converted load inertia moment [JL]}}{\text{Motor inertia moment [JM]}} \times 100\%$$

Higher Tracking Control, Velocity Compensation Gain [TRCVGN]

Tracking effect can be improved by increasing compensation gain.

Adjust this so as to shorten the positioning setting time.

- * Set the value of JRAT properly to use this function.

Torque Command Filter 1 [TCFIL]

When rigidity of the mechanical device is high, set this value high and the velocity loop proportional gain can be set to high. When rigidity of the mechanical device is low, set this value low and resonance in high frequency zone and abnormal sound can be suppressed. For normal usage, set this below 1200Hz.

■ Adjustment method of vibration suppressing control

Set vibration suppressing frequency to suppress the low frequency vibration at the tip or the body of the machine. Vibration suppressing frequency is obtained by executing auto-tuning of vibration suppressing frequency or by calculating vibration frequency of vibrating point at positioning and its reciprocal. When vibration does not stop with the vibration suppressing control, there is a possibility that the gain for control system may be too high. In this case, lower the control system gain. Also, when used together with high tracking control velocity compensation gain, vibration suppressing effect may be greater.

- * Vibration suppressing control function can be used together with auto-tuning.

■ Adjustment method of notch filter

Set the torque command notch filter to suppress high frequency resonance resulted from coupling and rigidity of the device mechanism. Notch filter center frequency can be obtained by executing auto-notch filter tuning or by system analysis.

- * Torque command notch filter function can be used together with auto-tuning.
- * When resonance of the device mechanism does not stop even after this parameter is set, there may be two or more resonance points. In this case, insert notch filters B, C and D to suppress each of them. If not yet suppressed, there is a possibility that auto-tuning response or control gain is too high. If so, lower the auto-tuning response or control gain.

■ Adjustment method of disturbance observer

Set the disturbance observer to suppress the disturbance applied to the motor.

At first, use the low frequency observer characteristics. If not suppressed by that, use that for medium frequency. Gradually increase the observer compensation gain.

The higher the observer compensation gain becomes, the more the disturbance suppressing characteristics will be improved. However, if it is excessively high, oscillation may result. Use this within the range not causing oscillation.

- * Disturbance observer cannot be used with auto-tuning.

■ Adjustment method of gain switch over

When tracking effect is insufficient even if basic parameters of high tracking control position compensation gain and high tracking control velocity compensation gain are set, set the gain switch over so that tracking effect can be improved.

<Example> Gain is increased near positioning complete.

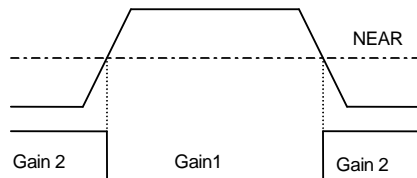

The value of gain 2 shall be set to 1.2 times the value of gain 1.

* Gain switch over function cannot be used with auto-tuning.

■ Adjustment method of high setting control

When tracking effect is insufficient even after gain switch over, set the high setting control parameter and in-position setting characteristics can be improved. When position command resolution is low, set the value of command velocity calculation low pass filter low. Set the acceleration compensation so that the position deviation near acceleration conclusion becomes small. Set the deceleration compensation so that the position deviation near deceleration conclusion (positioning complete) becomes small.

* This function cannot be used together with auto-tuning.

■ How to make R series control characteristics equal to Q-series standard characteristics

Parameter change as follows can make the status equal to Q-series standard characteristics.

Group	Page		Before change	After change
0	00	Tuning Mode	00:_AutoTun	02:ManualTun
1	16	Higher Tracking Control, Velocity Compensation Gain	0%	100%

7.Adjustment·Functions

Functions of Group 8 Position command pulse

■ Functions of Group 8

[Group 8] 00

Command Input Polarity [CMDPOL] Velocity control mode Position control mode Torque control mode

The rotation direction of the servo motor can be reversed without modifying the input command wiring or the servo motor wiring.

Input command	Command polarity	Rotation direction	Selected value
Position command	+	Forward	00:_PC+_VC+_TC+
Velocity command	+	Forward	
Torque command	+	Forward	

Input command	Command polarity	Rotation direction	Selected value
Position command	+	Reverse	04:_PC-_VC+_TC+
Velocity command	+	Forward	
Torque command	+	Forward	

Input command	Command polarity	Rotation direction	Selected value
Position command	+	Forward	01:_PC+_VC-_TC-
Velocity command	+	Forward	
Torque command	+	Reverse	

Input command	Command polarity	Rotation direction	Selected value
Position command	+	Reverse	05:_PC-_VC-_TC-
Velocity command	+	Forward	
Torque command	+	Reverse	

Input command	Command polarity	Rotation direction	Selected value
Position command	+	Forward	02:_PC+_VC-_TC+
Velocity command	+	Reverse	
Torque command	+	Forward	

Input command	Command polarity	Rotation direction	Selected value
Position command	+	Reverse	06:_PC-_VC-_TC+
Velocity command	+	Reverse	
Torque command	+	Forward	

Input command	Command polarity	Rotation direction	Selected value
Position command	+	Forward	03:_PC+_VC-_TC-
Velocity command	+	Reverse	
Torque command	+	Reverse	

Input command	Command polarity	Rotation direction	Selected value
Position command	+	Reverse	07:_PC-_VC-_TC-
Velocity command	+	Reverse	
Torque command	+	Reverse	

* Using the initial factory settings, the servo motor rotates in the forward (CCW) direction with a positive (+) input, and in the reverse (CW) direction with a negative (-) input.

Standard command input polarity setting

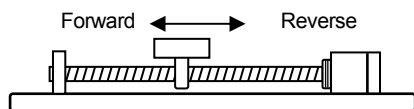

+input=forward (CCW) -input=reverse(CW)



Modified command input polarity setting

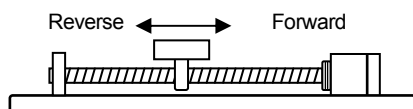

+input=reverse (CW) -input=forward (CCW)



7.Adjustment·Functions

[Functions of Group 8][Position command pulse]

[Group 8] 11

Position Command Pulse, Form Selection [PCPTYP]

Position control mode

3 types of location command pulse can be selected; make this selection per the specifications of the host unit.

Selected value	Contents
00: _F-PC_R-PC	Positive Move Pulse + Negative Move Pulse
01: _2PhasePulse	Two-Phase Pulse Train of 90 Degrees Phase Difference
02: _CODE_PC	Code + Pulse Train

The location command pulse input command is the input command used for location control. Connect to CN1 location command pulse input.

Forward	Reverse
Positive Move Pulse (F-PC): CN1-26	Negative Move Pulse (R-PC): CN1-28
Positive Move Pulse (F-PC): CN1-27	Negative Move Pulse (R-PC): CN1-29
Positive Move Pulse SG: CN1-47	Negative Move Pulse SG: CN1-48

There are 2 output types for the host unit, the "Line driver output" and the "Open collector output".

Using line driver output

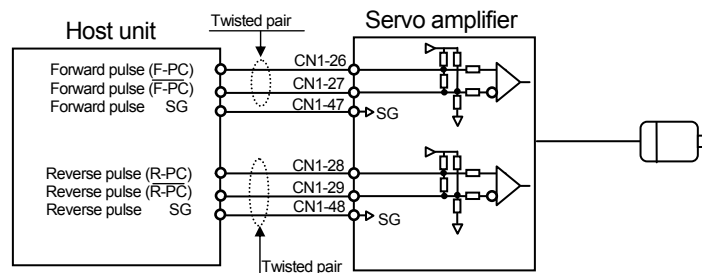

- * Always connect SG.
- * Line Receiver: HD26C32 or equivalent

Using open collector output

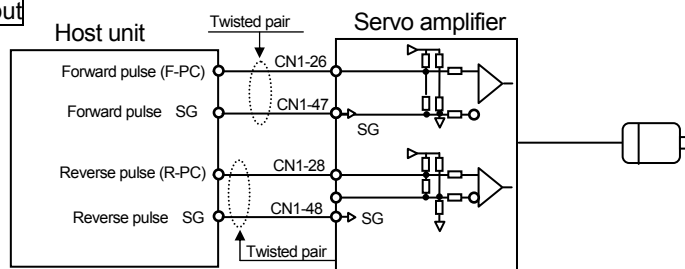

- * Always connect SG.
- * Line Receiver: HD26C32 or equivalent

7.Adjustment·Functions

Functions of Group 8[Position command pulse]

[Group 8] 12

Position Command Pulse, Count Polarity [PCPPOL]

Position control mode

Position command pulse count polarity can be selected from the following 4 types.
Select the one suitable for the host unit.

Selected value	Contents
00: Type1	F-PC/ Count at the Rising Edge: R-PC/ Count at the Rising Edge
01: Type2	F-PC/ Count at the Falling Edge: R-PC/ Count at the Rising Edge
02: Type3	F-PC/ Count at the Rising Edge: R-PC/ Count at the Falling Edge
03: Type4	F-PC/ Count at the Falling Edge: R-PC/ Count at the Falling Edge

[Group 8] 13

Position Command Pulse, Digital Filter [PCPFIL]

Position control mode

When the time for minimum pulse width at position command input maximum frequency is less than the digital filter set value, alarm "AL D2" will be issued. Set the smaller value for digital filter than the time of minimum pulse width at the time of position command input maximum frequency. Select the position command pulse digital filter setting from the followings according to the command pulse type of the unit in use.

Forward pulse string + Reverse pulse string

Selected value	Minimum pulse width [t]	Position command input maximum frequency[f]
00	t > 834nsec	f < 599Kpps
01	t > 250nsec	f < 2.0Mpps
02	t > 500nsec	f < 1.0Mpps
03	t > 1.8μsec	f < 277Kpps
04	t > 3.6μsec	f < 138Kpps
05	t > 7.2μsec	f < 69Kpps
06	t > 125nsec	f < 4Mpps
07	t > 83.4nsec	f < 5.9Mpps

90°-phase difference 2 phase pulse

Selected value	A-phase·B-phase Minimum edge interval [t]	Position command input maximum frequency[f]
00	t > 834nsec	f < 599Kpps
01	t > 250nsec	f < 2.0Mpps
02	t > 500nsec	f < 1.0Mpps
03	t > 1.8μsec	f < 277Kpps
04	t > 3.6μsec	f < 138Kpps
05	t > 7.2μsec	f < 69Kpps
06	t > 164nsec	f < 1.5Mpps
07	t > 164nsec	f < 1.5Mpps

Code + pulse string

Selected value	Minimum pulse width [t]	Position command input maximum frequency[f]
00	t > 834nsec	f < 599Kpps
01	t > 250nsec	f < 2.0Mpps
02	t > 500nsec	f < 1.0Mpps
03	t > 1.8μsec	f < 277Kpps
04	t > 3.6μsec	f < 138Kpps
05	t > 7.2μsec	f < 69Kpps
06	t > 125nsec	f < 4Mpps
07	t > 83.4nsec	f < 5.9Mpps

7.Adjustment·Functions

[Functions of Group 8][Position command pulse]

Command pulse	Command pulse timing		
Positive Move Pulse + Negative Move Pulse			
Two-Phase Pulse Train of 90 Degrees Phase Difference			
Code + Pulse Train			
	Positive Move Pulse + Negative Move Pulse	Two-Phase Pulse Train of 90 Degrees Phase Difference	Code + Pulse Train
t1·t8	$\leq 0.1\mu\text{s}$	$\leq 0.1\mu\text{s}$	$\leq 0.1\mu\text{s}$
t2·t9	$\leq 0.1\mu\text{s}$	$\leq 0.1\mu\text{s}$	$\leq 0.1\mu\text{s}$
ts1·ts2 ts3·ts4	$> 2\mu\text{s}$	-	$> 2\mu\text{s}$
t4·t5 t6·t7	-	$> 250\text{ns}$	-
(t3/T) x100	50%	50%	50%

7.Adjustment·Functions

[Functions of Group 8][Electronic gear·Positioning method]

[Group 8]15,16

Electric Gear Ratio * [GER*]

Position control mode

This function allows a distance setting on the servo motor in reference to the location command pulse from the unit.

Setting range	Unit	Standard set value
1/32767 to 32767/1	-	1/1

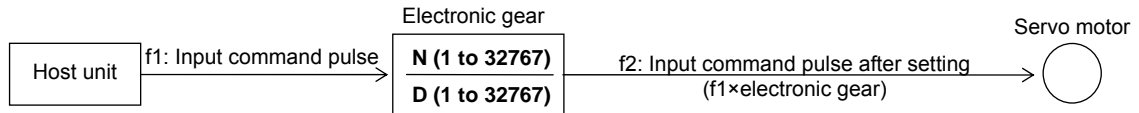

$$\text{Electronic gear setting range: } \frac{1}{32767} \leq \frac{N}{D} \leq \frac{32767}{1}$$

Refer to "Materials; Electronic Gear."

[Group 8] 17

Positioning Method [EDGEPOS]

Position control mode

The location of positioning stop is selected; between encoder pulses or at edge.

Selected value	Contents
00: Pulse_Interval	Specify Pulse Interval
01: Pulse_Edge	Specify Pulse Edge

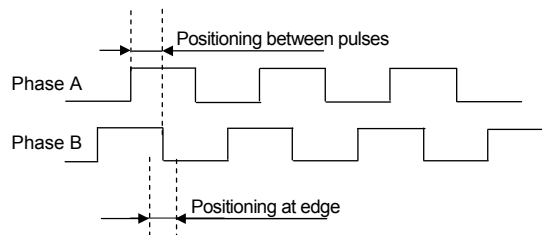

[Group 8] 18

Inposition/ Position Deviation Monitor [PDEVMON]

Position control mode

Positioning complete signal when the position control mode is used, and position command used for outputting position deviation monitor can be selected from before or after the position command filter passes.

Selected value	Contents
00: After_Filter	Compare "Position Command Value After Filter Passes by" with "Feedback Value"
01: Before_Filter	Compare "Position Command Value Before Filter Passes by" with "Feedback Value"

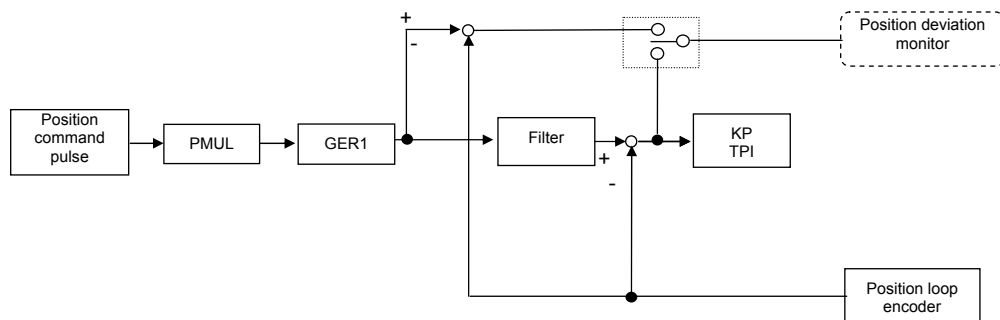

7.Adjustment・Functions

[Group 8] 19

Deviation Clear Selection [CLR]

Position control mode

This function is used for changing the location deviation counter in the servo amplifier from the host unit to zero.

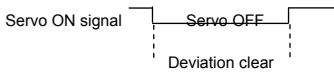
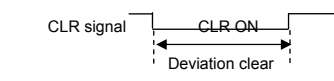
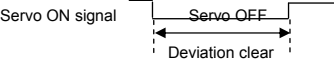
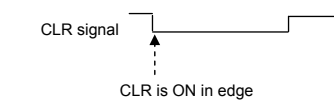
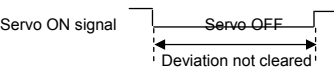
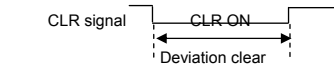
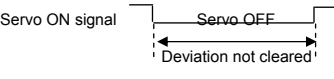
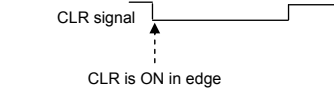
Selection		Description
0H	When SERVO-OFF/ Clear Deviation: Deviation Clear Input/ Level Detection	<ul style="list-style-type: none"> Deviation is always cleared when servo is off.  <p>Logic can be changed</p> <ul style="list-style-type: none"> Deviation is always cleared when deviation clear input is ON.  <p>Logic cannot be changed</p>
1H	When SERVO-OFF/ Clear Deviation: Deviation Clear Input/ Edge Detection	<ul style="list-style-type: none"> Deviation is always cleared when servo is off.  <p>Logic can be changed</p> <ul style="list-style-type: none"> Deviation is cleared in the edge when deviation clear input becomes OFF/ON.  <p>CLR is ON in edge</p> <p>Logic can be changed</p>
2H	When SERVO-OFF/ Not Clear Deviation: Deviation Clear Input/ Level Detection	<ul style="list-style-type: none"> Deviation is not cleared when servo is OFF. The motor may start suddenly after servo is turned ON with location deviation detected.  <p>Logic can be changed</p> <ul style="list-style-type: none"> Deviation is cleared in the edge when deviation clear input becomes OFF/ON.  <p>Logic cannot be changed</p>
3H	When SERVO-OFF/ Not Clear Deviation: Deviation Clear Input/ Edge Detection	<ul style="list-style-type: none"> Deviation is not cleared when servo is OFF. The motor may start suddenly after servo is turned ON with location deviation detected.  <p>Logic can be changed</p> <ul style="list-style-type: none"> Deviation is cleared in the edge when deviation clear input becomes OFF/ON.  <p>CLR is ON in edge</p> <p>Logic cannot be changed</p>

Select the conditions for enabling deviation clear.

Parameter Group9 page04

CLR: Deviation Clear Function

7.Adjustment·Functions

[Functions of Group 8][Internal velocity command]

[Group 8] 20 to 22

Preset Velocity Command 1 to 3 [VC*]

Velocity control mode

The servo motor can be controlled using Preset Velocity Command. Preset Velocity Command settings have 3 ways. Preset Velocity Command and rotation direction can be selected via conditions of general input CONT1 to CONT8.

1. Set the Preset Velocity Command value.

Parameter Group8Page20	VC1: Preset Velocity Command 1	0 to 32767min ⁻¹
Parameter Group8Page21	VC2: Preset Velocity Command 2	0 to 32767min ⁻¹
Parameter Group8Page22	VC3: Preset Velocity Command 3	0 to 32767min ⁻¹

2. Select the conditions for enabling the Preset Velocity Command. The Preset Velocity Command requires the selection of valid conditions.

Parameter Group9Page20	SP1: Preset Velocity Command, Select Input 1
Parameter Group9Page21	SP2: Preset Velocity Command, Select Input 2

SP1: Preset Velocity Command, Select Input 1 SP2: Preset Velocity Command, Select Input 2	Valid Invalid	→	VC1: internal velocity command 1
SP1: Preset Velocity Command, Select Input 1 SP2: Preset Velocity Command, Select Input 2	Invalid Valid	→	VC2: internal velocity command 2
SP1: Preset Velocity Command, Select Input 1 SP2: Preset Velocity Command, Select Input 2	Valid Valid	→	VC3: internal velocity command 3
SP1: Preset Velocity Command, Select Input 1 SP2: Preset Velocity Command, Select Input 2	Invalid Invalid	→	Analog velocity command

3. Begin operation with the Preset Velocity Command and select the conditions for rotation direction.

Parameter Group9Page22	DIR: Preset Velocity Command, Direction of Move
Parameter Group9Page23	RUN: Preset Velocity Command, Operation Start Signal Input
Parameter Group9Page24	RUN-F: Preset Velocity Command, Positive Move Signal Input
Parameter Group9Page25	RUN-R: Preset Velocity Command, Negative Move Signal Input

4. If the above conditions are valid, run the servo motor with the selection combinations listed below.

RUN: Preset Velocity Command, Operation Start Signal Input	Valid	Servo motor moves forward
DIR: Preset Velocity Command, Direction of Move	Invalid	
RUN: Preset Velocity Command, Operation Start Signal Input	Valid	Servo motor in reverse
DIR: Preset Velocity Command, Direction of Move	Valid	
RUN-F: Preset Velocity Command, Positive Move Signal Input	Valid	Servo motor moves forward
RUN-R: Preset Velocity Command, Negative Move Signal Input	Valid	Servo motor in reverse

7.Adjustment·Functions

[Functions of Group 8][Internal velocity command]

Examples of setting and operation pattern at the Preset Velocity Command operation.

VC1: Preset Velocity Command 1	1000min ⁻¹
VC2: Preset Velocity Command 2	2000min ⁻¹
VC3: Preset Velocity Command 3	3500min ⁻¹

SP1: Preset Velocity Command, Select Input 1	Enable the function when general purpose input CONT3 is ON.
SP2: Preset Velocity Command, Select Input 2	Enable the function when general purpose input CONT4 is ON.

RUN-F: Preset Velocity Command, Positive Move Signal Input	Enable the function when general purpose input CONT5 is ON.
RUN-R: Preset Velocity Command, Negative Move Signal Input	Enable the function when general purpose input CONT5 is OFF.

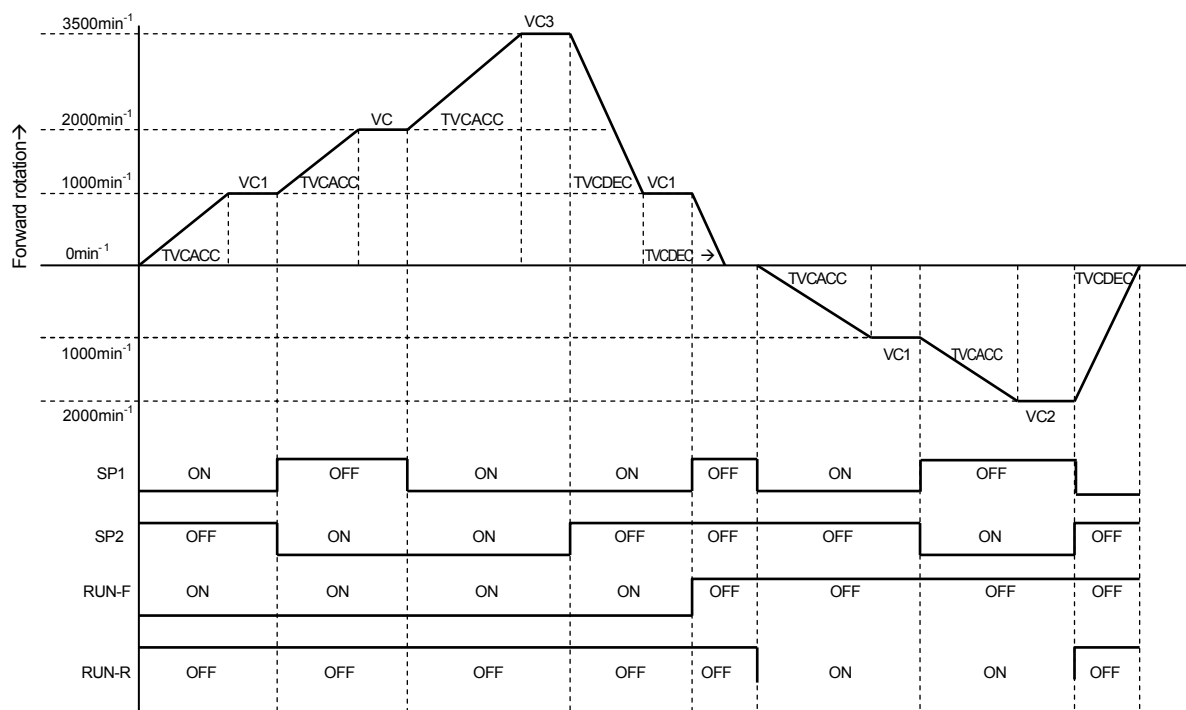

7.Adjustment·Functions

[Functions of Group 8][Velocity addition command]

[Group 8] 23 to 25

Velocity Compensation Command, Input Selection [VCOMSEL]/
Preset Velocity Compensation Command [VCOMP]
Analog Velocity (Compensation) Command, Reference [VCGN]

Position control mode

The velocity compensation addition function is the fast-forward function in the velocity control system. The Velocity Compensation Command, Input Selection has 2 settings: the Preset Velocity Compensation Command and the Analog Velocity Compensation Command. The Preset Velocity Compensation Command is used when the velocity compensation command value is a fixed value. The Analog Velocity Compensation Command is used when setting the velocity compensation command input value from the host unit.

1. Set the Preset Velocity Compensation Command value.

Parameter Group8 Page24	VCOMP: Preset Velocity Compensation Command	-9999 to +9999 min ⁻¹
-------------------------	---	----------------------------------

2. Select the Velocity Compensation Command input method.

Parameter Group8 Page23	VCOMSEL: Velocity Compensation Command, Input Selection
-------------------------	---

Selection		Description
01:_Analog_Input	Apply Analog Velocity Compensation Command	Use analog velocity addition command value when velocity addition function is valid.
02:_VCOMP	Apply Preset Velocity Compensation Command	Use internal velocity addition command value when velocity addition function is valid.

3. Select the condition for enabling the Velocity Compensation Function and then input the setting.

Parameter Group9 Page27	VCOMPS: Velocity Compensation Function, Select Input
-------------------------	--

1. Set the Analog Velocity Compensation Command, Reference.
(This is shared with Analog Velocity Command, Reference.)

Parameter group 8 page 25	VCGN: Analog Velocity Command, Reference	0 to 4000 min ⁻¹ /V
---------------------------	--	--------------------------------

The input used in the Analog Velocity Compensation Command is the same as the Analog Velocity Command / Analog Torque Command input.

Analog Velocity Compensation Command input: CN1-21 [Input voltage range -10V to +10V]

Analog Velocity Compensation Command input SG: CN1-20

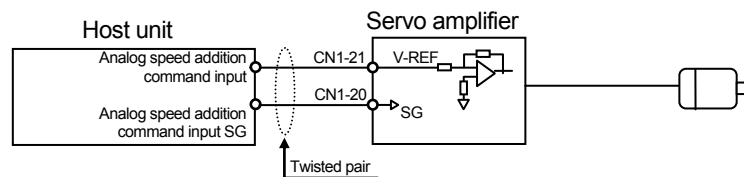

2. Select the Velocity Compensation Command input method.

Parameter Group8 Page23	VCOMSEL: Velocity Compensation Command Input Selection
-------------------------	--

Selection		Description
01:_Analog_Input	Apply Analog Velocity Compensation Command	Use Analog Velocity Compensation Command value when Velocity Compensation Function is valid.
02:_VCOMP	Apply Preset Velocity Compensation Command	Use Preset Velocity Compensation Command value when Velocity Compensation Function is valid.

3. Select the conditions for enabling the velocity addition function.

Parameter Group9 Page27	VCOMPS: Velocity Compensation Function, Select Input
-------------------------	--

7.Adjustment·Functions

[Functions of Group 8][Velocity addition command]

[Group 8] 26 to 27

Velocity Command, Acceleration Time Constant. [TVCACC]

Velocity Command, Deceleration Time Constant. [TVCDEC]

Velocity control mode

The step input velocity command can be changed to a constant acceleration/deceleration velocity command using the Velocity Command, Acceleration/ Deceleration Time Constant.

Acceleration/deceleration time per $\pm 1000 \text{min}^{-1}$ is set.

Parameter Group8Page26	TVCACC: Velocity Command, Acceleration Time Constant.	0 to 16000 ms
Parameter Group8Page27	TVCDEC: Velocity Command, Deceleration Time Constant.	0 to 16000 ms

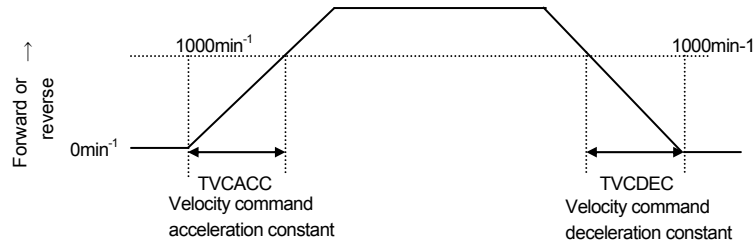

The Analog Velocity Command, Preset Velocity Command, and JOG operation can be used together.

[Group 8] 28

Velocity Limit [VCLM]

Velocity control mode Position control mode

Host limit value can be locked in with the velocity limit command.

This value cannot be set to exceed the velocity capabilities of the adjoining motor.

Parameter Group8Page28	VCLM: Velocity Limit	1 to 65535 min^{-1}
------------------------	----------------------	------------------------------

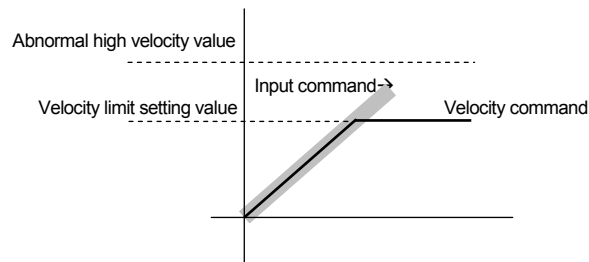

7.Adjustment·Functions

[Functions of Group 8][Torque addition command]

[Group 8] 30 to 34

Torque Compensation Command, Input Selection [TCOMSEL]
 Analog Torque Compensation Command, Reference [TCOMPGN]
 Preset Torque Compensation Command 1 [TCOMP1]
 Preset Torque Compensation Command 2 [TCOMP2]
 Torque Compensation Function, Select Input 1 [TCOMPS1]
 Torque Compensation Function, Select Input 2 [TCOMPS2]

Velocity control mode Position control mode

The torque addition function is the fast-forward function of the torque control system. There are 2 types of settings for the torque addition command input function: the internal torque addition command and the analog torque addition command. The internal torque addition command can be used when using the torque addition command value as a fixed value. The analog torque addition command can be used when setting the torque addition command input value from the host unit.

1. Sets the internal torque addition command value.

Parameter Group8Page31	TCOMP: Preset Torque Compensation Command 1	-500 to +500 %
Parameter Group8Page32	TCOMP: Preset Torque Compensation Command 2	-500 to +500 %

2. Select the torque addition command input method.

Parameter Group8Page30	TCOMSEL: Torque Compensation Command, Input Selection
------------------------	---

Selection		Description
1H	Apply Analog Torque Compensation Command	Use analog torque addition command value when torque addition function is valid.
2H	Apply Preset Torque Compensation Command	Use internal torque addition command value when torque addition function is valid.

3. Select the condition for enabling the torque addition function and then input the setting.

Parameter Group9Page30	TCOMPS1: Torque Compensation Function, Select Input 1
Parameter Group9Page31	TCOMPS2: Torque Compensation Function, Select Input 2

1. Sets the analog torque addition command scaling.

Parameter Group8Page34	TCOMPGN: Analog Torque Compensation Command, Reference	0 to 500 %
------------------------	--	------------

2. The input used in the analog torque addition command provides the signal analog torque addition command input of CN1.

Analog torque addition command input: CN1-22 [Input voltage range: -10V to +10V]

Analog torque addition command input SG: CN1-23

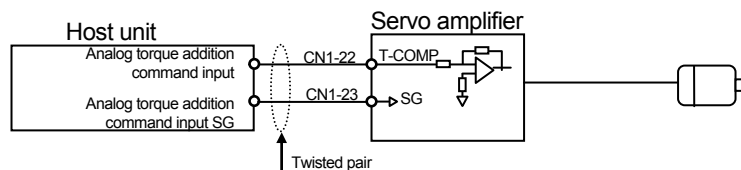

3. Select the torque addition command input method.

Parameter Group8Page30	TCOMSEL: Torque Compensation Command, Input Selection
------------------------	---

Selection		Description
1H	Apply Analog Torque Compensation Command	Use analog torque addition command value when torque addition function is valid.
2H	Apply Preset Torque Compensation Command	Use internal torque addition command value when torque addition function is valid.

4. Select the conditions for enabling the torque addition function.

Parameter Group9Page30	TCOMPS1: Torque Compensation Function, Select Input 1
Parameter Group9Page31	TCOMPS2: Torque Compensation Function, Select Input 2

7.Adjustment·Functions

[Group 8] 35 to 36

Torque Limit, Input Selection [TLSEL]

Internal Torque Limit [TCLM]

Velocity control mode Position control mode Torque control mode

There are two areas where selections for the torque limit function can be made: the internal torque limit and the external torque limit. The two selections have different settings, and affect the operation of the unit in different ways.

Internal torque limit

- The internal torque limit (constant) can be used to limit the maximum torque and protect the machine and equipment. Set these parameters according to the following table.

Parameter Group8 Page35	TLSEL: Torque Limit, Input Selection
-------------------------	--------------------------------------

Selection value		Description
00:_TCLM	Apply Internal Torque Limit Value. (TCLM)	Forward (positive direction): limited by internal constant. Reverse (reverse direction) : limited by internal constant.

- Internal torque limit value setting

Parameter Group8 Page36	TCLM: Internal Torque Limit	10 to 500%
-------------------------	-----------------------------	------------

- Torque limit function enable

Parameter Group9 Page32	TL: Torque limit function
-------------------------	---------------------------

Conditions for enabling torque limit permission function are selected. When conditions are valid, torque limit is permitted and operation starts.

- * If the value is set higher than the maximum output torque (T_P) of the servo motor, it will be limited by (T_P).
- * Set this value after considering the acceleration time. Too low of a setting can result in insufficient acceleration torque and poor control.
- * The internal torque limit should be set higher than the acceleration torque.
- * The internal torque limit is identical for forward and reverse rotation. Separate torque limits cannot be set.

External torque limit

With the external torque limit function, separate torque limits can be set for forward and reverse rotation. There is a designated input for external torque limit on the CN1 input signal.

Forward torque limit input (F-TLA) : CN1-18 [Input voltage range 0V to +10V]

Reverse torque limit input (R-TLA) : CN1-19 [Input voltage range -10V to +10V]

SG : CN1-17

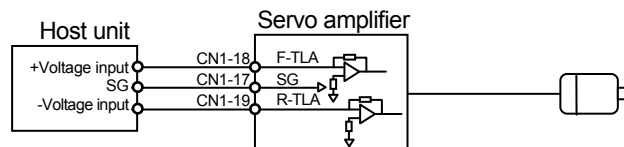

7.Adjustment·Functions

The input voltage specification and the input signal specification can be used in three ways.

Parameter Group8Page35 TLSEL: Torque Limit, Input Selection

Selection value		Description
01:_Analog_1	Apply External Input: Positive Move/ F-TLA. Negative Move/ R-TLA (- Volt Input).	Forward: The limit will be the positive voltage input to F-TLA. Reverse: The limit will be the negative voltage input to R-TLA.
02:_Analog_2	Apply External Input: Positive Move/ F-TLA. Negative Move/ R-TLA (+ Volt Input).	Forward: The limit will be the positive voltage input to F-TLA. Reverse: The limit will be the positive voltage input to R-TLA.
03:_Analog_3	Apply External Input: Positive Move/ F-TLA. Negative Move/ F-TLA.	Forward: The limit will be the positive voltage input to F-TLA. Reverse: The limit will be the positive voltage input to F-TLA.

01:_Analog_1

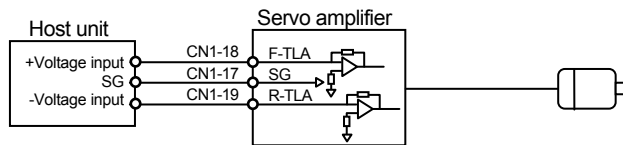

02:_Analog_2

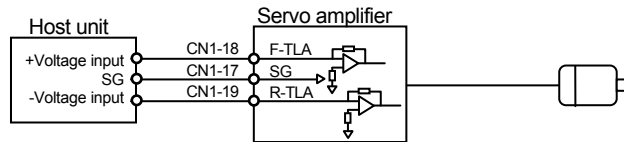

03:_Analog_3

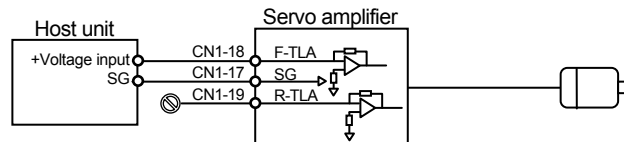

Connect the voltage corresponding to the torque limit to the external torque input pin. The relationship between the input voltage and the limitable torque is the rated torque (TR) = 2V for the type of servo motor used.

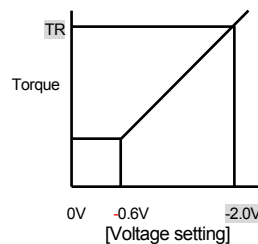
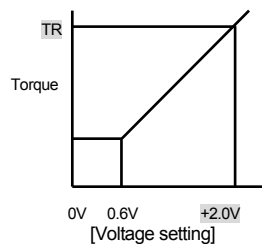

Torque limit function enable

Parameter Group9Page32 TL: Torque Limit, Input Selection

Conditions for enabling torque limit permission function are selected. When conditions are valid, torque limit is permitted and operation starts.

7.Adjustment·Functions

[Functions of Group 8][Sequence operation torque limit]

[Group 8] 37

Torque Limit at Sequence Operation [SQTCLM]

Velocity control mode Position control mode Torque control mode

During the sequence operation the output torque is limited. Limiting the output torque protects the unit mechanism.

The torque limits during sequence operation support the following sequence operations:

- JOG operation
- Over travel operation
- Holding brake standby time
- Servo brake operation

Sequence operation torque limit value setting

Parameter Group 8 Page37	SQTCLM: Torque Limit at Sequence Operation	10 to 500%
--------------------------	--	------------

If this value is set higher than the maximum output torque (TP) of the servo motor, it will be limited by (TP).

7.Adjustment·Functions

[Group 8] 40

In-Position Near Range [NEAR]

Position control mode

Outputs signal indicating proximity to position completion.

This is used together with positioning complete signal (INP) and near range of positioning complete is output.

Parameter Group8Page40 | NEAR: In-Position Near Range | 1 to 65535 Pulse

Parameter GroupAPage0 * | OUT*: General Purpose Output *

Selection	Description	
1A	NEAR_ON	The output is ON during In-Position Near status (position deviation < NEAR).
1B	NEAR_OFF	The output is OFF during In-Position Near status (position deviation < NEAR).

Determine the logical status of the NEAR signal output, and to which output terminal to assign the positioning completion signal output. The assignment of the output terminal is the same location as the positioning completion signals (above).

If set to a value greater than the positioning completion range settings, the host unit receives the NEAR signal before receiving the positioning completion signal (INP), and transition to the positioning completion operations is enabled.

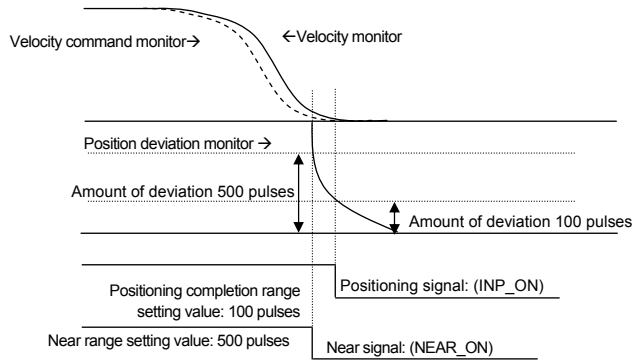

7.Adjustment·Functions

[Functions of Group 8][Positioning complete range]

[Group 8] 41

In-Position Window [INP]

Position control mode

The positioning completion signal is output from the selected output terminal when servo motor movement is completed (reaches the set deviation counter value) during location control mode.
Setting the positioning completion range

Parameter Group8Page41 | INP: In-Position Window | 1 to 65535 Pulse

Set the deviation counter value with positioning completion signals. The encoder pulse is standard, irrespective of the command pulse multiplication and electronic gear settings.

Incremental encoder: 4 times (4x) encoder pulses is standard.

Absolute encoder: Absolute value is standard.

Setting the positioning completion signal

Parameter GroupA Page0* | OUT*: General Purpose Output *

Selection	Description
18 INP_ON	The output is ON during In-Position status (position deviation < INP).
19 INP_OFF	The output is OFF during In-Position status (position deviation < INP).

Determine the logical status of the positioning completion signal output, and to which output terminal to assign the positioning completion signal output.

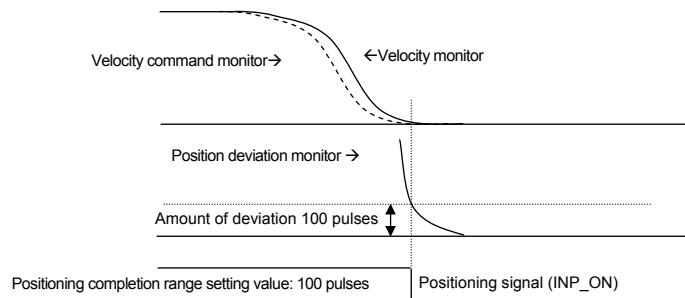

7.Adjustment·Functions

[Functions of Group 8][Velocity setting]

[Group 8] 43 to 45

Low Speed Range [LOWV]

Speed Matching Width [VCMP]

High Speed Range [VA]

Position control mode Velocity control mode Torque control mode

This parameter affects settings for the speed output range. The signal can be output from general output (OUT1 to OUT8) and used as a valid condition for all functions. However, the speed coincidence range is invalid in torque control mode.

To direct signals to the host unit, make assignments to the signals in parameter Group 9. Use the general output terminal (OUT1 to OUT8) of the connected CN1.

Parameter GroupA Page0 * OUT*: General Purpose Output *

Selection	Description
10 LOWV_ON	The output is ON during low speed status (speed is less than LOWV).
11 LOWV_OFF	The output is OFF during low speed status (speed is less than LOWV).
12 VA_ON	The output is ON during high speed status (speed is more than VA).
13 VA_OFF	The output is OFF during high speed status (speed is more than VA).
14 VCMP_ON	The output is ON during speed matching status (speed deviation < VCMP).
15 VCMP_OFF	The output is OFF during speed matching status (speed deviation < VCMP).

Low speed range: Low speed signal is sent if speed goes below the set value.

Parameter Group8 Page43 LOWV: Low speed range 0 to 65535min⁻¹

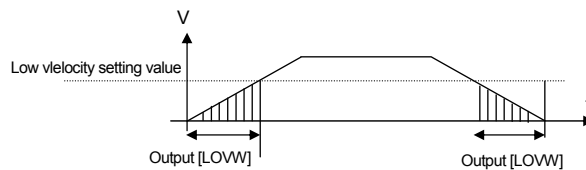

Speed Matching Width: Speed coincidence range signal is given if speed deviation reaches the set range.

Parameter Group8 Page44 VCMP: Speed Matching Width 0 to 65535min⁻¹

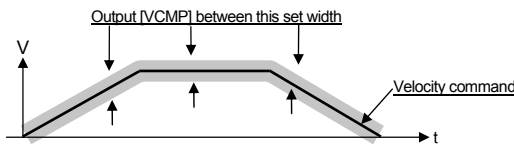

Speed transport settings: Speed transport signal is given if speed exceeds the set value.

Parameter Group1 Page08 VA: High Speed Range 0 to 65535min⁻¹

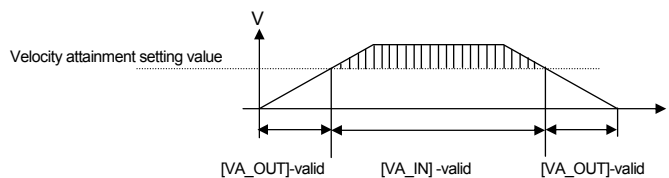

7.Adjustment·Functions

[Functions of Group 8][Velocity setting]

Various functions can be made valid without output signals taken into the host unit when this is used together with Group9 function enabling conditions (input signals).

Selection	Description
12 LOWV_IN	Enable the function during low speed status (speed is less than LOWV).
13 LOWV_OUT	Enable the function while low speed status is not kept.
14 VA_IN	Enable the function during high speed status (speed is more than VA).
15 VA_OUT	Enable the function while high speed status is not kept.
16 VCMP_IN	Enable the function during speed matching status (speed deviation < VCMP).
17 VCMP_OUT	Enable the function while speed matching status is not kept.

Low speed status [LOWV_IN]: Function is enabled during low speed status (speed below LOWV set value).

Low speed status [LOWV_OUT]: Function is enabled outside of low speed status (speed below LOWV set value).

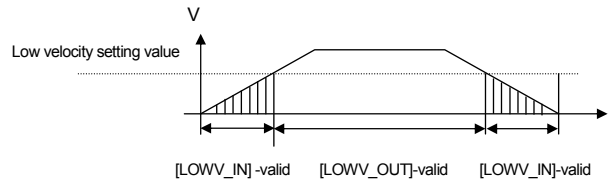

Speed coincidence status [VCMP_IN]: Function is enabled during speed coincidence status (speed deviation below VCMP set value).

Speed coincidence status [VCMP_OUT]: Function is enabled outside of speed coincidence status (speed deviation below VCMP set value).

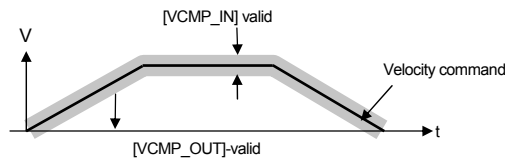

Speed transport status [VA_IN]: Function is enabled during speed transport status (speed above VA set value).

Speed transport status [VA_OUT]: Function is enabled outside of speed transport status (speed above VA set value).

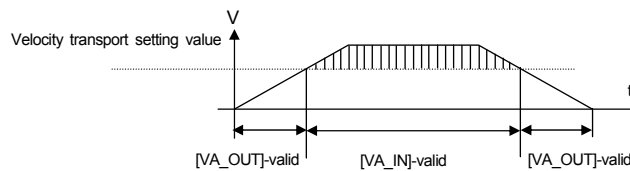

7.Adjustment·Functions

■ Functions of Group 9

[Group 9] 00 to 01

Forward Over-Travel Function [F-OT]

Reverse Over-Travel Function [R-OT] Position control mode Velocity control mode Torque control mode

The over travel function uses a limit switch to prevent damage to the unit. It stops the unit when the movement range of the moving part is exceeded.

1. Allocate the over travel input signal to CONT1 to CONT8.

Parameter Group9 Page00	F-OT: Positive Over-Travel Function
Parameter Group9 Page02	R-OT: Negative Over-Travel Function

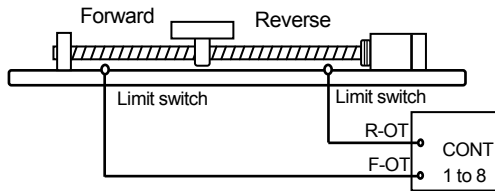

2. If the over travel function is used, select the operating conditions of “Position command input, Servo motor stop operation and Servo ON signal” in the case of over travel.

Parameter GroupB Page11	ACTOT: Over-Travel Action Selection
-------------------------	-------------------------------------

Selected value	Contents
00:_CMDINH_SB_SON	PC is inhibited and Servo-Braking is performed. After stops, S-ON is operated. (At OT, command disabled = velocity limit command = 0)
01:_CMDINH_DB_SON	PC is inhibited and Dynamic-Braking is performed. After stops, S-ON is operated. (At OT, command disabled = velocity limit command = 0)
02:_CMDINH_Free_SON	PC is inhibited and Free-Run is performed. After stops, Servo-ON is operated. (At OT, command disabled = velocity limit command = 0)
03:_CMDINH_SB_SOFF	PC is inhibited and Servo-Braking is performed. After stops, S-OFF is operated.
04:_CMDINH_DB_SOFF	PC is inhibited and Dynamic-Braking is performed. After stops, S-OFF is operated.
05:_CMDINH_Free_SOFF	PC is inhibited and Free-Run is performed. After stops, Servo-OFF is operated.
06:_CMDACK_VCLM=0	Position Command is accepted and Velocity Limit is zero.

If “the motor is stopped by servo brake operation” [00:_CMDINH_SB_SON][03:_CMDINH_SB_SOFF] is selected when over travel occurs, torque at the time of servo brake operation can be set at the sequence torque operation limit value.

Parameter Group8 Page37	SQTCLM: Torque Limit at Sequence Operation	10 to 500%
-------------------------	--	------------

If the value higher than the maximum output torque (TP) of the servo motor is set, it will be limited by (TP).

7.Adjustment·Functions

[Functions of Group 9][Alarm reset·Servo ON]

[Group 9] 02

Alarm Reset Function [AL-RST] Position control mode Velocity control mode Torque control mode

This function enables the sending of an alarm reset signal from the host unit. An alarm is cleared by enabling alarm reset function (AL-RST).

The conditions for enabling alarm reset function are assigned. The alarm is cleared if the AL-RST signal is valid.

Parameter Group9 Page02 | AL-RST: Alarm Reset Function

The following circuit is created when valid conditions are assigned to CONT2. The logic can also be modified by the allocation of valid conditions.

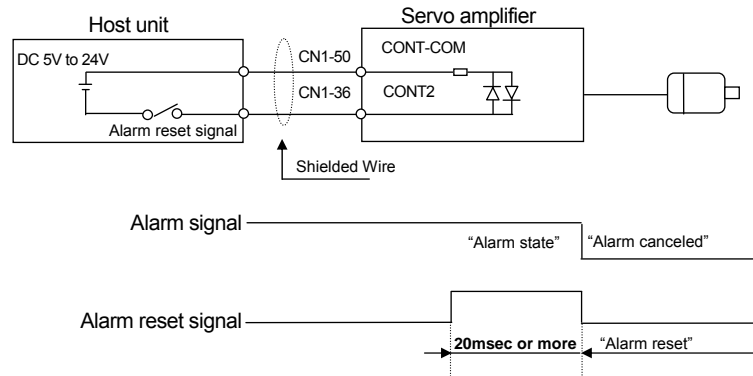

* Note that any alarm not cleared by simply turning OFF the control power supply cannot be cleared with the alarm reset signal.

[Group 9] 05

SERVO-ON Function [S-ON] Position control mode Velocity control mode Torque control mode

This function enables the sending of a servo ON signal from the host unit. The servo motor can be set to "ready" status by enabling the servo ON function (SON).

The conditions for enabling the Servo ON function are assigned. The servo motor is set to "ready" status when the SON signal is enabled.

Parameter Group9 Page05 | S-ON: SERVO-ON Function

The following circuit is created when valid conditions are assigned to CONT1. The logic can also be modified by the allocation of valid conditions.

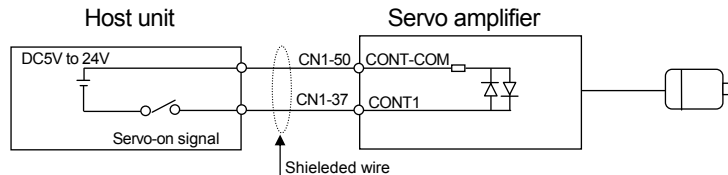

7.Adjustment·Functions

[Functions of Group 9][Control mode switch over·Position command pulse inhibit/Zero velocity stop]

[Group 9] 10

Control Mode Switching Function [MS] Position control mode Velocity control mode Torque control mode

2 types of control mode can be switched and used. The control mode to be combined is selected by system parameter and can be switched with control mode switch over function.

Control mode is selected from system parameter Page 08.

Page	Name	Setting range
08	Control Mode	6 ways

Setting	Contents
03: Velo-Torq	Velocity Control Mode-torque control switching type
04: Posi-Torq	Position Control Mode-torque control switching type
05: Posi-Velo	Position control-velocity control switching type

After setting has been changed → The value becomes valid when control power is turned ON again.

Conditions enabling control mode switch over function are allocated. When MS signal is valid, control mode is switched.

Parameter Group9 Page10	MS: Control Mode Switching Function
-------------------------	-------------------------------------

 When control mode switch over type is in use, there is a possibility that "auto-notch frequency tuning", "auto-vibration suppressing frequency tuning", and "JOG operation" cannot be used. Please use "Auto-notch frequency tuning," "Auto-vibration suppression frequency tuning," and "JOG-operation" after changing control mode to primary side (turning off the switch).

[Group 9] 11

Position Command Pulse Inhibit Function and Velocity Command Zero Clamp Function [INH/Z-STP]

Velocity control mode Position control mode

This can be used as position command pulse inhibit function (INHIBIT function) in the position control type, and as zero velocity stop function in the velocity control type.

When the function is enabled while servo motor is operating, input command is inhibited and the servo motor stops at servo motor excitation status. In the position control type, even if position command pulse is input, the input pulse is not counted in the servo amplifier.

Conditions enabling position command pulse inhibit/zero velocity stop function are allocated. When signals of INH/Z-STP are valid, this will function.

Parameter Group9 Page11	INH/Z-STP: Position Command Pulse Inhibit Function/ Velocity Command Zero Clamp Function
-------------------------	--

7.Adjustment·Functions

[Functions of Group 9][Gain switch over]

[Group9] 13,14

Gain Switching Function, Select Input 1 [GC1]
Gain Switching Function, Select Input 2 [GC2]

Position control mode Velocity control mode Torque control mode

4 types of gains can be switched and used.

Conditions enabling gain switch over are allocated. You can switch GAIN 1 to 4 by combination of GC1 and GC2 setting.

Parameter Group9 Page13	GC1: Gain Switching Function, Select Input 1
Parameter Group9 Page14	GC2: Gain Switching Function, Select Input 2

GC1: Gain Switching Function, Select Input 1	Disabled	Enabled	Disabled	Enabled
GC2: Gain Switching Function, Select Input 2	Disabled	Disabled	Enabled	Enabled
	↓	↓	↓	↓
Gain to be enabled	GAIN 1	GAIN 2	GAIN 3	GAIN 4

[Group 9] 15,16

Position control mode Velocity control mode Torque control mode

Vibration Suppressor Frequency, Select Input 1 [SUPFSEL1]
Vibration Suppressor Frequency, Select Input 2 [SUPFSEL2]

4 types of vibration suppressing frequency can be switched and used.

Conditions for enabling vibration suppressing frequency selection input are allocated. You can switch FF vibration suppression frequency 1 to 4 by combination of SUPFSEL1 and SUPFSEL2 setting.

Parameter Group9 Page15	SUPFSEL1: Vibration Suppressor Frequency, Select Input 1
Parameter Group9 Page16	SUPFSEL2: Vibration Suppressor Frequency, Select Input 2

SUPFSEL1: Vibration Suppressor Frequency, Select Input 1	Disabled	Enabled	Disabled	Enabled
SUPFSEL2: Vibration Suppressor Frequency, Select Input 2	Disabled	Disabled	Enabled	Enabled
	↓	↓	↓	↓
Vibration suppressing frequency to be enabled	Vibration Suppressor Frequency 1 Group2 Page 00	Vibration Suppressor Frequency 2 Group 3 Page 40	Vibration Suppressor Frequency 3 Group 3 Page 41	Vibration Suppressor Frequency 4 Group 3 Page 42

7.Adjustment·Functions

[Functions of group 9][Position·velocity loop proportional control switch over]

[Group 9] 17

Position Loop Proportional Control, Switching Function [PLPCON]

Position control mode

Switching between position loop PI control $\leftarrow \rightarrow$ P control is possible. Switching is possible when position loop proportional control switchover function (PLPCON) is enabled.

Conditions for enabling position loop proportional control switchover function are allocated. Switches to proportional control when the signal of PLPCON is valid.

Parameter Group9 Page17 | PLPCON: Position Loop Proportional Control, Switching Function

PI control(proportional·integral control)···Position loop proportional gain (KP)·Integral time constant (TPI)
P control (Proportional control)···Position loop proportional gain (KP)

* Position loop integral time constant (TPI) is 1000.0ms at standard setting, therefore, integral function is invalid.

[Group 9] 26

Velocity Loop Proportional Control, Switching Function [VLPCON]

Velocity control mode Position control mode

Velocity loop PI control / P control can be used alternatively. Activate switching by enabling the velocity loop comparison control switching function (VLPCON)

The conditions for enabling the velocity loop comparison control switching function are assigned. Change the comparison control when the VLPCON signal is valid.

Parameter Group9 Page26 | VLPCON: Velocity Loop Proportional Control, Switching Function

PI control (comparison / integral control): Velocity loop comparison gain (KVP) / Velocity loop reset time constant (TVI)
P control (Comparison control): Velocity loop comparison gain (KVP)

* When set to comparison control, servo gain is reduced and the servo system is made stable.

* When the velocity loop reset time constant (TVI) is set to 1000.0ms, it is not necessary to use this function, since the reset time constant in use is invalid (Comparison control)

7.Adjustment·Functions

[Functions of Group 9][External trip·Forced discharge·Emergency stop]

[Group 9] 40

External Error Input [EXT-E] Position control mode Velocity control mode Torque control mode

This function can output a contact input (such as external thermal) as an alarm (AL55) in the servo amplifier.

The conditions for enabling the external trip function are assigned. An alarm (AL55) is given if the EXT-E signal is valid.

Parameter Group9 Page40 EXT-E: External Error Input

[Group 9] 41

Main Power Discharge Function [DISCHARG]

Position control mode Velocity control mode Torque control mode

This function forcefully discharges voltage charged in the condenser for the main circuit power supply in the servo amplifier when power supply to the main circuit is cut. However, discharge is not possible when the main circuit power supply is ON.

The conditions for enabling forced discharge function are assigned. Forced discharge is possible when the DISCHARGE signal is valid.

Parameter Group9 Page41 DISCHARGE: Main Power Discharge Function

[Group 9] 42

Emergency Stop Function [EMR] Position control mode Velocity control mode Torque control mode

This function enables an emergency stop of the servo motor after receiving an emergency stop signal in the servo amplifier.

The conditions for enabling the unit emergency stop signal are assigned. The unit emergency stop function is executed when the EMR signal is valid.

Parameter Group9 Page42 EMR: Emergency Stop Function

7.Adjustment·Functions

[Functions of Group B][Dynamic brake·Forced stop]

■ Functions of Group B

[GroupB] 10

Dynamic Brake Action Selection [DBOPE]

Position control mode Velocity control mode Torque control mode

Conditions for stop at servo OFF can be selected from Servo brake/dynamic brake/free run.

Conditions after servo motor stop can be selected from dynamic brake/free run.

Parameter GroupB Page10 | DBOPE: Dynamic Brake Action Selection

Selected value	
00:_Free_Free	When Servo-OFF, Free-Run is operated. After stops, Motor-Free is operated.
01:_Free_DB	When Servo-OFF, Free-Run is operated. After stops, Dynamic-Braking is performed.
02:_DB_Free	When S-OFF, Dynamic-Braking is performed. After stops, Motor-Free is operated.
03:_DB_DB	When S-OFF, Dynamic-Braking is performed. After stops, Dynamic-Braking.
04:_SB_Free	When Servo-OFF, Servo-Braking is performed. After stops, Motor-Free is operated.
05:_SB_DB	When Servo-OFF, Servo-Braking is performed. After stops, Dynamic-Braking.

[GroupB] 12

Forced stop operation [ACTEMR]

Position control mode Velocity control mode

When forced stop is executed by power shut off while servo motor is operating (servo motor is not stopped), conditions for servo motor stop can be selected from servo brake/dynamic brake.

Parameter GroupB Page12 | ACTEMR: Emergency Stop Operation

Selected value	Contents
00:_SERVO-BRAKE	When EMR is input, motor is stopped by servo brake operation.
01:_DINAMIC-BRAKE	When EMR is input, motor is stopped by dynamic brake operation.

7.Adjustment·Functions

[Functions of Group B][Holding brake operation delay time]

[GroupB] 13

Delay Time of Engaging Holding Brake [BONDLY]

Position control mode Velocity control mode Torque control mode

This function is enabled during servo brake operation at servo OFF. It is disabled for dynamic brake and free-run.

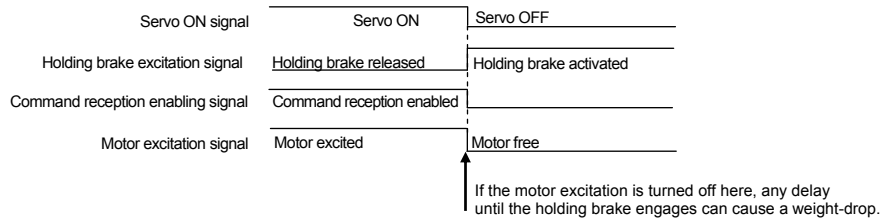

Set the delay time for the holding brake operation

Parameter GroupB Page13	BONDLY: Delay Time of Engaging Holding Brake	0 to 1000ms
-------------------------	--	-------------

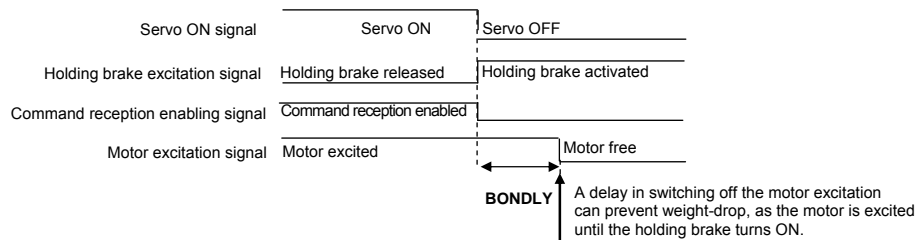

* The setting increment is 4 msec. If the setting is 0 msec, the command is disabled (forced zero) for 4 msec after SON.

The holding brake excitation signal can be output through the general outputs (OUT1 to OUT8).

Parameter GroupA Page0 *	OUT*: General Purpose Output*
--------------------------	-------------------------------

0A: _MBR-ON_ON	The output is ON while holding brake excitation signal outputs.
0B: _MBR-ON_OFF	The output is OFF while holding brake excitation signal outputs.

7.Adjustment·Functions

[Functions of Group B][Holding brake release delay time]

[GroupB] 14

Delay Time of Releasing Holding Brake [BOFFDLY]

Position control mode Velocity control mode Torque control mode

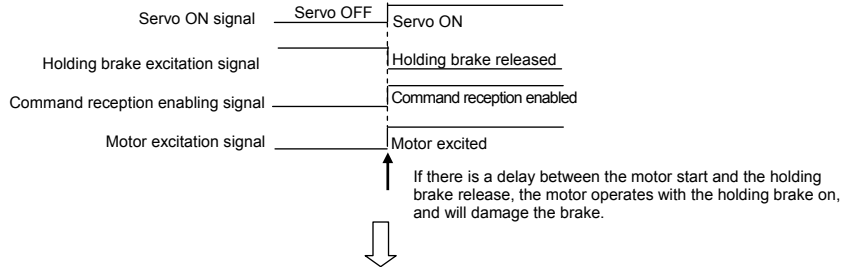

Set the delay time for the holding brake release

Parameter GroupB Page14	BOFFDLY: Delay Time of Releasing Holding Brake	0 to 1000ms
-------------------------	--	-------------

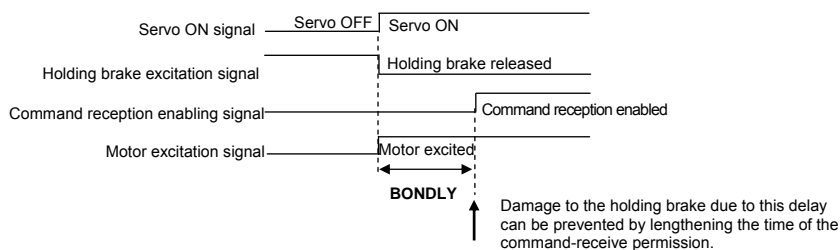

- * The setting increment is 4 msec. If the setting is 0 msec, the command is disabled (forced zero) for 4 msec after SON.

The holding brake excitation signal can be output through the general outputs (OUT1 to OUT8).

Parameter Group9 Page0 *	OUT*: General Purpose Output *
--------------------------	--------------------------------

0A: _MBR-ON_ON	The output is ON while holding brake excitation signal outputs.
0B: _MBR-ON_OFF	The output is OFF while holding brake excitation signal outputs.

[GroupB] 15

Brake Operation Beginning Time [BONBGN]

Position control mode Velocity control mode Torque control mode

If the motor does not stop within the time frame set for the brake operation start (BONBGN) when the servo is turned OFF, the holding brake and the dynamic brake force the motor to stop. The function can be disabled by setting the value to "0"ms. The setting increment is 4msec; therefore, set the value to 4 msec or higher.

Parameter GroupB Page15	BONBGN: Brake Operation Beginning Time	0 to 65535ms
-------------------------	--	--------------

- * The term "motor does not stop" (above) means that the motor velocity does not fall below the zero velocity (ZV) range.
- * The stop sequence is different depending on the condition settings of the emergency stop operation.
- * When the brake operation start time (BONBGN) passes, the servo motor will be forced to stop by both the dynamic brake and the holding brake, which can cause damage to the holding brake. Therefore, use this function only after considering the specifications and the sequence of the unit.

7.Adjustment·Functions

[Functions of Group B][Power failure detection delay time]

[GroupB] 16

Power Failure Detection Delay Time [PFDDLY]

Position control mode Velocity control mode Torque control mode

This function can set a delay period, after power off of the control power supply, for detecting problems in the control power supply. Detection of unexpected power failure is diminished when this value is increased. However, even if this value is increased and problem detection is delayed, when the power supply to the internal logic circuit is exhausted, routine operations at the time of control power supply cut off/ restart will continue.

Parameter GroupB Page16	PFDDLY: Power Failure Detection Delay Time	20 to 1000 ms
-------------------------	--	---------------

- * When energy to the main circuit power supply is insufficient, problems like a reduction in main circuit power supply are also detected.
- * The actual anomaly detection delay time compared to the selected value can vary between -12ms and +6ms.

7.Adjustment·Functions

[Functions of Group B][Excessive deviation warning·Deviation counter overflow·Overload warning]

[GroupB] 20

Following Error Warning Level [OFWLVL]

Position control mode Velocity control mode Torque control mode

This function gives a warning before reaching excessive deviation alarm status.

Set the deviation excessive warning value.

Parameter GroupB Page20	OFWLVL: Following Error Warning Level	1 to 65535x1024 pulse
-------------------------	---------------------------------------	-----------------------

For sending the signals to the host unit, assign the signals in parameter Group 9. Output from general output number (OUT1 to OUT8) of the connected CNs1.

Parameter GroupA Page0 *	OUT*: General Purpose Output *
--------------------------	--------------------------------

2A: WNG-OFW_ON	The output is ON during following warning status (position deviation > OFWLVL).
2B: WNG-OFW_OFF	The output is OFF during following warning status (position deviation > OFWLVL).

[GroupB] 21

Following Error Limit [OFLVL]

Position control mode Velocity control mode Torque control mode

Parameter to set the value for outputting excessive position deviation alarm. Encoder pulse is the standard irrespective of electronic gear or command multiplication functions.

Deviation counter overflow value is set.

Parameter GroupB Page21	OFLVL: Following Error Limit	1 to 65535x1024 pulse
-------------------------	------------------------------	-----------------------

[GroupB] 22

Overload Warning Level [OLWLVL]

Position control mode Velocity control mode Torque control mode

This function will send a warning before reaching overload alarm status. Set the ratio corresponding to the overload alarm value to 100%. When set to 100%, the overload warning and overload alarm are given simultaneously.

Set the overload warning level.

Parameter GroupB Page22	OLWLVL: Overload Warning Level	20 to 100 %
-------------------------	--------------------------------	-------------

For sending the signals to the host unit, assign the signals in parameter Group 9. Output from general output terminal (OUT1 to OUT8) of the connected CN1.

Parameter GroupA Page0 *	OUT*: General Purpose Output *
--------------------------	--------------------------------

2C: WNG-OLW_ON	The output is ON during over-load warning status.
2D: WNG-OLW_OFF	The output is OFF during over-load warning status.

* The overload detection process is assumed to be 75% of the rated load at the time of starting the control power supply (hot start). At this time, if the overload warning level is set below 75%, an overload warning is given after starting the control power supply.

7.Adjustment·Functions

[Functions of Group C][Digital filter·External encoder polarity]

■ Functions of Group C

[GroupC] 01 to 02

Position control mode Velocity control mode Torque control mode

Motor Incremental Encoder, Digital Filter [ENFIL] External Incremental Encoder, Digital Filter [EX-ENFIL] **Fully-closed control**

You can set the digital filter value of the incremental pulse for the selected incremental encoder. When noise is superimposed on the incremental encoder, the pulse below the set value is removed as noise. Set this value by considering the frequency of pulses from the selected encoder and the maximum number of rotations of the servo motor. If the input value is greater than the encoder frequency during the peak rotation of the servo motor, the encoder pulse is removed and the servo motor will stop.

The motor encoder and external encoder can be set separately.

Selection for motor incremental encoder digital filter

Parameter GroupC Page01	ENFIL: Motor Incremental Encoder, Digital Filter
Parameter GroupC Page02	EX-ENFIL: External Incremental Encoder, Digital Filter

Selected value	Contents
00: _110nsec	Minimum Pulse Width=110nsec (Minimum Pulse Phase Difference=37.5nsec)
01: _220nsec	Minimum Pulse Width=220nsec
02: _440nsec	Minimum Pulse Width=440nsec
03: _880nsec	Minimum Pulse Width=880nsec
04: _75nsec	Minimum Pulse Width=75nsec (Minimum Pulse Phase Difference = 37.5nsec)
05: _150nsec	Minimum Pulse Width=150nsec
06: _300nsec	Minimum Pulse Width=300nsec
07: _600nsec	Minimum Pulse Width=600nsec

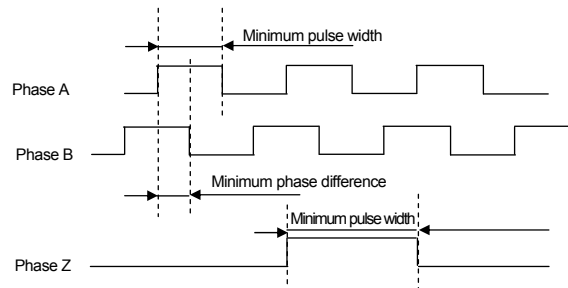

[GroupC] 03

External Encoder Polarity Invert [EX-ENPOL]

Position control mode Velocity control mode Torque control mode

You can select external encoder pulse polarity.

Parameter GroupC Page03	EX-ENPOL: External Encoder Polarity Invert
-------------------------	--

Fully-closed control

Selected value	Contents		
00: Type1	EX-Z / Not Reversed	EX-B / Not Reversed	EX-A / Not Reversed
01: Type2	EX-Z / Not Reversed	EX-B / Not Reversed	EX-A / Reversed
02: Type3	EX-Z / Not Reversed	EX-B/Reversed	EX-A / Not Reversed
03: Type4	EX-Z / Not Reversed	EX-B/Reversed	EX-A / Reversed
04: Type5	EX-Z / Reversed	EX-B / Not Reversed	EX-A / Not Reversed
05: Type6	EX-Z / Reversed	EX-B / Not Reversed	EX-A / Reversed
06: Type7	EX-Z / Reversed	EX-B / Reversed	EX-A / Not Reversed
07: Type8	EX-Z / Reversed	EX-B / Reversed	EX-A / Reversed

This setting is disabled in case of full closed control and when motor encoder is absolute encoder.
(To be set at Type 1.)

7.Adjustment·Functions

[Functions of Group C][Encoder pulse division]

[GroupC] 04

Encoder Pulse Divided Output, Selection [PULOUTSEL]

Position control mode Velocity control mode Torque control mode

Encoder pulse divider output can be selected from 2 types; motor encoder or external encoder.

Parameter GroupC Page04 PULOUTSEL: Encoder Pulse Divided Output, Selection

Selected value	Contents
00: Motor Enc.	Motor Encoder
01: External Enc.	External Encoder

Fully-closed control

- For semi-closed control, select 00:Motor encoder.
- With semi-closed control, if the motor encoder is an absolute encoder other than the absolute encoder with incremental output, incremental pulse of 8192P/R will be input into the division circuit.
- When full-closed controlled and motor encoder is absolute encoder, external encoder pulse is output by selecting any.

[GroupC] 05

Encoder Output Pulse, Divide Ratio [ENRAT]

Position control mode Velocity control mode Torque control mode

The encoder signals (Phase A/ Phase B) used in the host unit can be output according to a ratio formula. When using in the host unit's position loop control, input the result (obtained after dividing the number of encoder pulses) as an integer. However, when using this function to monitor the host unit, input a ratio that is as close to the setup value as possible.

The output of Z phase is not divided. Output can be sin Open Collector (CN1-11).

Division ratio for the encoder pulse divider output is set.

Parameter GroupC Page05 ENRAT: Encoder Output Pulse, Divide Ratio 1/1 to 1/8192

The following settings are possible.

When numerator is "1" : $1/1$ to $1/64$, $1/8192$ can be set.

When numerator is "2" : $2/3$ to $2/64$, $2/8192$ can be set.

When denominator is "8192" : $1/8192$ to $8191/8192$ can be set.

Frequency division 1/1 (Forward rotation)

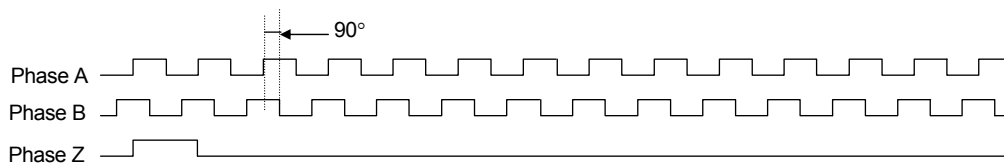

Frequency division 1/2 (Forward rotation)

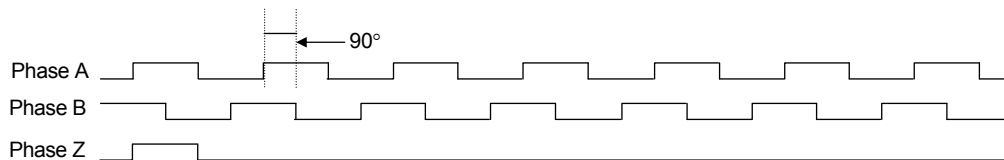

Frequency division 2/5 (Forward rotation)

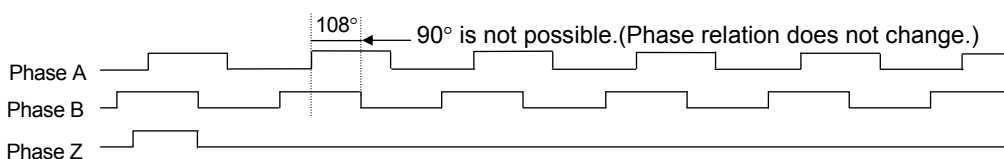

* Destabilizes for 1 sec after control power is supplied.

7.Adjustment·Functions

[Functions of Group C][Encoder division·Encoder clear]

[GroupC] 06

Encoder Pulse Divided output, Polarity [PULOUTPOL]

Position control mode Velocity control mode Torque control mode

The polarity of the encoder pulse frequency output can be selected.

Parameter GroupC Page06 PULOUTPOL: Encoder Pulse Divided output, Polarity

Selected value	Contents
00:_Type1	A-Phase Signal/ Not Reversed: Z-Phase Signal Logic / High Active
01:_Type2	A-Phase Signal/ Reversed: Z-Phase Signal Logic / High Active
02:_Type3	A-Phase Signal/ Not Reversed: Z-Phase Signal Logic / Low Active
03:_Type4	A-Phase Signal/ Reversed: Z-Phase Signal Logic / Low Active

Setting 00H (Frequency division ratio 1/1: with forward rotation)
When using the incremental encoder

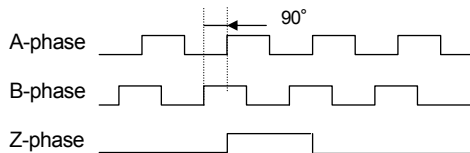

Setting 03H (Frequency division ratio 1/1: with forward rotation)
When using the incremental encoder

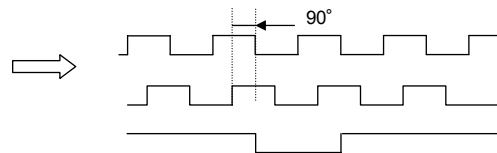

[GroupC] 08

Abusolute Encoder Clear Function Selection [ECLRFUNC]

Position control mode Velocity control mode Torque control mode

Select the conditions for enabling absolute encoder clear.

Parameter Group9 Page03 ECLR: Abusolute Encoder Clear Function

When using a battery backup method absolute encoder and absolute encoder without battery, you can select the contents to be cleared.

Clear "Warning + multiple rotation data"

Clear only "Warning"

Parameter GroupC Page08 ECLRFUNC: Abusolute Encoder Clear Function Selection

Selected value	Contents
00:_Status_MultiTurn	Clear Encoder Status (Alarm and Warning) and Multi Turn Data
01:_Status	Clear Only Encoder Status

* These conditions are applicable only to the battery backup method absolute encoder and absolute encoder without battery.

* Do not input this while the servo motor is rotating. Confirm that the servo motor stops before inputting this.

7.Adjustment·Functions

[Monitor][Analog monitor]

■ Description of monitor

All signals and internal status of the servo amplifier can be monitored. There are 3 kinds of monitors.

1. Analog monitor
2. Digital monitor
3. Monitor in display (setup software *R-SETUP, Digital Operator*)

Monitor box and dedicated monitor cable are needed. Refer to “Materials; Option, Monitor box.”
 Refer to “Chapter 1, Prior to Use, Servo Amplifier Part Names 1-8” for locations for connectors to be connected.

● Analog monitor (2 channels)

[Group A] 11 to 13

Position control mode Velocity control mode Torque control mode

Analog Monitor 1, Output Signal Selection [MON1]

Analog Monitor 2, Output Signal Selection [MON2]

Analog Monitor, Output Polarity [MONPOL]

Analog monitor for use is selected.

Parameter GroupA Page11	MON1: Analog Monitor 1, Output Signal Selection
Parameter GroupA Page12	MON2: Analog Monitor 2, Output Signal Selection

Selected value	Contents
00	Reserved
01: TMON 2V/TR	Torque Monitor 2V/ rated torque (thrust)
02: TCMON 2V/TR	Torque Command Monitor 2V/ rated torque (thrust)
03: VMON 0.2mV/ min ⁻¹	Velocity Monitor 0.2mV/ min ⁻¹
04: VMON 1mV/ min ⁻¹	Velocity Monitor 1mV/ min ⁻¹
05: VMON 2mV/ min ⁻¹	Velocity Monitor 2mV/ min ⁻¹
06: VMON 3mV/ min ⁻¹	Velocity Monitor 3mV/ min ⁻¹
07: VCMON 0.2mV/ min ⁻¹	Velocity Command Monitor 0.2mV/ min ⁻¹
08: VCMON 1mV/ min ⁻¹	Velocity Command Monitor 1mV/ min ⁻¹
09: VCMON 2mV/ min ⁻¹	Velocity Command Monitor 2mV/ min ⁻¹
0A: VCMON 3mV/ min ⁻¹	Velocity Command Monitor 3mV/ min ⁻¹
0B: PMON 0.1mV/P	Position Deviation Monitor 0.1mV/ Pulse
0C: PMON 1mV/P	Position Deviation Monitor 1mV/ Pulse
0D: PMON 10mV/P	Position Deviation Monitor 10mV/ Pulse
0E: PMON 20mV/P	Position Deviation Monitor 20mV/ Pulse
0F: PMON 50mV/P	Position Deviation Monitor 50mV/ Pulse
10: FMON 2mV/kP/s	Position Command Pulse Input Frequency Monitor 2mV/kPulse/s
11: FMON 10mV/kP/s	Position Command Pulse Input Frequency Monitor 10mV/kPulse/s
12: TLMON EST 2V/TR	Load Torque Monitor (Estimate Value) 2V/ rated torque (thrust)
13: Sine-U	Sine-U
14: VBUS 1V/DC100V	Main Power Circuit D.C. Voltage 1V/DC100V
15: VBUS 1V/DC10V	Main Power Circuit D.C. Voltage 1V/DC10V

Select this when polarity is to be changed.

Parameter GroupA Page13	MONPOL: Analog Monitor, Output Polarity
-------------------------	---

Selected value	Contents
00:_MON1+_MON2+	MON1: Positive voltage output in forward rotation; output pos and neg voltage. MON2: Positive voltage output in forward rotation; output pos and neg voltage.
01:_MON1-_MON2+	MON1: Negative voltage output in forward rotation; output pos and neg voltage. MON2: Positive voltage output in forward rotation; output pos and neg voltage.
02:_MON1+_MON2-	MON1: Positive voltage output in forward rotation; output pos and neg voltage. MON2: Negative voltage output in forward rotation; output pos and neg voltage.
03:_MON1-_MON2-	MON1: Negative voltage output in forward rotation; output pos and neg voltage. MON2: Negative voltage output in forward rotation; output pos and neg voltage.
04:_MON1ABS_MON2+	MON1: Positive voltage output together in forward and reverse rotation MON2: Positive voltage output in forward rotation; output pos and neg voltage.
05:_MON1ABS_MON2-	MON1: Positive voltage output together in forward and reverse rotation MON2: Negative voltage output in forward rotation; output pos and neg voltage.
06:_MON1+_MON2ABS	MON1: Positive voltage output in forward rotation; output pos and neg voltage. MON2: Positive voltage output together in forward and reverse rotation
07:_MON1-_MON2ABS	MON1: Negative voltage output in forward rotation; output pos and neg voltage. MON2: Positive voltage output together in forward and reverse rotation
08:_MON1ABS_MON2ABS	MON1: Positive voltage output together in forward and reverse rotation MON2: Positive voltage output together in forward and reverse rotation

7.Adjustment·Functions [Monitor][Digital monitor][Displayed monitor list]

● Digital monitor (1 channel)

[Group A] 10

Digital Monitor 1, Output Signal Selection [DMON]

Position control mode Velocity control mode Torque control mode

Digital monitor for use is selected.

Parameter GroupA Page10 DMON: Digital Monitor 1, Output Signal Selection

For selected values, refer to “Chapter 5, Parameter [Parameter setting value [GroupA]] general output OUT1 to general output OUT8, and setting selection list of digital monitor output.

● List of monitors in display

[Monitor] 00 to 1E

Page	Name	Contents	Unit
00	Servo Amplifier Status	Displays the statuses of main circuit power being supplied, operation ready and servo ON.	---
01	Warning status 1	Displays warning status.	---
02	Warning status 2	Displays warning status.	---
03	General Purpose Input CONT8 to CONT1 Monitor	Displays general input terminal status.	---
04	General Purpose Output OUT8 to OUT1 Monitor	Displays general output terminal status.	---
05	Velocity Monitor	Displays motor rotation velocity.	min ⁻¹
06	Velocity Command Monitor	Displays velocity command value.	min ⁻¹
07	Torque Monitor	Displays motor output torque.	%
08	Torque Command Monitor	Displays torque command value.	%
09	Position Deviation Monitor	Displays position deviation values.	Pulse
0A	Actual Position Monitor	Displays current position compared with original position when the control power is turned ON. This is a free run counter. Therefore, when current position exceeds the displayed range, the display is maximum value of reversed polarity.	Pulse
0B	External Actual Position Monitor		
0C	Command Position Monitor		
0D	Analog Velocity Command/Analog Torque Command Input Voltage	Displays command voltage being input.	mV
0E	Position Command Pulse Input Frequency Monitor	Displays command pulse frequency being input.	k Pulse/s
0F	U-Phase Electric Angle Monitor	Displays electric angle of phase U. Except for encoder error, this is always displayed.	deg
10	Absolute Encoder PS Data (High)	Displays absolute encoder position data PS.	x2 ³² P
11	Absolute Encoder PS Data (Low)	Displays absolute encoder position data PS.	Pulse
12	Regenerative Resistor Operation Percentage	Displays regeneration resistance operation status.	%
13	Motor Operating Rate Monitor	Displays exact values, however, it may take several hours for the value to become stable depending on the operation pattern.	%
14	Predicted Motor Operating Rate Monitor	Displays estimated value of servo motor usage ratio, which is estimated from a short period of operation. In an application where the same operation pattern repeats in a short period of time, the usage ratio can be confirmed fast.	%
15	Load Inertia (Mass) Ratio Monitor	Values can be confirmed when gain switch over and auto-tuning functions are used.	%
16	Position Loop Proportional Gain Monitor		1/s
17	Position Loop Integral Time Constant Monitor	Values can be confirmed when gain switch over function is used.	ms
18	Velocity Loop Proportional Gain Monitor	Values can be confirmed when gain switch over and auto-tuning function are used.	Hz
19	Velocity Loop Integral Time Constant Monitor		ms
1A	Torque Command Filter Monitor		Hz
1B	Incremental Encoder Signal Monitor	Incremental signal of CN2 is displayed.	---
1C	Load Torque Monitor (estimated Value)	Load torque is displayed.	%
1D	Powre Monitor	Main circuit DC voltage is displayed.	V
1E	Servo Amplifier Operation Time	Counted while control power supply is ON. The time is displayed value x 2hours.	x 2hour

For displays of monitor by digital operator, refer to “Chapter 4, Digital operator.”

For displays of monitor by Setup Software, refer to “Setup Software R-SETUP.”

No Text on This Page.

[Maintenance]

◆	Trouble Shooting.....	8-1
◆	Alarm List	8-3
◆	Trouble shooting when Alarm Occurs.....	8-5
◆	Inspection / Parts Overhaul.....	8-25

■ Corrective Actions for Problems During Operation

- When troubles occur without any alarm displayed, check and take corrective actions for them referring to the description below. When alarm occurs, perform corrective measures referring to “Trouble Shooting When Alarm Occurs”.



When you do the work for correction processing, be sure to intercept power supply.

No	Problems	Investigation	Assumed causes and corrective actions
1	“≡” does not light up to 7-segment LED even if main power is ON.	Check the voltage at the power input terminal.	<ul style="list-style-type: none"> • If voltage is low, check the power supply. • If there is no voltage, check that wires and screws are fastened properly.
		Check if red “CHARGE” LED is lighting off.	<ul style="list-style-type: none"> • Internal power circuit of servo amplifier is defective. → Place the servo amplifier.
2	7-segment LED displays a rotating character “8” (Servo ON status), but motor does not rotate.	Check of command is input by the digital operator's monitor. page 06 : Velocity Command Monitor page 08 : Torque Command Monitor page 0E : Position Command Monitor The monitor's value is zero.	<ul style="list-style-type: none"> • Input a command.
		Servo is not locked.	<ul style="list-style-type: none"> • Confirm that power line of motor is connected.
		Check if torque limit is input.	<ul style="list-style-type: none"> • Because torque limit has been input, motor cannot rotate more than load torque.
		Enter deviation clear to check if process is continued.	<ul style="list-style-type: none"> • Stop the input of deviation clear.
3	Operation of the servomotor is unstable and velocity is lower than command.	Check if proportional control is entered.	<ul style="list-style-type: none"> • Stop the input of proportional control.
		Check if torque limit is input.	<ul style="list-style-type: none"> • Stop inputting torque limit.
4	Servo motor rotates only once, and stops.	Check motor power line.	<ul style="list-style-type: none"> • The motor power line is not connected.
		Check the setup of encoder resolution. The digital operator's system parameter page 05: Absolute Encoder Resolution Setting. page 03: Incremental Encoder Resolution Setting	<ul style="list-style-type: none"> • Change the settings and turn ON the power again.

8.Maintenance

[Trouble shooting]

No	Problems	Investigation	Assumed causes and corrective actions
5	The servo motor runs recklessly.	Check the motor power line.	<ul style="list-style-type: none"> Phase order of motor power line does not match.
		Check the wiring of encoder cable.	<ul style="list-style-type: none"> Wiring of A phase and B phase of the encoder is incorrect.
6	Motor is vibrating with frequency above 200 Hz.	-	<ul style="list-style-type: none"> Reduce the loop gain speed. Set the torque command low-pass filter and torque command notch filter.
7	Overshoot and undershoot are generated during starting and stopping.	-	<ul style="list-style-type: none"> Adjust the servo tuning "response". Reduce the loop gain speed. Increase the integral time constant. Simplify the acceleration and deceleration command. Use position command low-pass filter.
8	Abnormal sound occurs	Check that there is no defect in mechanical installation.	<ul style="list-style-type: none"> Observe by operating one motor. Pay attention while coupling and confirm that there is no core shift or unbalance.
		Check whether abnormal sound is random or periodic while operating at low speed.	<ul style="list-style-type: none"> Confirm that the twisted pair and shield processing of encoder signal line are correct. Confirm that the wiring for encoder line and power line are installed in the same port. Confirm that the power supply voltage is sufficient.

Alarm list

Operation at detecting: "DB" performs the slowdown stop of the servo motor in dynamic brake operation when the alarm generating.

Operation at detecting: "SB" performs the slowdown stop of the servo motor with sequence current limiting value.

When dynamic brake is selected by forced stop operation selection, the servo motor is decelerating stopped for the dynamic brake operation regardless of the operation when detecting it.

(However, it stops in free servo brake operation at the time of alarm 53H (DB resistor overheating) detection).

	Alarm code								Alarm title	Alarm contents	Detection Operations	Alarm Clear
	Display	3 bits output			PY compatible code							
		Bit7	Bit6	Bit5	ALM3	ALM4	ALM2	ALM1				
Abnormality related to drive	21H	0	0	1	0	0	0	1	Power Module Error (Overcurrent)	<ul style="list-style-type: none"> Over current of drive module Abnormality in drive power source Overheating of drive module 	DB	V
	22H				0	0	0	1	Current Detection Error 0	<ul style="list-style-type: none"> Abnormality of electric current detection value 	DB	V
	23H				0	0	0	1	Current Detection Error 1	<ul style="list-style-type: none"> Abnormality of Electric current detection circuit 	DB	V
	24H				0	0	0	1	Current Detection Error 2	<ul style="list-style-type: none"> Abnormality in communication with electric current detection circuit 	DB	V
Abnormality related to load	41H	0	1	0	0	0	1	0	Overload 1	<ul style="list-style-type: none"> Excessive effective torque 	SB	V
	42H				0	0	1	0	Overload 2	<ul style="list-style-type: none"> Stall over load 	DB	V
	43H				0	1	0	1	Regenerative Error	<ul style="list-style-type: none"> Regeneration load ratio exorbitance 	DB	V
	51H				0	0	1	1	Amplifier Overheat	<ul style="list-style-type: none"> Overheating detection of amplifier ambient temperature 	SB	V
	52H				0	0	1	1	RS Overheat	<ul style="list-style-type: none"> Detection of in-rush prevention resistance overheating 	SB	V
	53H				0	0	1	1	Dynamic Brake Resistor Overheat	<ul style="list-style-type: none"> Overheating detection of DB resistor 	SB	V
	54H				0	1	0	1	Internal Overheat	<ul style="list-style-type: none"> Overheating detection of Internal regeneration resistor 	DB	V
	55H				0	0	1	1	External Error	<ul style="list-style-type: none"> Overheating detection of External regeneration resistor 	DB	V
	Alarm code								Alarm name	Alarm contents	Operations while detecting	Alarm clear
	Display	3 bits output			PY compatible code							
		Bit7	Bit6	Bit5	ALM3	ALM4	ALM2	ALM1				
Abnormality in power source	61H	0	1	1	0	1	0	1	Overvoltage	<ul style="list-style-type: none"> DC Excess voltage of main circuit 	DB	V
	62H				1	0	0	1	Main Circuit Undervoltage Note 1)	<ul style="list-style-type: none"> DC Main circuit low voltage 	DB	V
	63H				1	0	1	0	Main Power Supply Fail Phase Note 1)	<ul style="list-style-type: none"> Single-phase of the 3 phase main circuit power supply disconnected 	SB	V
	71H				0	1	1	1	Control Power Supply Undervoltage Note 3)	<ul style="list-style-type: none"> Control power supply low voltage 	DB	V Note 2)
	72H				0	1	1	1	Control Power Error	<ul style="list-style-type: none"> Under voltage of + 12 V 	SB	V
	Abnormality related to encoder wiring				81H	1	0	0	1	0	0	0
82H		1	0	0	0				Absolute Encoder Signal Disconnect	<ul style="list-style-type: none"> Absolute Encoder (PS) signal line break 	DB	V
83H		1	0	0	0				External Encoder Pulse Error (CN-EXT: A-Phase, B-Phase, Z-Phase)	<ul style="list-style-type: none"> Breaking of full close Encoder (A, B) signal line 	DB	V
84H		1	0	0	0				Communication Error Between Encoder and Amplifier	<ul style="list-style-type: none"> Encoder serial signal time out 	DB	V Note 4)
85H		1	0	0	0				Encoder Initial Process Error	<ul style="list-style-type: none"> Failed to read CS data of incremental encoder Abnormality in initial process of absolute encoder Cable break 	-	" "
87H		1	0	0	0				CS Signal Disconnection	<ul style="list-style-type: none"> CS signal line break 	DB	" "
91H		1	0	0	0				Encoder Command Error	<ul style="list-style-type: none"> Mismatch of transmission command and reception command 	DB	V
92H		1	0	0	0				Encoder FORM Error	<ul style="list-style-type: none"> Start, Stop bit Abnormality Insufficient data length 	DB	V
93H		1	0	0	0				Encoder SYNC Error	<ul style="list-style-type: none"> Data cannot be received during the prescribed time after the command is sent. 	DB	V
94H		1	0	0	0				Encoder CRC Error	<ul style="list-style-type: none"> CRC generated from the received data and sent CRC does not match 	DB	V

Note1: Control power error or servo ready OFF is detected during instantaneous break of 1.5 to 2 cycles.

Detection of control power error and servo ready OFF can be delayed by setting larger value of PFDDLY (Group B Page 16).

Note2: When the main power voltage increases or decreases gradually or is suspended, main circuit low voltage or main power failed phase may be detected.

Note3: When interruption of control power is long, it is regarded as power supply interception and re-input, and the detected error of control power is not left to an alarm history.

If interruption exceeds 1 second, it will be certainly judged as power supply interception.

Note4: When the absolute encoder with incremental output is used, alarm resetting is prohibited.

8.Maintenance

[Alarm list]

	Alarm code							Alarm name	Alarm contents	Operations While detecting	Alarm clear	
	Display	3 bits output			PY compatible code							
		Bit7	Bit6	Bit5	ALM 8	ALM 4	ALM 2					ALM 1
Abnormality in encoder main body	A1H	1	0	1	1	0	0	0	Encoder Error 1	• Breakdown of Encoder internal device	DB	Note 3)
	A2H				1	0	0	0	Absolute Encoder Battery Error	• Battery low voltage	DB	Note 3)
	A3H				1	0	0	0	Encoder Overheat	• Motor built-in Encoder Overheating	DB	Note 3)
	A5H				1	0	0	0	Encoder Error 3	• Error generation of multi-rotation data	DB	Note 3)
	A6H				1	0	0	0	Encoder Error 4	• Encoder internal EEPROM data is not set	DB	Note 3)
	A7H				1	0	0	0	Encoder Error 5	• Resolver abnormality	DB	Note 3)
	A8H				1	0	0	0	Encoder Error 6	• Resolver disconnection	DB	Note 3)
	A9H				1	0	0	0	Failure of Encoder	• Encoder failure	DB	Note 3)
	b2H				1	0	0	0	Encoder Error 2	• Position data incorrect	DB	Note 3)
	b3H				1	0	0	0	Absolute Encoder Multi-Turn Counter Error	• Detection of incorrect multiple rotations coefficient	DB	Note 3)
	b4H				1	0	0	0	Absolute Encoder Single-Turn Counter Error	• Detection of incorrect 1 rotation coefficient	DB	Note 3)
	b5H				1	0	0	0	Over-allowable Speed of Absolute Encoder at Turning ON	• Exceeds the permitted speed of motor rotation speed when the power is turned ON	DB	Note 3)
	b6H				1	0	0	0	Encoder Memory Error	• Access error of Encoder internal EEPROM	DB	Note 3)
b7H	1	0	0	0	Acceleration Error	• Exceeds the permitted speed for motor rotation	DB	Note 3)				
Control system abnormality	C1H	1	1	0	0	1	1	0	Overspeed	• Motor rotation speed is 120 % more than the highest speed limit	DB	V
	C2H				1	1	0	0	Speed Control Error	• Torque command and acceleration direction are not matching.	DB	V
	C3H				1	1	0	0	Speed Feedback Error	• Motor power disconnection (Note 2)	DB	V
	d1H				1	1	0	1	Following Error (Excessive Position Deviation)	• Position error exceeds setup value	DB	V
	d2H				1	1	0	1	Faulty Position Command Pulse Frequency 1	• Frequency of entered position command pulse is excessive	SB	V
	d3H				1	1	0	1	Faulty Position Command Pulse Frequency 2	• Position command frequency after electronic gear is high.	SB	V
	dFH				1	1	0	1	Test Run Close	• Detection in 'Test mode end' status	DB	V
Control system/Memory system abnormality	E1H	1	1	1	1	1	1	1	EEPROM Error	• Abnormality of amplifier with built-in EEPROM	DB	" "
	E2H				1	1	1	1	EEPROM Check Sum Error	• Error in check sum of EEPROM (entire area)	-	" "
	E3H				1	1	1	1	Internal RAM Error	• Access error in CPU built in RAM	-	" "
	E4H				1	1	1	1	Process Error between CPU and ASIC	• Access abnormality in CPU - ASIC	-	" "
	E5H				1	1	1	1	Parameter Error 1	• Detection when non-corresponding or undefined amplifier, motor, encoder code are specified.	-	" "
	E6H				1	1	1	1	Parameter Error 2	• Error in combining motor, encoder, and/or amplifier code set from system parameter	-	" "
	F1H				1	1	1	1	Task Process Error	• Error in interruption process of CPU	DB	" "
	F2H				1	1	1	1	Initial Process Time-Out	• Detection when initial process does not end within initial process time	-	" "

Note1: Alarm that rings in 'Test mode end' status is not recorded in the alarm history.

Note2: When there is a rapid motor slow down simultaneous with servo ON, there is a possibility that a break in the motor's power line cannot be detected.

Note3: Due to abnormality in encoder main body, encoder clear may sometimes be needed.

Note4: "V" means it is possible to reset. " " means it is not possible to reset.

Warning list

	Warning Title	Warning Contents
Load system	Overload Warning	• When the effective torque exceeds the set torque
	Regenerated Overload Warning	• In case of overload of regenerative resistance
	Amplifier Overheating Warning	• Ambient temperature of the amplifier is out of range of the set temperature
Power supply system	Main circuit is charging	• Voltage of main circuit is above DC 105 V
External input system	Forward over travel	• While entering forward over travel
	Reverse over travel	• While entering reverse over travel
Encoder system	Absolute encoder battery warning	• Battery voltage is below 3.0 V
Control system	Restricting torque command	• While restricting the torque command by torque restriction value
	Restricting speed command	• While restricting the speed command by speed value.
	Excessive position deviation	• When position deviation warning setup value is outside the proscribed limits

Note: Refer to Section 4-5 to 4-6 for the Warning Displays.

8.Maintenance

[Trouble shooting when alarm occurs]

Alarm code 21H (Power Module Error/ Overcurrent)



Status at the time of alarm	Cause			
	1	2	3	4
Issued when control power is turned ON.	(V)		V	(V)
Issued at servo input.	V	V	V	
Issued while starting and stopping the motor.	(V)	(V)	(V)	
Issued after extended operating time.	(V)	(V)	(V)	V

Corrective actions

Cause		Investigation and corrective actions
1	<ul style="list-style-type: none"> U/V/W-phase of amplifier is short circuited due to the wiring in amplifier and motor. Also, U/V/W-phases are grounded in the earth. 	<ul style="list-style-type: none"> Check the wiring between the amplifier and motor, and confirm that there is no error. If some error is detected, modify or change the wiring.
2	<ul style="list-style-type: none"> Short circuit or fault in U/V/W phases on servo motor side. 	<ul style="list-style-type: none"> Replace the servo motor.
3	<ul style="list-style-type: none"> Defect in control print panel Defect in power device 	<ul style="list-style-type: none"> Replace the servo amplifier.
4	<ul style="list-style-type: none"> Overheat is detected in Power device (IPM). 	<ul style="list-style-type: none"> Confirm that the cooling fan motor for the servo amplifier is working. If it is not working, replace the servo amplifier. Confirm that the temperature of the control panel (ambient temperature of the servo amplifier) does not exceed 55°C. If in excess of 55(C, check the installation method of the servo amplifier, and confirm that the cooling temperature of the control panel is set to below 55°C

Alarm code 22H (Current Detection Error 0)



Status during alarm	Cause	
	1	2
Issued when the control power is turned ON.	V	(V)
Issued after the power is turned ON.	(V)	V

Corrective actions

Cause		Investigation and corrective actions
1	<ul style="list-style-type: none"> Defect in control print panel Defect in power device 	<ul style="list-style-type: none"> Replace the servo amp.
2	<ul style="list-style-type: none"> Servo amplifier and motor are not combined properly 	<ul style="list-style-type: none"> Confirm that the proper codes (per the specified Motor Codes) have been used for the servo motor; if not, replace the servo motor.

Note) V means the cause number with high possibility. (V) means the cause number with middle possibility.

8.Maintenance

[Trouble shooting when alarm occurs]

Alarm code 23H (Current Detection Error 1)

Alarm code 24H (Current Detection Error 2)

Status during alarm	Cause	
	1	2
Issued when the control power is turned ON.	V	
Issued during operation.	(V)	V



Corrective actions

Cause	Investigation and corrective actions
1 • Defect in internal circuit of servo amplifier.	• Replace the servo amplifier.
2 • Malfunction due to noise	• Confirm proper grounding of the amplifier. • Add ferrite core or similar countermeasures against noise.



Alarm code 41H (Overload 1)

Status during alarm	Cause								
	1	2	3	4	5	6	7	8	9
Issued when power supply control is turned ON.	V								
Issued at input of servo ON.	V	V							V
After command input, issued without rotating the motor.		V			V	V	V		V
After command input, brief motor rotation			V	V	V		(V)	V	

Corrective actions

Cause	Investigation and corrective actions
1 • Defect in servo amplifier control panel or power element peripheral	• Replace the servo amplifier.
2 • Defect in encoder circuit of servomotor	• Replace the servo motor.
3 • Effective torque exceeds the rated torque.	• Monitor the load status using motor usage ratio monitor (OPRT), and check if effective torque exceeds the rated value. • Or, calculate the motor effective torque from load conditions and operation conditions. →If the effective torque is excessive, check the operating or loading, or replace the capacity of the large motor.
4 • Defect in motor-amplifier combination	• Check if the motor in use matches with the recommended type, and replace if it is improper.
5 • Holding brake of servo motor does not release.	• Check that the wiring and voltage of the holding brake are acceptable; if not, repair. →If the above are OK, replace the servomotor.
6 • Wiring of U/V/W –phase between servo amplifier and motor do not match.	• Check the wiring conditions and restore if improper.
7 • One or all connections of U/V/W -phase wiring of servo amplifier / motor is disconnected	• Check the wiring conditions and restore if improper.
8 • Machines collided.	• Check the operating conditions and limit switch.
9 • Encoder pulse number setting does not match with the motor.	• Match the encoder pulse number with the motor.



During the alarm caused by conditions in #3 (above), if OFF → ON of power supply control is repeated, there is a risk of burning out the servo motor. Wait for longer than 30 min. for cooling purposes after power shut OFF, and resume operations.

Note) V means the cause number with high possibility. (V) means the cause number with middle possibility.

8.Maintenance

[Trouble shooting when alarm occurs]

Alarm code 42H (Overload 2)



Status during alarm	Cause								
	1	2	3	4	5	6	7	8	9
Issued when power supply control is turned ON.	V								
Issued at input of servo ON.	V	V							V
After command input, issued without rotating the motor.		V			V	V	V		V
After command input, brief motor rotation			V	V	V		(V)	V	

Corrective actions

Cause		Investigation and corrective actions
1	<ul style="list-style-type: none"> Defect in servo amplifier control panel or power element peripheral 	<ul style="list-style-type: none"> Replace the servo amplifier.
2	<ul style="list-style-type: none"> Defect in encoder circuit of servomotor 	<ul style="list-style-type: none"> Replace the servo motor.
3	<ul style="list-style-type: none"> Rotation is less than 50min⁻¹ and torque command exceeds approx. 2 times of rated torque. 	<ul style="list-style-type: none"> Check if torque command exceeds approx. 2 times of the rated torque by torque command monitor (TCMON). Or, calculate the motor effective torque from load conditions and operation conditions. →If the effective torque is excessive, check the operating or loading, or replace the capacity of the large motor.
4	<ul style="list-style-type: none"> Defect in motor-amplifier combination 	<ul style="list-style-type: none"> Check the motor type setting and the motor in use are matching. If not, correct them.
5	<ul style="list-style-type: none"> Holding brake of servo motor does not release. 	<ul style="list-style-type: none"> Check that wirings and voltage for holding brake are correct. If not, repair them. →If they are appropriate, replace the servo motor.
6	<ul style="list-style-type: none"> Wiring of U/V/W -phase between servo amplifier and motor do not match. 	<ul style="list-style-type: none"> Check the wiring conditions and restore if improper.
7	<ul style="list-style-type: none"> One or all connections of U/V/W -phase wiring of servo amplifier / motor is disconnected 	<ul style="list-style-type: none"> Check the wiring conditions and restore if improper.
8	<ul style="list-style-type: none"> Machines collided. 	<ul style="list-style-type: none"> Check the operating conditions and limit switch.
9	<ul style="list-style-type: none"> Encoder pulse number setting does not match with the motor. 	<ul style="list-style-type: none"> Match the encoder pulse number with the motor.

Alarm code 43H (Regenerative Error)



Status during alarm	Cause							
	1	2	3	4	5	6	7	8
Issued when power supply control is turned ON.							V	
Issued when power supply of main circuit is turned ON.						V	V	V
Issued during operation.	V	V	V	V	V		(V)	

Corrective actions

Cause		Investigation and corrective actions
1	<ul style="list-style-type: none"> Exceeded permitted value of regenerating power in built-in regenerative resistance specifications. Excessive load inertia, or tact time is short. 	<ul style="list-style-type: none"> Check the load inertia and operating pattern. Use an external regeneration resistor. Set the load inertia within the specified range. Increase the deceleration time. Increase the tact time.
2	<ul style="list-style-type: none"> Regenerative resistance wiring conflicts with built-in regenerative resistance specifications. 	<ul style="list-style-type: none"> Check wiring and replace if incorrect.
3	<ul style="list-style-type: none"> Regenerative resistance wiring conflicts with external regeneration resistor specifications. 	<ul style="list-style-type: none"> Check wiring and replace if incorrect.
4	<ul style="list-style-type: none"> Regeneration resistor is disconnected. 	<ul style="list-style-type: none"> For built-in regeneration resistor specifications, replace the servo amplifier. For external regeneration resistor specifications, replace the regeneration resistor.
5	<ul style="list-style-type: none"> Resistance value of external regeneration resistor is excessive. 	<ul style="list-style-type: none"> Replace the current resistance value with a value matching the specifications.
6	<ul style="list-style-type: none"> Input power supply voltage exceeds the specified range. 	<ul style="list-style-type: none"> Check the input power supply voltage level.
7	<ul style="list-style-type: none"> Defect in control circuit of servo amplifier. 	<ul style="list-style-type: none"> Replace the servo amplifier.
8	<ul style="list-style-type: none"> When external regenerative resistance is selected for system parameter Page OB and external regenerative resistance is not installed. 	<ul style="list-style-type: none"> Install the external regenerative resistance. Set to "Do not connect regenerative resistance".

If the setting of system parameter page 0B regeneration resistance is incorrect, regeneration error is not detected properly, and the amplifier and surrounding circuit may be damaged or burnt.

Note) V means the cause number with high possibility. (V) means the cause number with middle possibility.

8.Maintenance

[Trouble shooting when alarm occurs]

Alarm code 51H (Amplifier Overheat)

Status during alarm	Cause				
	1	2	3	4	5
Issued when power supply control is turned ON.	(V)		V	(V)	
Issued during operation.	(V)	V	V	V	
Issued after emergency stop.					V



Corrective actions

Cause		Investigation and corrective actions
1	• Defect in internal circuit of servo amplifier.	• Replace the servo amplifier.
2	• Regenerating power exceeded.	• Check the operating conditions. • Use external regeneration resistor.
3	• Regenerating power is within the specified range but ambient temperature of servo amplifier is out of specified range.	• Confirm that the cooling method maintains the temperature of control panel between 0 to 55°C.
4	• Regenerating power is within the specified range but built-in cooling fan of servo amplifier is stopped.	• For an amplifier equipped with a fan motor, check that the fan motor is running; if not, replace the servo amplifier.
5	• Regeneration energy during emergency stop exceeded.	• Change the servo amp. • Check the loading condition.



Abnormalities are detected in the internal temperature of the amplifier regardless of its ambient temperature. When an amplifier ambient temperature warning is issued, please be sure to check the cooling method of the control panel.

Alarm code 52H (RS Overheat) [only for RS1□30]

Status during alarm	Cause		
	1	2	3
Issued when power supply is turned ON.	V		
Issued when main circuit power supply is turned ON.		V	
Issued during operation.			V



Corrective actions

Cause		Investigation and corrective actions
1	Defect in internal circuit of servo amplifier.	Replace the servo amplifier
2	• Power turning ON is repeated too frequently.	• Turn ON/OFF the power less frequently.
3	• Ambient temperature is high.	• For a servo amplifier equipped with a cooling fan motor, check that the fan motor is running properly. If not, replace the servo amplifier. • Check if the temperature inside the control panel (servo amplifier ambient temperature) exceeds 55°C. If it does, review the servo amplifier installing method and cooling method of control panel to make it below 55°C.

Note) V means the cause number with high possibility. (V) means the cause number with middle possibility.

8.Maintenance [Trouble shooting when alarm occurs]

Alarm code 53H (Dynamic Brake Resistor Overheat)

Status during alarm	Cause	
	1	2
Issued when power supply is turned ON.	V	
Issued during operation.	(V)	V



Corrective actions

	Cause	Investigation and corrective actions
1	• Defect in internal circuit of servo amplifier.	• Replace the servo amplifier.
2	• DB operation frequency exceeded.	• Use the dynamic brake so as not to exceed the permissive frequency.

Alarm code 54H (Internal Overheat)

Status during alarm	Cause		
	1	2	3
Issued when power supply control is turned ON.	(V)		V
Issued during operation.	(V)	V	V



Corrective actions

	Cause	Investigation and corrective actions
1	• Defect in internal circuit of servo amplifier.	• Replace the servo amplifier.
2	• Regenerating power excessive.	<ul style="list-style-type: none"> • Check the built-in regenerative resistance absorption power. • Check the operating conditions, so that regenerating power is within permitted absorption power. • Use an external regeneration resistor.
3	• Improper wiring of built-in regeneration resistor.	• Confirm improper condition and repair if necessary.



When using a regeneration resistance built in the servo amplifier, make sure to set "built-in regeneration resistance" at system parameter Page 0B [Regeneration resistance type]. This setting makes the judgment between enabled/disabled of the overheating protection detection treatment of the built-in regeneration resistance. When "No connected regenerative resistance or external regenerative resistance" is selected, overheating of built-in regenerative resistance is not detected. Therefore, there is a danger that built-in regenerative resistance will burn out or be damaged.

Note) V means the cause number with high possibility. (V) means the cause number with middle possibility.

8.Maintenance [Trouble shooting when alarm occurs]

Alarm code 55H (External Error)

When external regenerative resistor and output terminal of upper device are not connected

Status during alarm	Cause	
	1	2
Issued when power supply control is turned ON.	V	(V)



Corrective actions

Cause		Investigation and corrective actions
1	• Validity condition for external trip function is set to 'Valid'.	• When not used, set 00:_Always_Disable at Group9 40.
2	• Defect in control panel of servo amplifier.	• Replace the servo amplifier.

When external regenerative resistor is connected

Status during alarm	Cause		
	1	2	3
Issued when power supply control is turned ON.	V		(V)
Issued after operation.		V	(V)

Corrective actions

Cause		Investigation and corrective actions
1	• Improper wiring of external regenerative resistance.	• Check wiring and replace if necessary.
2	• External regeneration resistor is operating.	• Check the operating conditions. • Increase the capacity of the external regeneration resistor.
3	• Defect in control panel of servo amplifier.	• Replace the servo amplifier.

When output terminal of upper level device is connected:

→ Eliminate the alarm trigger of the upper level device.

Note) V means the cause number with high possibility. (V) means the cause number with middle possibility.

8.Maintenance [Trouble shooting when alarm occurs]

Alarm code 61H (Overvoltage)

Status during alarm	Cause			
	1	2	3	4
Issued when power supply control is turned ON.	V			
Issued when power supply of main circuit is turned ON.	V	V		
Issued at the time of motor start/stop.		(V)	V	V



Corrective actions

Cause	Investigation and corrective actions
1 • Defect in control panel of servo amplifier.	• Replace the servo amplifier.
2 • The power supply voltage of main circuit exceeds the rated value.	• Reduce the power supply voltage to within the specified range.
3 • Excessive load inertia.	• Reduce the load inertia to within the specified range.
4 • Incorrect wiring for regeneration resistance • Built-in regeneration circuit is not functioning.	• Wire the regeneration resistance correctly. • While using the external regenerative resistance, check the wiring and resistance value. • Replace the servo amplifier if any abnormality occurs.

Alarm code 62H (Main Circuit Undervoltage)

Status during alarm	Cause				
	1	2	3	4	5
Issued when power supply control is turned ON.				V	(V)
Issued after power supply of main circuit is turned ON.	V	V			
Issued during operation, alarm resetting is possible.		(V)	V		
Issued during operation, alarm resetting is not possible.		V			



Corrective actions

Cause	Investigation and corrective actions
1 • Power supply voltage is below the specified range.	• Check the power supply and set it within the specified range.
2 • Rectifier of main circuit is broken.	• Replace the servo amplifier.
3 • Input voltage is reduced and/or blinking.	• Check the power supply and confirm that there is no blinking or low voltage.
4 • Low voltage outside of the specified range is supplied to the main circuit (R/S/T).	• Check the main circuit voltage. Confirm that there is no external power supply to R/S/T when the main circuit is OFF.
5 • Defect in internal circuit of the servo amplifier.	• Replace the servo amplifier.

Note) V means the cause number with high possibility. (V) means the cause number with middle possibility.

8.Maintenance

[Trouble shooting when alarm occurs]

Alarm code 63H (Main Power Supply Fail Phase)



Status during alarm	Cause		
	1	2	3
Issued when power supply control is turned ON.		V	
Issued when power supply of main circuit is turned ON.	V		V
Issued during motor operations.	(V)		
Alarm issued during single-phase power input selection.			V

Corrective actions

Cause		Investigation and corrective actions
1	• One out of 3 phases (R/S/T) is not inserted.	• Check the wiring and repair if necessary.
2	• Defect in internal circuit of Servo amplifier.	• Replace the servo amplifier.
3	• Servo amplifier is not specified for single phase.	• Check the model number and delivery specifications of the servo amplifier and replace it with a servo amplifier for single-phase power supply. • Edit the parameters and use a single-phase specification amplifier.

Alarm code 71H (Control Power Supply Undervoltage)



Status during alarm	Cause		
	1	2	3
Issued at the time of power on.	(V)	V	
Issued during operation.	(V)		V

Corrective actions

Cause		Investigation and corrective actions
1	• Defect in internal circuit of the servo amplifier.	• Replace the servo amplifier.
2	• Power supply voltage is within the specified range.	• Confirm that the power supply is set within the specified range.
3	• Input voltage is fluctuating or stopped.	• Confirm that the power supply is not going to neither stop nor reduce the power.

Alarm code 72H (Control Power Error)



Status during alarm	Cause	
	1	2
Issued when power supply control is turned ON.	(V)	V

Corrective actions

Cause		Investigation and corrective actions
1	• Defect in internal circuit of the servo amplifier.	• Replace the servo amplifier.
2	• Defect in external circuit	• Restart the power supply after removing the connector; if alarm is not issued, check the external circuit. • Restart the power supply after replacing the motor; if alarm is not issued, there is defect in the encoder's internal circuit.

Note) V means the cause number with high possibility. (V) means the cause number with middle possibility.

8.Maintenance

[Trouble shooting when alarm occurs]

Alarm code 81H (Encoder Pulse Error 1/ A-phase, B-phase, and Z-phase)

Alarm code 82H (Absolute Encoder Signal Disconnect)

Alarm code 83H (External encoder A-phase/ B-phase signal abnormality)

Alarm code 84H (Communication Error between Encoder and Amplifier)

Alarm code 87H (CS Signal Disconnection)

Status during alarm	Cause					
	1	2	3	4	5	6
Issued when power supply control is turned ON.	V	V	V	V	V	V
Issued after servo is turned ON.				V	V	
Issued during operation.	(V)			V	V	

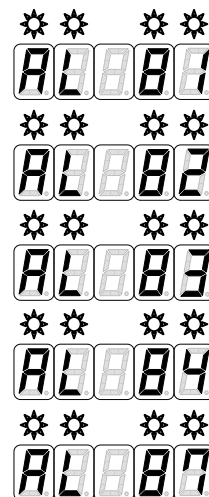

Corrective actions

Cause		Investigation and corrective actions
1	For encoder wiring: • Improper wiring • Connector is removed • Loose connection • Encoder cable is too long • Encoder cable is too thin	<ul style="list-style-type: none"> • Check wiring and repair any abnormality. • Confirm that the encoder power supply voltage of the motor is above 4.75 V; increase it if below 4.75 V.
2	• Wrong amplifier encoder type is selected.	• Select the correct encoder type.
3	• Motor encoder that does not match with amplifier encoder type is attached.	• Replace with servo motor equipped with proper encoder.
4	• Defect in servo amplifier control circuit	• Replace the servo amplifier.
5	• Defect in servo motor encoder	• Replace the servo motor.
6	• Parameter set to 'Full-close/Servo system'.	• Edit the parameter and set to 'Semi-close/System setup'.

Alarm code 85H (Encoder Initial Process Error)

Status during alarm	Cause				
	1	2	3	4	5
Issued when power supply control is turned ON.	V	V	V	V	(V)



Corrective actions

Cause		Investigation and corrective actions
1	For encoder wiring: • Improper wiring • Connector is removed • Loose connection • Encoder cable is too long • Encoder cable is too thin	<ul style="list-style-type: none"> • Check wiring and repair any abnormality. • Confirm that the encoder power supply voltage of the motor is above 4.75 V; increase it if below 4.75 V.
2	• Wrong parameter of amplifier encoder type or Group C Page 00 is selected.	• Select the correct parameter.
3	• Defect in servo amplifier control circuit	• Replace the servo amplifier.
4	• Defect in servo motor encoder	• Replace the servo motor.
5	• Initial position data could not be set, as the number of rotations of the motor is more than 250 min -1 during power supply.	• Restart the power supply after motor is stopped. (Only when PA035C and PA035S encoder is used.)

Note) V means the cause number with high possibility. (V) means the cause number with middle possibility.

8.Maintenance

[Trouble shooting when alarm occurs]

Alarm code 91H (Encoder Command Error)

Alarm code 92H (Encoder FORM Error)

Alarm code 93H (Encoder SYNC Error)

Alarm code 94H (Encoder CRC Error)

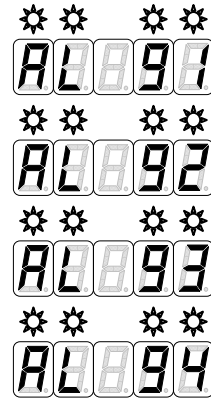

When abnormalities are detected in the internal part of the absolute position detector for the start-stop synchronization system.

Status during alarm	Cause		
	1	2	3
Issued when control power supply is turned ON.	(V)	V	V

Corrective actions

Cause	Investigation and corrective actions
1 • Defect in encoder	• Replace the servo motor.
2 • Malfunction due to noise	• Confirm proper grounding of the amplifier. • Check the shielding of the encoder cable. • Add ferrite core or similar countermeasures against noise.
3 • Abnormality in encoder wiring.	• Check wiring between the encoder and amplifier.

Alarm code A1H (Encoder Error 1)

When abnormalities are detected in the internal part of the absolute position detector (RA062M) for the Manchester encoding system.



Status during alarm	Cause
	1
Issued when power supply is turned ON.	V
Issued during operation.	V

Corrective actions

Cause	Investigation and corrective actions
1 • Defect in internal circuit of encoder	• Turn ON the power supply again; if not restored, replace the motor.

"Encoder clearing and alarm resetting methods" vary depending on the encoder in use. Refer to page 71 "Materials; Encoder Clear".

Alarm code A2H (Absolute Encoder Battery Error)



Status during alarm	Cause	
	1	2
Issued when control power is turned ON.	V	V
Issued during operation.		V

Corrective actions

Cause	Investigation and corrective actions
1 • Loose connection of battery cable.	• Confirm the battery connection in the front ON/OFF switch of the amplifier.
2 • Low battery voltage	• Check the battery voltage.

"Encoder clearing and alarm resetting methods" vary depending on the encoder in use. Refer to page 71 "Materials; Encoder Clear".

Note) V means the cause number with high possibility. (V) means the cause number with middle possibility.

8.Maintenance

[Trouble shooting when alarm occurs]

Alarm code A3H (Encoder Overheat)

When abnormalities are detected in the internal part of the absolute position detector for the start-stop synchronization system.

Status during alarm	Cause		
	1	2	3
Issued when control power supply is turned ON.	(V)	V	
Issued while stopping the motor.	(V)	V	
Issued during motor operations.		V	V



Corrective actions

Cause		Investigation and corrective actions
1	• Defect in internal circuit of encoder	• Turn ON the power supply again; if not restored, replace the motor.
2	• Motor is not generating heat, but encoder ambient temperature is high.	• Confirm that the cooling method keeps the encoder ambient temperature below 80°C.
3	• Motor is overheated.	• Confirm the cooling procedure of the servo motor. • Check the operating or loading, or replace the capacity of the large motor.

"Encoder clearing and alarm resetting methods" vary depending on the encoder in use. Refer to page 71 "Materials; Encoder Clear".

Alarm code A5H (Encoder Error 3)

When abnormalities are detected in the internal part of the absolute position detector for the start-stop synchronization system.

Status during alarm	Cause		
	1	2	3
Issued when power supply is turned ON.	(V)	V	V
Issued during motor operations.	(V)	V	



Corrective actions

Cause		Investigation and corrective actions
1	• Defect in internal circuit of encoder	• Turn ON the power supply again; if not restored, replace the motor.
2	• Malfunction due to noise	• Confirm proper grounding of the amplifier. • Check the shielding of the encoder cable. • Add ferrite core or similar countermeasures against noise.
3	• Number of rotations exceeds the permitted number of rotations.	• Turn ON the power supply again, when motor is stopped.

"Encoder clearing and alarm resetting methods" vary depending on the encoder in use. Refer to page 71 "Materials; Encoder Clear".

Note) V means the cause number with high possibility. (V) means the cause number with middle possibility.

8.Maintenance

[Trouble shooting when alarm occurs]

Alarm code A6H (Encoder Error 4)

When abnormalities are detected in the internal part of the absolute position detector for the start-stop synchronization system.

Status when alarm rings.	Cause		
	1	2	3
Issued when power supply is turned ON.	V	V	
Issued during motor operations.		V	V



Corrective actions

Cause		Investigation and corrective actions
1	• Defect in internal circuit of encoder	• Turn ON the power supply again; if not restored, replace the motor.
2	• Malfunction due to noise	• Confirm proper grounding of the amplifier. • Check the shielding of the encoder cable. • Add ferrite core or similar countermeasures against noise.



"Encoder clearing and alarm resetting methods" vary depending on the encoder in use. Refer to page 71 "Materials; Encoder Clear".

Alarm code A7H (Encoder Error 5)

Alarm code A8H (Encoder Error 6)

Alarm code A9H (Failure of Encoder)

When abnormalities are detected in the internal part of the absolute position detector for the start-stop synchronization system.

Status during alarm	Cause	
	1	2
Issued when power supply is turned ON.	V	V
Issued during motor operations.	(V)	V

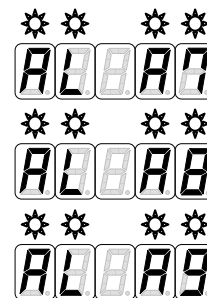

Corrective actions

Cause		Investigation and corrective actions
1	• Defect in internal circuit of encoder	• Turn ON the power supply again; if not restored, replace the motor.
2	• Malfunction due to noise	• Confirm proper grounding of the amplifier. • Check the shielding of the encoder cable. • Add ferrite core or similar countermeasures against noise.



"Encoder clearing and alarm resetting methods" vary depending on the encoder in use. Refer to page 71 "Materials; Encoder Clear".

Note) V means the cause number with high possibility. (V) means the cause number with middle possibility.

8.Maintenance

[Trouble shooting when alarm occurs]

Alarm Code B2H (Encoder Error 2)

When abnormality is detected in the internal part of the absolute position detector (RAO62M) of the Manchester system.

Status during alarm	Cause	
	1	2
Issued during operation.	(V)	V



Corrective actions

Cause	Investigation and corrective actions
1 • Defect in internal circuit of encoder	• Turn ON the power supply again; if not restored, replace the motor.
2 • Malfunction due to noise	• Confirm proper grounding of the amplifier. • Check the shielding of the encoder cable. • Add ferrite core or similar countermeasures against noise.

"Encoder clearing and alarm resetting methods" vary depending on the encoder in use. Refer to page 71 "Materials; Encoder Clear".

Alarm code B3H (Absolute Encoder Multi-Turn Counter Error)

Alarm code B4H (Absolute Encoder Single-Turn Counter Error)

Alarm code B6H (Encoder Memory Error)

When abnormalities are detected in the internal part of the absolute position detector for the start-stop synchronization system.

Status during alarm	Cause	
	1	2
Issued when control power supply is turned ON.	V	
Issued while operation.	(V)	V

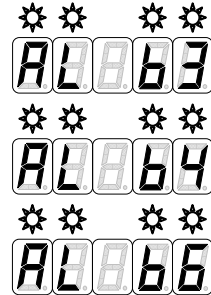

Corrective actions

Cause	Investigation and corrective actions
1 • Defect in internal circuit of encoder	• Turn ON the power supply again; if not restored, replace the motor.
2 • Malfunction due to noise	• Confirm proper grounding of the amplifier. Check the shielding of the encoder cable. • Add ferrite core or similar countermeasures against noise.

"Encoder clearing and alarm resetting methods" vary depending on the encoder in use. Refer to page 71 "Materials; Encoder Clear".

Note) V means the cause number with high possibility. (V) means the cause number with middle possibility.

8.Maintenance

[Trouble shooting when alarm occurs]

Alarm code B5H

(Over-allowable Speed of Absolute Encoder at Turning ON)

When abnormalities are detected in the internal part of the absolute position detector for the start-stop synchronization system.

Status during alarm	Cause		
	1	2	3
Issued when power supply is turned ON.	V		(V)
Issued while stopping the motor.	V	V	
Issued while rotating the motor.	(V)	V	V



Corrective actions

Cause	Investigation and corrective actions
1 • Defect in internal circuit of encoder	• Turn ON the power supply again; if not restored, replace the motor.
2 • Malfunction due to noise	• Confirm proper grounding of the amplifier. • Check the shielding of the encoder cable. • Add ferrite core or similar countermeasures against noise.
3 • Number of motor rotations exceeds the permitted speed.	• Check the operation pattern and reduce the maximum number of rotations.



"Encoder clearing and alarm resetting methods" vary depending on the encoder in use. Refer to page 71 "Materials; Encoder Clear".

Alarm code B7H (Acceleration Error)

When abnormalities are detected in the internal part of the absolute position detector for the start-stop synchronization system.

Status during alarm	Cause		
	1	2	3
Issued while stopping the motor.	V	V	
Issued while rotating the motor.	(V)	V	V



Corrective actions

Cause	Investigation and corrective actions
1 • Defect in internal circuit of encoder	• Turn ON the power supply again; if not restored, replace the motor.
2 • Malfunction due to noise	• Confirm proper grounding of the amplifier. Check the shielding of the encoder cable. • Add ferrite core or similar countermeasures against noise.
3 • The acceleration of motor rotation exceeds the permitted acceleration	• Check the operation pattern, and extend the acceleration and deceleration time.



"Encoder clearing and alarm resetting methods" vary depending on the encoder in use. Refer to page 71 "Materials; Encoder Clear".

Note) V means the cause number with high possibility. (V) means the cause number with middle possibility.

8.Maintenance

[Trouble shooting when alarm occurs]

Alarm code C1H (Overspeed)



Status during alarm	Cause			
	1	2	3	4
Issued when control power supply is turned ON.	V	(V)		
Issued if command is entered after Servo ON	(V)	V		
Issued when the motor is started.			V	V
Issued other than operating and starting the motor		V	V	

Corrective actions

Cause		Investigation and corrective actions
1	• Defect in control panel of servo amplifier.	• Replace the servo amplifier.
2	• Defect in the encoder of servo motor	• Replace the servo motor.
3	• Excessive overshoot while starting.	• Monitor speed with the analog monitor. →Adjust the servo parameters if overshoot is excessive. →Simplify the acceleration and deceleration command pattern. →Reduce the load inertia.
4	• Wiring of U/V/W -phase between servo amplifier and motor do not match.	• Check the wiring and repair any irregularities.

Note) V means the cause number with high possibility. (V) means the cause number with middle possibility.

8.Maintenance

[Trouble shooting when alarm occurs]

Alarm code C2H (Speed Control Error)



Status during alarm	Cause				
	1	2	3	4	5
Issued when control power supply is turned ON.					V
Issued while due to input of Servo ON	V		V		
Issued if command is entered.	V	V	V		
Issued while starting and stopping the motor.				V	

Corrective actions

Cause	Investigation and corrective actions
1 • Wiring of U/V/W -phase between servo amplifier and motor do not match.	• Check the wiring and repair any irregularities.
2 • The wiring of A, B phase of INC-E and ABS-EI encoder connection is incorrect.	• Check the wiring and repair any irregularities.
3 • The motor is vibrating (oscillating).	• Adjust the servo parameters so that servo motor will not vibrate (oscillate).
4 • Excessive overshoot and undershoot.	• Monitor speed with the analog monitor. • Adjust the servo parameters to reduce overshoot and undershoot. • Increase acceleration and deceleration command time. Mask the alarm.
5 • Abnormality in servo amplifier control circuit	• Replace the servo amplifier.



For the speed control error alarm, an alarm may occur while starting and stopping when load inertia is excessive. For this reason, in the gravitational axis applications, "Do not detect" is selected as the standard setting. If its detection is needed, consult our representatives.

Alarm code C3H (Speed Feedback Error)



Status during alarm	Cause		
	1	2	3
Issued when command is entered.	V	(V)	V

Corrective actions

Cause	Investigation and corrective actions
1 • Motor is not rotating.	• Confirm that the power line is properly connected. • Replace the servo motor.
2 • Defect in internal circuit of servo amplifier.	• Replace the servo amplifier.
3 • The motor is vibrating (oscillating).	• Adjust the servo parameter so that servo motor will not vibrate (oscillate).

Note) V means the cause number with high possibility. (V) means the cause number with middle possibility.

8.Maintenance

[Trouble shooting when alarm occurs]

Alarm code D1H (Following Error / Excessive Position Deviation)



Status during alarm	Cause											
	1	2	3	4	5	6	7	8	9	10	11	12
Issued when control power supply is turned ON.										V		
Issued when servo ON is stopped.						V					V	
Issued immediately after entering the command.	V	(V)	V	V	V		V	(V)	V		(V)	
Issued during starting or stopping at high speed.	V	V					V	V	V		(V)	V
Issued during the operations by lengthy command.		V					V	(V)			(V)	

Corrective actions

Cause		Investigation and corrective actions
1	• Position command frequency is high or acceleration and deceleration time is short.	• Correct the position command of the controller
2	• Excessive initial load or low motor capacity.	• Correct the load condition or increase the motor capacity
3	• Holding brake is not released.	• Check the wiring and repair any abnormalities. If specified voltage is applied, replace the servo motor.
4	• Motor is mechanically locked or machine is colliding.	• Check the machinery system.
5	• One or all phases of U/V/W -phase of the servo amplifier and motor has disconnected.	• Check and repair the wiring connections.
6	• Motor is being rotated by an external force (Gravity, etc.) during stopping (positioning completion).	• Check the load, and/or increase the motor capacity.
7	• Valid current limit command is entered by the controller, and the current limit setting is reduced. • Number of encoder pulses does not match with the motor.	• Increase the current limit value or disable the current limit. • Match the number of motor encoder pulses.
8	• Settings of servo parameters (Position loop gain, etc.) are not appropriate.	• Check the servo parameter settings (Raise the position loop gain, etc.)
9	• Excessive deviation setting value is reduced.	• Set a greater value for excessive deviation.
10	• Defect in control panel of servo amplifier.	• Replace the servo amplifier.
11	• Servo motor encoder is defective.	• Replace the servo motor.
12	• Power supply voltage is low.	• Check the power supply voltage.

Alarm code D2H (Faulty Position Command Pulse Frequency 1)



Status during alarm	Cause
	Issued after entering position command pulse.

Corrective actions

Cause		Investigation and corrective actions
1	• Command for the digital filter setting of the command pulse input is entered	• Decrease the frequency of the command pulse. • Increase the frequency of the digital filter.

Note) V means the cause number with high possibility. (V) means the cause number with middle possibility.

8.Maintenance [Trouble shooting when alarm occurs]

Alarm code D3H (Faulty Position Command Pulse Frequency 2)

Status during alarm	Cause	
	1	2
Issued after entering position command pulse.	V	V



Corrective actions

Cause		Investigation and corrective actions
1	• Frequency of command pulse input is excessive.	• Reduce the frequency of command pulse input.
2	• Setting value of electronic gear is excessive.	• Decrease the electronic gear setting value.

Alarm code DFH (Test Run Close)

Status during alarm	Cause
	1
Occurred after execution of test mode.	V



Corrective actions

Cause		Investigation and corrective actions
1	• Normal operation.	• Clear the alarm and restore operation. (After completion of test mode, to confirm any deviation in the controller).

Alarm code E1H (EEPROM Error)

Status during alarm	Cause	
	1	2
Issued when control power supply is turned ON.	V	(V)
Issued during display key operation or set up software operation.		V



Corrective actions

Cause		Investigation and corrective actions
1	• Correct value not read by CPU by nonvolatile memory of built-in servo amplifier.	• Replace the servo amplifier.
2	• Defect in the servo amplifier control panel	• Replace the servo amplifier.

Note) V means the cause number with high possibility. (V) means the cause number with middle possibility.

8.Maintenance [Trouble shooting when alarm occurs]

Alarm code E2H (EEPROM Check Sum Error)

Status during alarm	Cause	
	1	2
Issued when control power supply is turned ON.	(V)	V



Corrective actions

Cause	Investigation and corrective actions
1 <ul style="list-style-type: none"> Correct value not read by CPU by nonvolatile memory of built-in servo amplifier 	<ul style="list-style-type: none"> Replace the servo amplifier.
2 <ul style="list-style-type: none"> Failed to write into the nonvolatile memory during last power supply cutoff. 	<ul style="list-style-type: none"> Change the optional parameters, turn ON the power supply again, and confirm that alarm has cleared. →If alarm is not cleared, replace the servo amplifier.

Alarm code E3H (Internal RAM Error)

Alarm code E4H (Process Error between CPU and ASIC)

Status during alarm	Cause
	1
Issued when control power supply is turned ON.	V



Corrective actions

Cause	Investigation and corrective actions
1 <ul style="list-style-type: none"> Defect in the servo amplifier control panel 	<ul style="list-style-type: none"> Replace the servo amplifier.

Alarm code E5H (Parameter Error 1)

Status during alarm	Cause	
	1	2
Issued when control power supply is turned ON.	V	V
Issued after changing any of system parameters.	V	



Corrective actions

Cause	Investigation and corrective actions
1 <ul style="list-style-type: none"> Selected value is outside the specified range for a system parameter. 	<ul style="list-style-type: none"> Confirm the model number of the servo amplifier. Confirm selected values of system parameters and modify if necessary. →Turn ON the power again and confirm that alarm is cleared.
2 <ul style="list-style-type: none"> Defect in servo amplifier 	<ul style="list-style-type: none"> Replace the servo amplifier.

Note) V means the cause number with high possibility. (V) means the cause number with middle possibility.

8.Maintenance

[Trouble shooting when alarm occurs]

Alarm code E6H (Parameter Error 2)



Status during alarm	Cause	
	1	2
Issued when control power supply is turned ON.	V	V
Issued after changing any of system parameters.	V	

Corrective actions

Cause	Investigation and corrective actions
1 <ul style="list-style-type: none"> Selected values of system parameters and actual hardware do not match Improper assembly of system parameter settings. 	<ul style="list-style-type: none"> Confirm the model number of servo amplifier. Confirm selected values of system parameters and correct if necessary. →Turn ON the power again and confirm that alarm is cleared.
2 <ul style="list-style-type: none"> Defect in servo amplifier 	<ul style="list-style-type: none"> Replace the servo amplifier.

Alarm code F1H (Task Process Error)



Status during alarm	Cause
	1
Issued while operating.	V

Corrective actions

Cause	Investigation and corrective actions
1 <ul style="list-style-type: none"> Abnormality in control circuit of servo amplifier 	<ul style="list-style-type: none"> Replace the servo amplifier

Alarm code F2H (Initial Process Time-Out)

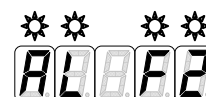

Status during alarm	Cause	
	1	2
Issued when control power supply is turned ON.	V	V

Corrective actions

Cause	Investigation and corrective actions
1 <ul style="list-style-type: none"> Defect in internal circuit of servo amplifier 	<ul style="list-style-type: none"> Replace the servo amplifier.
2 <ul style="list-style-type: none"> Malfunction due to noise 	<ul style="list-style-type: none"> Confirm proper grounding of the amplifier. Add ferrite core or similar countermeasures against noise.





Note) V means the cause number with high possibility. (V) means the cause number with middle possibility.

8.Maintenance

[Inspection/parts overhaul]

■ Inspection

For maintenance purposes, a daily inspection is typically sufficient. Upon inspection, refer to the following description.

Inspection location	Testing conditions			Inspection Items	Inspection Methods	Solution if abnormal
	Time	During operation	While stopping			
Servo motor	Daily	V		Vibration	Check for excessive vibration.	Contact dealer/sales office.
	Daily	V		Sound	Check if there is no abnormal sound as compared to normal sound.	
	Periodic		V	Cleanliness	Check for dirt and dust.	Clean with cloth or air. →  1
	Yearly		V	Measure value of insulation resistance	Contact the dealer or sales office.	
	5000 hours →  2		V	Replacement of oil seal		
Servo amplifier	Periodic		V	Cleaning	Check for dust accumulated in the accessories.	Clean with air. →  1
	Yearly		V	Loose screws	Check for loose connections	Fasten the screws properly.
absolute encoder back up battery	Regularly →  3		V	Battery voltage	Confirm that battery voltage is more than DC3.6V.	Replace the battery.
Temperature	On demand	V		Measure temperature	Ambient temperature Motor frame temperature	Set the ambient temperature within the limit. Check the load condition pattern.



1. While cleaning with air, confirm that there is no oil content and/or moisture in the air.
2. This inspection and replacement period is when water- or oil-proof functions are required.
3. The life expectancy of the battery is approximately 2 years, when its power is OFF throughout the year.
For replacement, a lithium battery (ER3V: 3.6V, 1000mAh) manufactured by TOSHIBA HOME APPLIANCES CORPORATION. is recommended.

■ Parts overhaul

Parts indicated in Table 9-5 may deteriorate over time. Perform periodic inspection for preventive maintenance.

No.	Part name	Number of average replacement years	Corrective measures / usage conditions
1	Condenser for smoothing main circuit	5 Years	Replacement with new part is necessary. Load ratio: 50% of rated output current of amplifier Usage condition: Average temp. 40°C year-round
2	Cooling Fan motor	5 Years	Replacement with new part is necessary. Usage condition: Average temp. 40°C year-round
3	Lithium battery for absolute encoder [ER3V]	3 Years	Replacement with new part is necessary.
4	Electrolysis condenser (other than condenser for smoothing main circuit)	5 Years	Replacement with new part is necessary. Usage condition: Average temp. 40°C year-round Annual usage period is 4800 hours
5	Fuse	10 Years	Replacement with new part is necessary.

1. Condenser for smoothing the main circuit

- If the servo amplifier is in use for more than 3 years, contact the dealer or sales office.
The capacity of the condenser for smoothing the main circuit is reduced due to the frequency of motor output current and power ON/ OFF during usage, and it may cause damage.
- When the condenser is used with an average 40°C throughout the year, and exceeds more than 50% of the rated output current of servo amplifier, it is necessary to replace the condenser with a new part every 5 years.
- When used in an application where the power turn ON/OFF is repeated more than 30 times a day, consult our representatives.

2. Cooling Fan motor

- The R-Series Amplifier is set corresponding to the degree of pollution specified in EN50178 or IEC 664-1. As it is not dust proof or oil proof, use it in an environment above Pollution Degree 2 (i.e., Pollution Degree 1, 2).
- R-Series servo amplifiers models RS1□03, RS1□05, RS1□10, RS1□15 and RS1□30 have a built-in cooling fan; therefore be sure to maintain a space of 50mm on the upper and lower side of the amplifier for airflow. Installation in a narrow space may cause damage due to a reduction in the static pressure of the cooling fan and/or degradation of electronic parts. Replacement is necessary if abnormal noise occurs, or oil or dust is observed on the parts. Also, at an average temperature of 40°C year-round, the life expectancy is 5 years.

3. Lithium battery

- The standard replacement period recommended by our company is the life expectancy of lithium battery based on normal usage conditions. However, if there is high frequency of turning the power ON/OFF, or the motor is not used for a long period, then the life of lithium battery is reduced. If the battery power is less than 3.6 V during inspection, replace it with a new one.

How to replace absolute encoder back-up battery

- (1) Turn ON the servo amplifier control power supply.
- (2) Prepare the replacement lithium battery. [SANYO DENKI model number: AL-00494635-01]
- (3) Open the servo amplifier front cover.
- (4) Remove the battery connector.
- (5) Take out the used lithium battery and put in the new replacement one (prepared in the above (2)).
- (6) Attach the connector in the right direction.
- (7) Close the servo amplifier front cover.

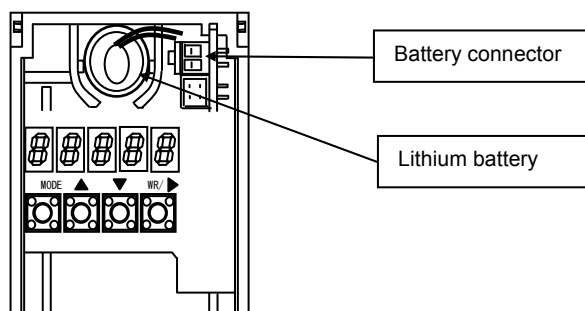

If the battery is replaced while the control power is OFF, multiple rotation counter (position data) of the absolute encoder may be unstable. When the amplifier control power is turned ON in this status, an alarm (battery error) may be issued. For this, execute encoder clear and alarm reset to release the alarm status. Also, absolute encoder position data may be unstable. Check and adjust the relations between position data and machine coordinate system.



SANYO DENKI-overhauled servo amplifier is shipped with the same parameters as the ones before overhauling. Be sure to confirm the parameters before use.

No Text on This Page.

[Specifications]

◆	Servo amplifier	9-1
◆	Pulse output	9-4
◆	Serial output	9-5
◆	General servo motor	9-23
◆	Rotation Direction Specifications	9-23
◆	Mechanical specifications	9-24
◆	Holding brake specifications	9-26

9. Specifications

[Servo amplifier]

■ General specifications

Basic specifications	Model number		RS1□01□	RS1□03□	RS1□05□	RS1□10□	RS1□15□	RS1□30□	
	Control function		Speed control, torque control, or position control (Parameter change)						
	Control system		IGBT PWM control Sinusoidal drive						
	*1 Input power	Main circuit	Three-phase AC200 to 230V+10, -15%, 50/60Hz±3Hz Single phase AC200 to 230V+10, -15%, 50/60Hz±3Hz*2 Single phase AC100 to 115V+10, -15%, 50/60Hz±3Hz*3						
		Controlling circuit	Single phase AC200 to 230V+10, -15%, 50/60Hz±3Hz Single phase AC100 to 115V+10, -15%, 50/60Hz±3Hz*3						
	Environment	Ambient temperature*4		0 to 55°C					
		Storage temperature		-20 to +65°C					
		Operating / storage humidity		Below 90%RH (no condensation)					
		Elevation		Below 1000 m					
		Vibration		0.5G Frequency range 10 to 55Hz Test for 2H in each direction X.Y.Z					
Shock		2G							
Structure		Built-in tray type power supply							
Mass Kg		0.9	1.0	2.2	5.2	6.5	10.5		
Performance	Speed control range*5		1:5000						
	In case of speed control specification		Frequency characteristics*7 600Hz (JL=JM)						
Built-in functions	Protection functions		Over current, Current detection error, Overload, Regeneration error, Amplifier overheating, External overheating, Over voltage, Main circuit low voltage, Main circuit open-phase, Control power supply error, Encoder error, Over speed, Speed control error, Speed feedback error, Excessive position error, Position command pulse error, CPU error, Built-in memory error, Battery error, Parameter error						
	LED display		Status display, Monitor display, Alarm display, Parameter settings, Adjustment mode						
	Dynamic brake		Built-in						
	Regeneration process		Built-in						
	Applied load inertia		Within the applied load inertia of combined servo motor						
	Monitor output	Speed monitor (VMON)		2.0V±10% (at 1000min ⁻¹)					
Torque monitor (TMON)		2.0V±10% (at 100%)							
Input / Output signal	For speed/torque control specification	Speed command	Command voltage	DC±2.0V (at 1000min ⁻¹ command, Forward motor rotation with positive command, maximum input voltage ±10V)					
			Input impedance	Approx. 10kΩ					
		Torque command	Command voltage	DC±2.0V (at 100% torque, Forward motor rotation with positive command)					
			Input impedance	Approx. 10kΩ					
		Torque limit input		DC±2.0V ±15% (at rated armature current)					
		Sequence input signal		Servo on, Alarm reset, Torque limit, Encoder clear, Forward rotation inhibition, Reverse rotation inhibition, Command inhibition, External trip, Forced discharge, Emergency stop, Change of control mode, Proportional control, Gain switch, Internal speed setting					
	Sequence output signal		Servo ready, Power ON, Servo ON, Holding brake timing, Within torque limit, Within speed limit, Low speed, velocity attainment, Matching speed, Zero speed, Command acceptable, Status of gain switch, Speed loop proportional control status, Control mode switchover status, Forward OT, Reverse OT, Warning, Alarm code (3Bit)						
	Position output signal (Pulse division)		N/8192 (N=1 to 8191), 1/N (N=1 to 64) or 2/N (N=3 to 64)						
	For position control specification	Position command	Maximum input pulse frequency	5M pulse/second (Reverse rotation Forward rotation pulse, symbol + Pulse), 1.25M pulse/second (90° phase difference Two phase pulse)					
			Input pulse type	Forward rotation + reverse rotation command pulse or symbol + pulse string command or 90° phase difference Two phase sequence command					
			Electronic gear	N/D (N=1 to 32767, D=1 to 32767) however, 1/32767 ≤ N/D ≤ 32767					
		Torque limit input		DC±2.0V ±15% (at Rated armature current)					
		Sequence input signal		Servo ON, Warning reset, Torque limit, Clear encoder, Forward rotation inhibition, Reverse rotation inhibition, Command inhibition, External trip, Forced discharge, Emergency stop, Deviation Clear, Change of control mode, Proportional control, Gain switch, Change of electronic gear, Position loop proportional control					
Sequence output signal		Servo ready, Power ON, Servo ON, Holding brake timing, Within torque limit, Within speed limit, Low speed, velocity attainment, Matching speed, Zero speed, Position fixed, Near range, Command acceptable, Status of gain switch, Speed loop proportional control status, Changed status of electronic gear, Changed control mode status, Forward OT, Reverse OT, Warning, Alarm code (3 bit)							
Position output signal (Pulse division)		N/8192 (N=1 to 8191), 1/N (N=1 to 64) or 2/N (N=3 to 64)							

9. Specifications

[Servo amplifier]

* 1 Source voltage should be within the specified range.

AC200V Power input type Specified power supply range AC170V to AC253V

AC100V Power input type Specified power supply range AC85V to AC127V

Install a step-down transformer if power supply exceeds the specified power supply.

* 2 AC200V single-phase input type corresponds only to RS1□01□/RS1□03□/RS1□05□.

* 3 AC100V single-phase input type corresponds only to RS1□01□/RS1□03□.

* 4 When stored in the box, be sure that internal temperature does not exceed this range.

* 5 Minimum rotational speed is determined as equivalent to the amplifier not stopping for a load with maximum

● Incoming current

Input voltage	Amplifier model name	Control circuit (Maximum value between 1ms after input)*3	Main circuit (Maximum value between 1.2 seconds after input)
AC200V	RS1□01□	40A (O-P)	18A (O-P)*1
	RS1□03□		
	RS1□05□		
	RS1□10□		
	RS1□15□		
AC100V	RS1□30□	20A (O-P)	9A (O-P)*2
	RS1□01□		
	RS1□03□		

* 1 Incoming current value is the maximum value when AC230V is supplied.

* 2 Incoming current value is the maximum value when AC115V is supplied.

* 3 Use thermistor for incoming current prevention circuit of power supply control.

When power is turned ON again after disconnection, power supply on/disconnection is repeated for short time, ambient temperature and temperature of thermistor is high, the incoming current exceeding the above mentioned table may pass.

● Current leakage

Since "R series" Servo amplifier drives the motor by PWM control of IPM, electric current leakage of high frequency flows through the floating capacity of motor winding, power cable or amplifier. Malfunction in short circuit breaker and protective relay installed in power supply electric circuit may occur. Use the inverter as electricity leakage breaker, which provides countermeasures for wrong operations.

Motor model number	Electric current leakage per motor
RS1□01□	0.5 mA
RS1□03□	0.5 mA
RS1□05□	1.5 mA
RS1□10□	3.0 mA
RS1□15□	3.0 mA
RS1□30□	5.0 mA

- While using 2 or more motors, electric current leakage each motor is added.
- Tough-rubber sheath cable of 2mm is used as power line, **in case of short system and long system of cable length**, value of above table should be selected as far as possible.
- The machine is grounded (type D (3rd type)) so that the dangerous voltage on the main part of a machine, operation panel, etc. does not arise at the time of an emergency leakage.
- The value of current leaked is the measured value in ordinary leak checkers (Filter 700Hz).

9. Specifications

[Servo amplifier]

● Calorific value

Input voltage	Amplifier capacity	Motor model number	Total calorific value of Servo amplifier(W)	Input voltage	Amplifier capacity	Motor model number	Total calorific value of Servo amplifier(W)
AC200V	RS1□01A	Q1AA04003D	11	AC200V	RS1□15A	Q1AA13400D	146
		Q1AA04005D	15			Q1AA13500D	169
		Q1AA04010D	18			Q1AA18450M	160
		Q1AA06020D	24			Q2AA18350H	138
		Q2AA04006D	12			Q2AA18450H	154
		Q2AA04010D	19			Q2AA18550R	201
		Q2AA05005D	16			Q2AA22550B	191
		Q2AA05010D	19			Q2AA22700S	222
		Q2AA05020D	26			R2AA18350D	134
		Q2AA07020D	32			R2AA18450H	153
		Q2AA07030D	32			R2AA18550R	197
		R2AA04003F	11			R2AA22500L	141
		R2AA04005F	13		Q1AA18750H	428	
		R2AA04010F	15		Q2AA18550H	361	
		R2AA06010F	16		Q2AA18750L	413	
		R2AA06020F	24		Q2AA2211KV	496	
		R2AA08020F	25		R2AA18550H	356	
		RS1□03A	Q1AA06040D		44	R2AA18750H	408
			Q1AA07075D		66	R2AA1811KR	509
			Q2AA07040D		45	Q1EA04003D	16
			Q2AA07050D		62	Q1EA04005D	22
			Q2AA08050D		55	Q1EA04010D	27
			Q2AA13050H		65	Q2EA04006D	21
			R2AA06040F		43	Q2EA04010D	26
	R2AA08040F		40	Q2EA05005D	22		
	R2AA08075F		67	Q2EA05010D	31		
	R2AAB8100H		69	R2EA04003F	16		
	R2AA10075F		64	R2EA04005F	19		
	R2AA13050H		60	R2EA04008F	21		
	R2AA13050D	72	R2EA06010F	25			
	R2AA13120B	76	Q1EA06020D	51			
	RS1□05A	Q1AA10100D	47	Q2EA05020D	43		
		Q1AA10150D	61	Q2EA07020D	49		
		Q1AA12100D	47	R2EA06020F	41		
		Q2AA08075D	43				
		Q2AA08100D	45				
		Q2AA10100H	50				
		Q2AA10150H	62				
		Q2AA13100H	58				
		Q2AA13150H	63				
		R2AAB8075F	37				
		R2AAB8100F	45				
		R2AA10100F	44				
		R2AA13120L	54				
		R2AA13120D	61				
		R2AA13180H	76				
		R2AA13200L	77				
		RS1□10A	Q1AA10200D	111			
			Q1AA10250D	116			
	Q1AA12200D		101				
	Q1AA12300D		123				
	Q1AA13300D		125				
	Q2AA13200H		93				
	Q2AA18200H		101				
R2AA13180D	105						
R2AA13200D	98						
R2AA18350L	142						
R2AA22350L	135						

- Generation of heat built-in regeneration resistance is not included in the numerical value given in the table, it is necessary to add it if needed.
- If external regeneration resistance is used, change the additional items of calorific value of external regeneration resistance as per the place where it is installed.
- Follow the installation method of the “clause 2. for installation”.

■ Pulse output

Outputs 90° phase difference two phase pulse (Phase A, Phase B) and Original pulse (Phase Z) from CN 1-3 to 8.

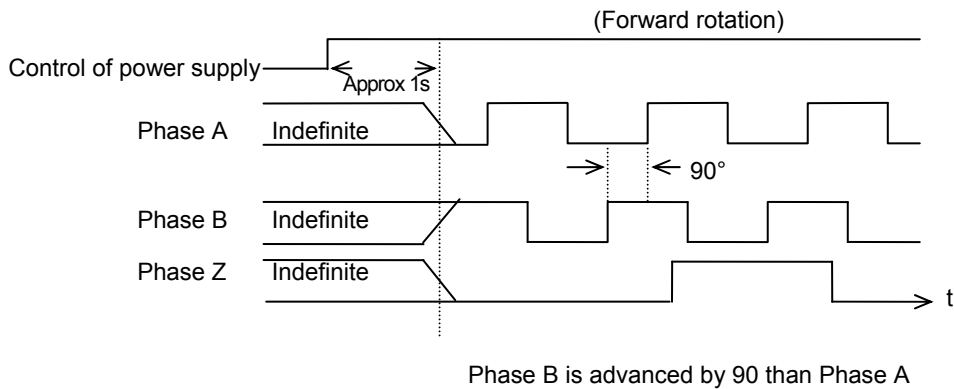

After turning ON the system, the power supply is not fixed for about 1 sec.



If you use absolute encoder, pulse (incremental) output delays for approximately 250 μ s. Moreover 1 pulse is output for every change (once for 1 rotation) of rotations for Phase Z. (Does not decide position relation of Phase Z and Phase A & B. 1 pulse width is output based on leading or trailing edge of Phase A or Phase B)



When other than 1/1 are set as division ratio, Phase A and Phase B are divided but Phase Z is output by original pulse width. In this case, does not set position relation of Phase Z and Phase A & Phase B.

- Serial output (Battery backup method absolute encoder)
 (Absolute encoder without battery)
 (Absolute encoder for incremental system)

Encoder signal output (PS) format can be selected from 3 transmission methods. Select from selection values of [Group C 07 encoder signal output (PS) format]. The specifications are shown below.

Selection values 00: Binary	Binary code output
Transmission method	Asynchronous
Baud rate	9600bps
Transfer frame	8 frames (11 bit / frame)
Transfer format	Refer to page 9-6
Transmission error check	(1 bit) even number parity
Transfer time	9.2ms (Typ.)
Transfer period	Approx.11ms Refer to page 9-10
Increase method	Increase during forward rotation

Selection value 01: Decimal	ASCII in decimal code output
Transmission method	Asynchronous
Baud rate	9600bps
Transfer frame	16 frame (10 bit / frame)
Transfer format	Refer to page 9-7
Transmission error check	(1 bit) even number parity
Transfer time	16.7ms (Typ.)
Transfer period	Approx.40ms Refer to page 9-10
Increase method	Increase during forward rotation

Selection value 02: Encoder_Signal	Encoder signal direct output
Transmission method	Asynchronous
Baud rate	2.5Mbps.4.0Mbps
Transfer frame	3 or4 frame (18 bit / frame)
Transfer format	Refer to page 9-8
Transmission error check	(8 bit)CRC error check
Transfer time	21.6μs or 28.8μs (Typ.) 2.5Mbps 13.5μs or18.0μs (Typ.) 4.0Mbps
Transfer period	125μs Refer to page 9-10
Increase method	Increase when forward rotation



Forward rotation means anticlockwise rotation as seen from motor shaft. Moreover, if absolute value is increased up to maximum, minimum value becomes 0.

9. Specifications

[Serial output]

- Transfer format

Selection value 00: Binary Binary code output

Structure of frame 1

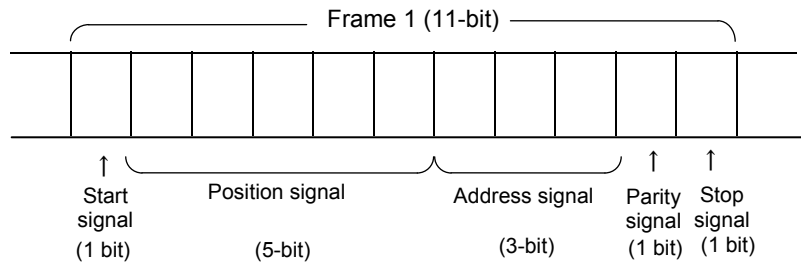

Structure of each frame

	Start signal	Position signal					Address signal			Parity signal	Stop signal
• 1 st frame	0	D0	D1	D2	D3	D4	0	0	0	0/1	1
		(LSB)									
• 2 nd frame	0	D5	D6	D7	D8	D9	1	0	0	0/1	1
• 3 rd frame	0	D10	D11	D12	D13	D14	0	1	0	0/1	1
• 4 th frame	0	D15	D16	0/D17	0/D18	0/D19	1	1	0	0/1	1
• 5 th frame	0	0/D20	0/D21	0/D22	0/D23	0/D24	0	0	1	0/1	1
• 6 th frame	0	0/D25	0/D26	D27	0/D28	0/D29	1	0	1	0/1	1
• 7 th frame	0	0/D30	0/D31	0/D32	0	0	0	1	1	0/1	1
		(MSB)		(MSB)							
• 8 th frame	0	0	0	0	0	0	1	1	1	0/1	1

For PA035C

D0 to D16 ... Absolute value of 1 rotation

D17 to D32 ... Absolute value of many rotations

For RA062C

D0 to D16 ... Absolute value of 1 rotation

D17 to D30 ... Absolute value of many rotations

For PA035S

D0 to D16 ... Absolute value of 1 rotation

9. Specifications

[Serial output]

Selection value 01: Decimal ASCII in decimal code output

Structure of Frame 1

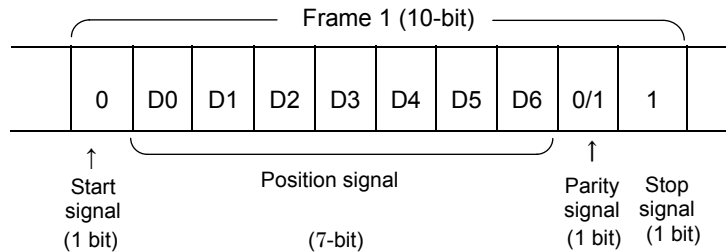

Structure of each Frame

Frame number	Transmission character	Data contents
1	"P" (ASCII code 50H)	Indicates that transmission data is position data
2	","+ " (ASCII code 2BH)	Symbol of multiple rotations data
3	"0" (ASCII code 30H)	Multiple rotations data (5 digits)
4	Highest rank	
5	00000 to 65535 (16383)	
6		
7	Lowest rank	
8	"," (ASCII code 2CH)	End characters
9	"0" (ASCII code 30H)	Absolute value data in 1 rotation (7digits)
10	Highest rank	
11		
12	000000 to 131071	
13		
14		
15	Lowest rank	
16	"CR"(ASCII code 0DH)	Carriage return

For PA035C 1 rotation data :000000 to 131071
 Multiple rotation data :00000 to 65535

For RA062C 1 rotation data :000000 to 131071
 Multiple rotation data :00000 to 16383

For PA035S 1 rotation data :000000 to 131071

9. Specifications

[Serial output]

Selection value 02: Encoder_Signal Encoder signal direct output

Structure of Frame 1

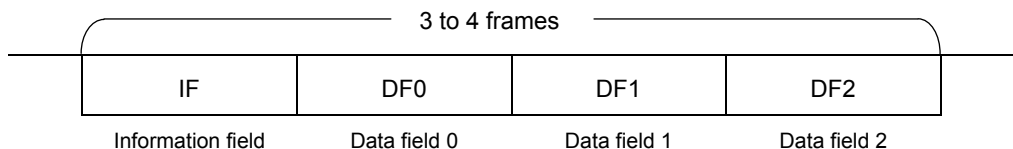

Frame structure

Information field (IF)

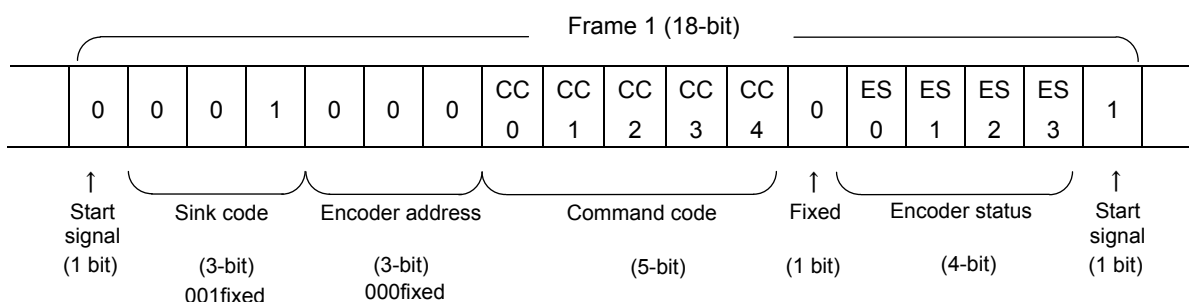

Command code CC [4:0]

CC [4:0]	Command contents
00000	Absolute full data request
00011	Encoder status request
01000	Status clear request
01010	Status+data clear request with multiple rotations Note)

Note) PA035S doesn't have this command.

Encoder status ES [3:0]

ES[3:0]	Status contents
ES0	PA035C Accessing encoder, accessing memory in the encoder
	RA062C Memory operation in the encoder
	PA035S Accessing encoder, accessing memory in the encoder
ES1	PA035C Battery warning
	RA062C "0" fixed
	PA035S "0" fixed
ES2	PA035C Encoder overheat, abnormal memory, overspeed
	RA062C Encoder overheat, abnormal memory, overspeed, abnormal encoder
	PA035S Encoder overheat, abnormal memory, overspeed
ES3	PA035C Battery alarm, single / multiple rotations counter error
	RA062C Multiple rotations counter error
	PA035S single rotation counter error

9. Specifications

[Serial output]

Data field (DF0 to DF2)

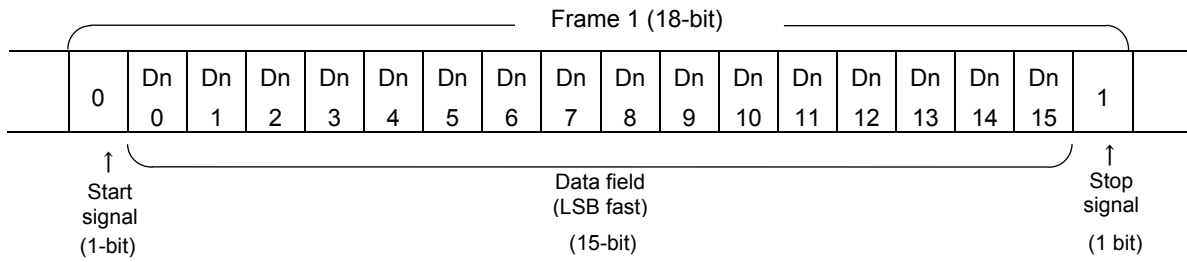

Compatibility table of command and data

Command CC[4:0]	Data			Frame length
	DF0 D0[0:15]	DF1 D1[0:15]	DF2 D2[0:15]	
00000	D0 [0:15]=ABS [0:15]	D1 [0:15]=ABS [16:31]	D2 [0:7]=ABS [32:39] D2 [8:15]=CRC [0:7]	4 frames
00011	D0 [0:15]=ALM [0:15]	D1 [0:7]="00000000"	-	3 frames
01000		D2 [8:15]=CRC [0:7]		
01010 Note)				

Note) PA035S doesn't have this command.

CRC [0: 7] CRC generator polynomial $P(x) = X^8 + X^4 + X^3 + X^2 + 1$
Applicable range is other than start bit and stop bit of each frame

ALM [0: 15] The contents differ as per the types of Encoder.
Check Encoder specifications for details.

9. Specifications

[Serial output]

- Transfer period

Selection value 00: Binary Binary code output

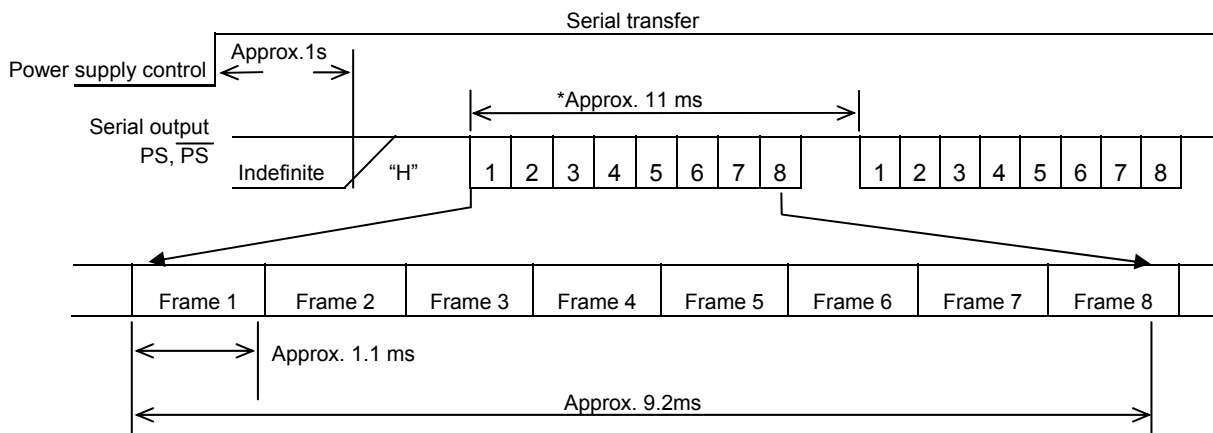

Selection value 01: Decimal 10 ASCII in decimal in decimal code output

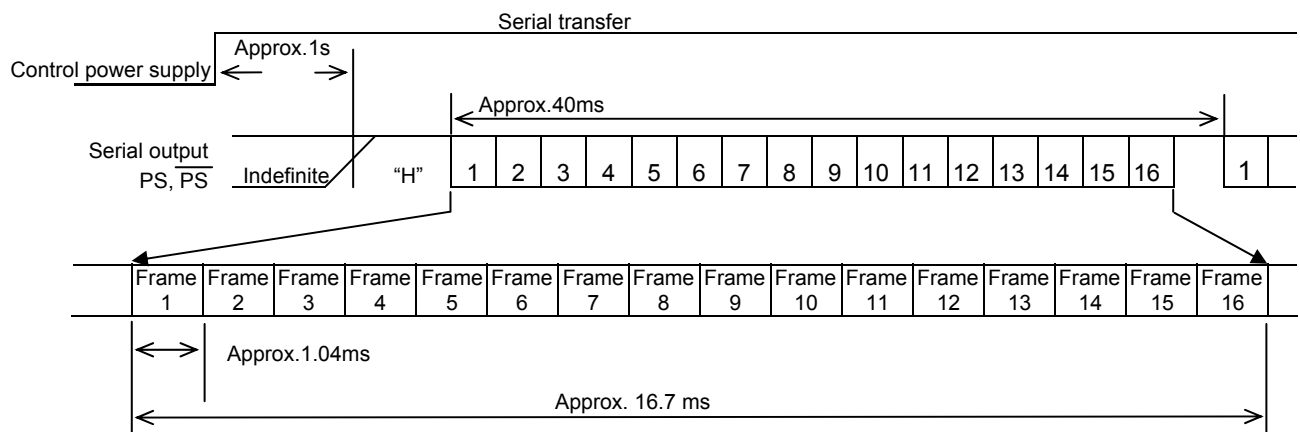

Selection value 02: Encoder_Signal Encoder signal direct output

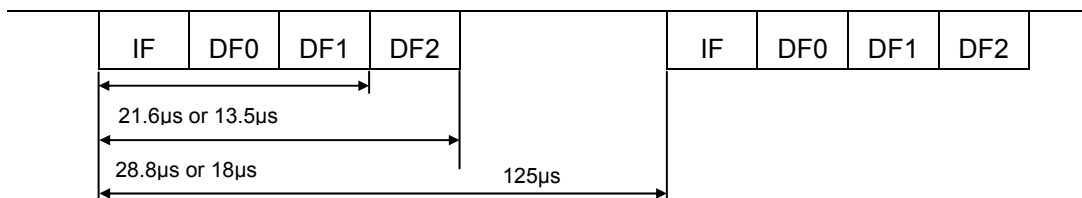

Power supply control is not fixed for 1s after booting. Communication may not necessarily start from the first frame after 1s.

9. Specifications

[Serial output]

- Serial output [Absolute encoder with incremental output]
Encoder signal output (PS) format can be selected from among the three values. Select from among selection values of [Group C 07 Encoder signal output (PS) format].
The specifications are shown below.

Selection value 00: Binary	Binary code output
Transmission method	Asynchronous
Baud rate	9600bps
Transfer frame number	8 frame (11bit/frame)
Transfer format	Refer to page 9-12
Transmission error check	(1bit) even number parity
Transfer time	9.2ms (Typ.)
Transfer period	Approx.11ms Refer to page9-15
Increasing direction	Increase during forward rotation

Selection value 01: Decimal	ASCII in decimal code output
Transmission method	Asynchronous
Baud rate	9600bps
Transfer frame number	16 frame (10 bit/Frame)
Transfer format	Refer to page 9-13
Transmission error check	(1 bit) Even number parity
Transfer time	16.7ms(Typ.)
Transfer period	Approx.40ms Refer to page 9-15
Increasing direction	Increase during forward rotation

Selection value 02: Encoder_Signal	Encoder signal direct output
Transmission method	Manchester encoder synchronous
Baud rate	1Mbps
Transfer frame number	2 frame(25 bit/Frame)
Transfer format	Refer to page 9-14
Transmission error check	(3 bit)CRC error check
Transfer time	66μs (Typ.)
Transfer period	84μs±2μs Refer to page 9-15
Increasing direction	Increase during forward rotation



Forward rotation means anti-clockwise one as seen from motor shaft axis.
When absolute value increases to maximum, it becomes minimum value (0).

9. Specifications

[Serial output]

- Transfer format

Selection value 00: Binary Binary code output

Structure of Frame 1

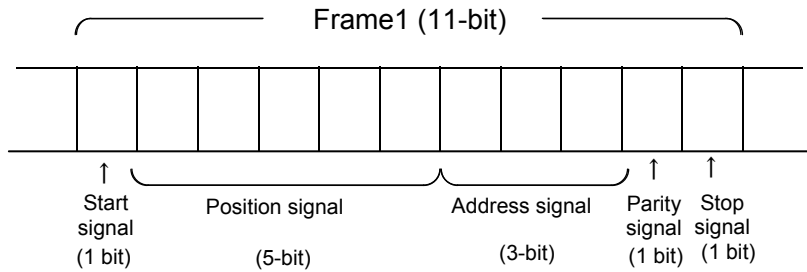

Structure of each frame

	Start signal	Position signal					Address signal			Parity signal	Stop signal
• Frame 1	0	D0	D1	D2	D3	D4	0	0	0	0/1	1
		(LSB)									
• Frame 2	0	D5	D6	D7	D8	D9	1	0	0	0/1	1
• Frame 3	0	D10	D11	D12	D13	D14	0	1	0	0/1	1
• Frame 4	0	D15	D16	D17	D18	D19	1	1	0	0/1	1
• Frame 5	0	D20	D21	D22	D23	BATE	0	0	1	0/1	1
		(MSB)									
• Frame 6	0	SOT	0	WAR	0	0	1	0	1	0/1	1
• Frame 7	0	0	0	0	0	0	0	1	1	0/1	1
• Frame 8	0	0	0	0	0	0	1	1	1	0/1	1

D0 to D10	• • • Absolute value of 1 rotation
D11 to D23	• • • Absolute value of rotations
BATE	• • • Battery alarm
SOT	• • • Absolute value range over
WAR	• • • Battery warning

9. Specifications

[Serial output]

Selection value 01: Decimal ASCII in decimal code output

Structure of frame 1

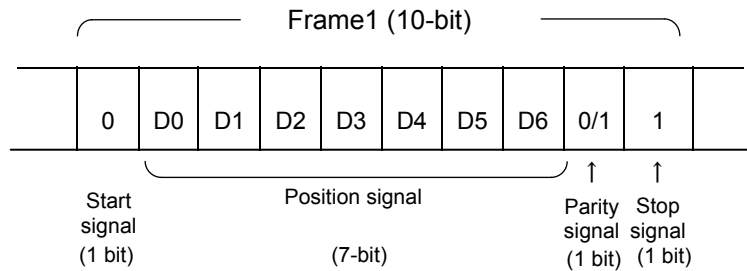

Structure of each frame

Frame number	Transmission character	Data contents
1	"P" (ASCII code 50H)	Indicates that transmission data is a position data
2	"+" (ASCII code 2BH)	Code of multiple rotations
3	"0" (ASCII code 30H)	Multiple rotations data (5 digits)
4	Highest rank	
5	0000 to 8191	
6		
7	Lowest rank	
8	"," (ASCII code 2CH)	End character
9	"0" (ASCII code 30H)	Absolute value data in 1 rotation (7 digits)
10	Highest rank	
11		
12	0000 to 2047	
13		
14		
15	Lowest rank	
16	"CR" (ASCII code 0DH)	Carriage return

9. Specifications

[Serial output]

Selection value 02: Encoder_Signal Encoder signal direct output

(Synchronous Manchester encoding)

Structure of Frame 1

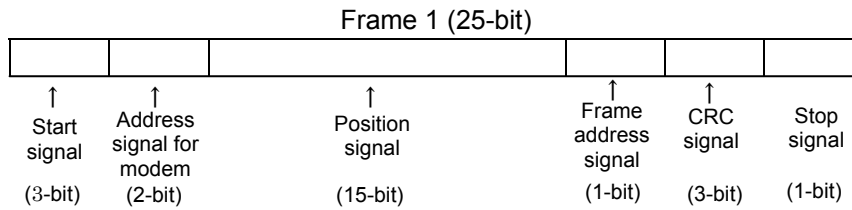

First 2 bits of start signal are output as signal of all bit section H (1). All the remaining 23 bits after this are Manchester encoded.

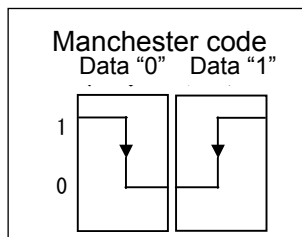

Generator polynomial of CRC signal is $P(X) = X^3 + X + 1$.

Structure of each frame

• 1st frame

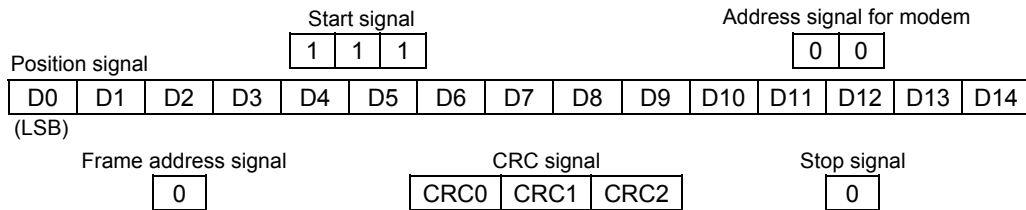

• 2nd frame

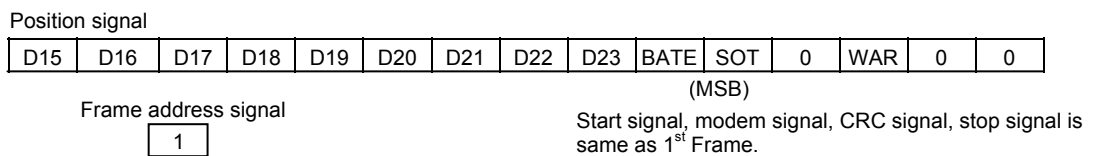

D0 to D10	··· 1 rotation absolute value
D11 to D23	··· Multi rotation absolute value
BATE	··· Battery alarm
SOT	··· Absolute value range over
WAR	··· Battery warning

9. Specifications

[Serial output]

- Transfer period

Selection value 00: Binary Binary code output

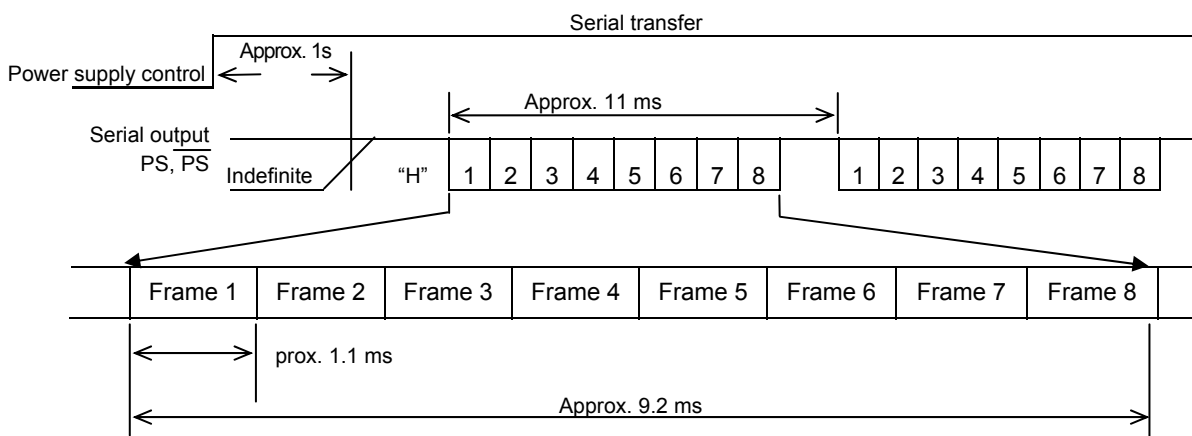

Selection value 01: Decimal Decimal ASCII code output

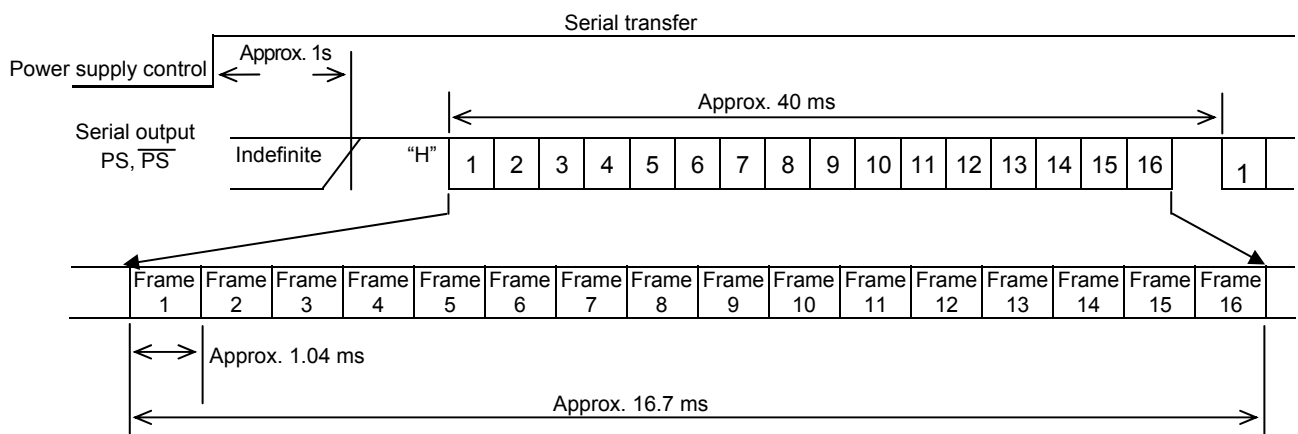

Selection value 02: Encoder_Signal Encoder signal direct output

(Synchronous Manchester encoding)

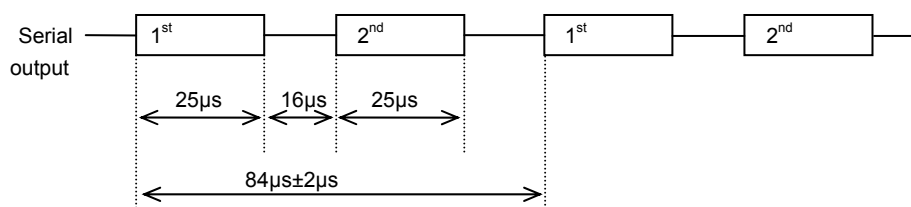

Power supply control is uncertain for 1s after booting.
Communication may not necessarily start from 1st frame after 1s.

9. Specifications

[Serial output]

■ Serial output [Request method absolute encoder]

Encoder signal output (PS) format can be selected from among these three values. Select from among the values of [Group C 07Encoder signal output (PS) format]. The specifications are shown below.

Selection value 00: Binary	Binary code output
Transmission method	Asynchronous
Baud rate	9600 bps
Number of frames transferred	8 Frames (11 bit/frame)
Transfer format	Refer to page 9-17
Transmission error check	(1 bit) even number parity
Transfer time	9.2 ms (type.)
Transfer period	Approx. 11ms Refer to page 9-20
Increase direction	Increase during forward rotation

Selection value 01: Decimal	Decimal ASCII code output
Transmission method	Asynchronous
Baud rate	9600 bps
Number of frames transferred	16 frame (0 bit/ frame)
Transfer format	Refer to page 9-18
Transmission error check	(1 bit) even number parity
Transfer time	16.7 ms (Type.)
Transfer period	Approx. 40ms Refer to page 9-20
Increase direction	Increase during forward rotation

Selection value 02: Encoder_Signal	Encoder signal direct output
Transmission method	Synchronous Manchester encoding
Baud rate	1Mbps
Number of frames transferred	2 frame (27 bit/frame)
Transfer format	Refer to page 9-19
Transmission error check	(3 bit) CRC error check
Transfer time	66μs (Typ.)
Transfer period	125μs±2μs Refer to page 9-20
Increase direction	Increase during forward rotation



Forward rotation means anti-clockwise one as seen from motor shaft axis.
When absolute value increases to maximum, it becomes minimum value (0).

9. Specifications

[Serial output]

- Transfer format

Selection value 00: Binary Binary code output

Structure of Frame 1

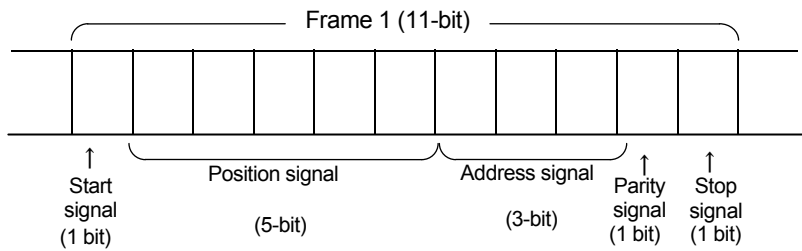

Structure of each frame

	Start signal	Position signal					Address signal			Parity signal	Stop signal
· Frame 1	0	D0	D1	D2	D3	D4	0	0	0	0/1	1
		(LSB)									
· Frame 2	0	D5	D6	D7	D8	D9	1	0	0	0/1	1
· Frame 3	0	D10	D11	D12	D13	D14	0	1	0	0/1	1
· Frame 4	0	D15	D16	D17	D18	D19	1	1	0	0/1	1
· Frame 5	0	D20	D21	D22	D23	D24	0	0	1	0/1	1
· Frame 6	0	D25	0/D26	0/D27	AW0	AW1	1	0	1	0/1	1
		(MSB)		(MSB)							
· Frame 7	0	0	0	0	0	0	0	1	1	0/1	1
· Frame 8	0	0	0	0	0	0	1	1	1	0/1	1

D0 to D14 . . . Absolute value of 1 rotation

D15 to D27 . . . Absolute value of rotations

AW0	AW1	Contents
0	0	Normal
0	1	Encoder failure
1	1	Position data trouble
Output LOW		Encoder error

9. Specifications

[Serial output]

Selection value 01: Decimal Decimal ASCII code output

Structure of frame 1

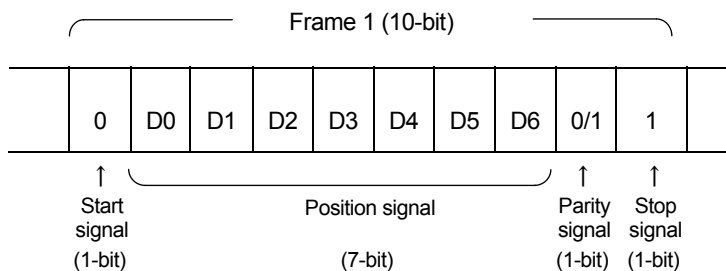

Structure of each frame

Frame No.	Transmission character	Data contents
1	"P" (ASCII code 50H)	Shows that transmission data is position data.
2	"+" (ASCII code 2BH)	Code for data with multiple rotations
3	"0" (ASCII code 30H)	Multiple rotations Data (5digits)
4	Highest rank	
5	0000 to 8191	
6		
7	Lowest rank	
8	"," (ASCII code 2CH)	Delimiter
9	"0" (ASCII code 30H)	Absolute data value in 1 rotation (7 digits)
10	Highest rank	
11		
12	0000 to 2047	
13		
14		
15	Lowest rank	
16	"CR"(ASCII code 0DH)	Carriage return

1 rotation data : 0000 to 32767

Rotations : 0000 to 8191

9. Specifications

[Serial output]

Selection code 02: Encoder_Signal Encoder signal direct output

(Synchronous Manchester encoding)

Structure of Frame 1

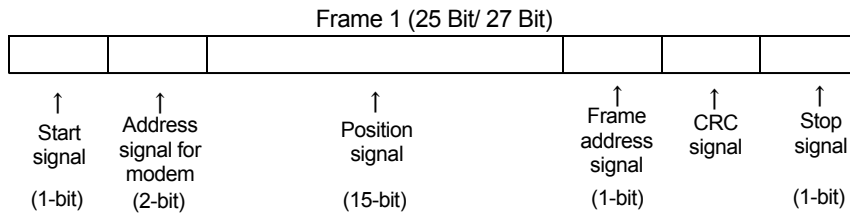

The first 2 bits of start signal is output as the signal of the whole bit interval H (1). The subsequent 23 bits are put into Manchester encoding.

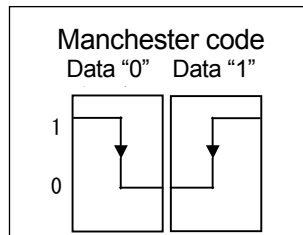

Generator polynomial of CRC signal is $P(X)=X^3+X+1$.

Structure of each frame

• 1st frame

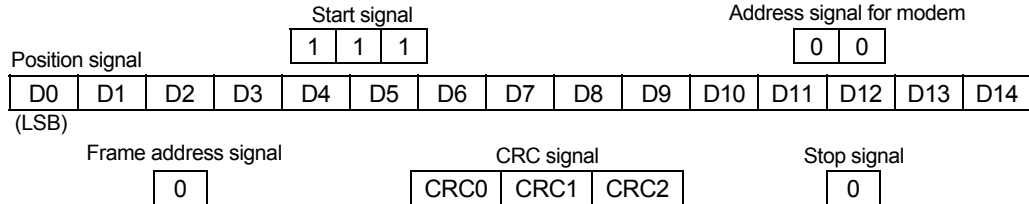

• 2nd frame

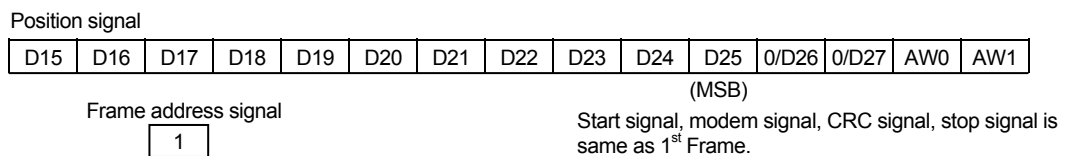

D0 to D14 ... Absolute value of 1 rotation

D15 to D27 ... Absolute value of rotations

AW0	AW1	Contents
0	0	Normal
0	1	Encoder failure
1	1	Position data trouble
Output LOW		Encoder error

9. Specifications

[Serial output]

- Transfer period

Selection value 00: Binary Binary code output

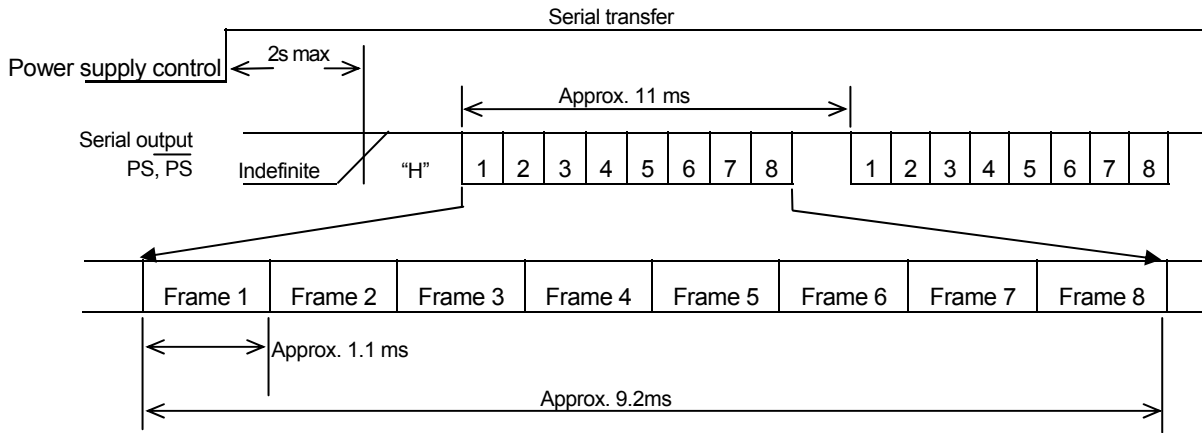

Selection value 01: Decimal Decimal ASCII code output

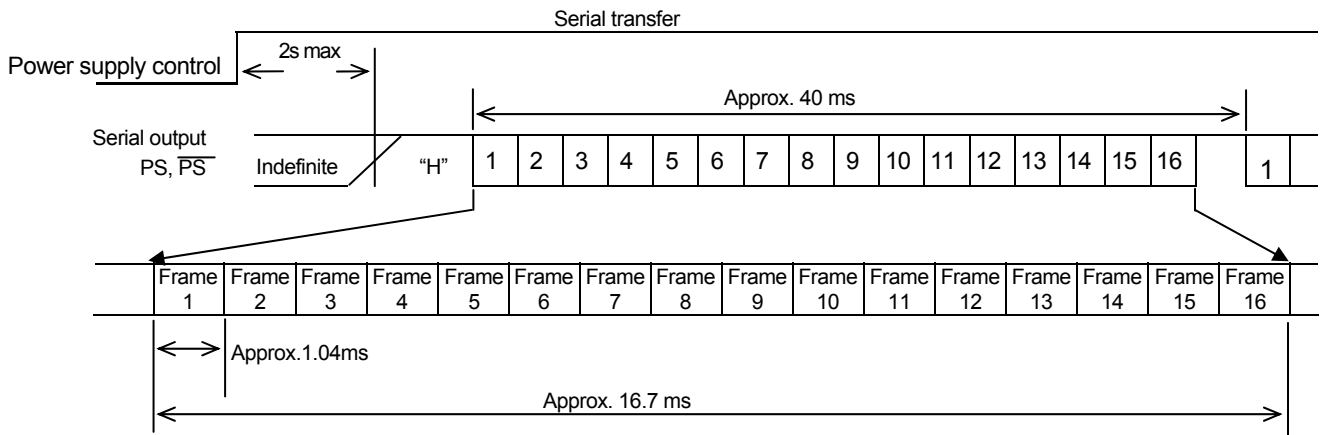

Selection value 02: Encoder Signal Encoder signal direct output

(Synchronous Manchester encoding)

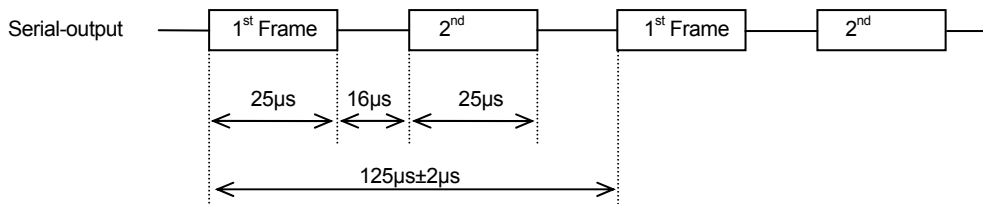

Power supply control is uncertain for 2s or less after booting. Communication may not necessarily start from 1st frame after 2s.

9. Specifications

[Serial output]

Serial output [Wire-saving incremental encoder]

While using incremental encoder, output actual position monitor value, irrespective of setting value of parameter Group C 07 encoder signal output (PS) format.

When using wire-saving incremental encoder	
Selection value : invalid	---
Transmission method	Asynchronous
Baud rate	9600bps
Number of transferred frames	8 frames (11bit/frame)
Transfer format	Chart below
Transmission error check	(1-bit) Even number parity
Transfer time	9.2ms (Type.)
Transfer period	Apprx.11ms Refer to page9-22
Increasing direction	Increasing at normal rotation

 Normal rotation means anticlockwise one as seen from motor shaft axis. Absolute value will be minimum value (0) if it increases to maximum.

Transfer format

Structure of Frame 1

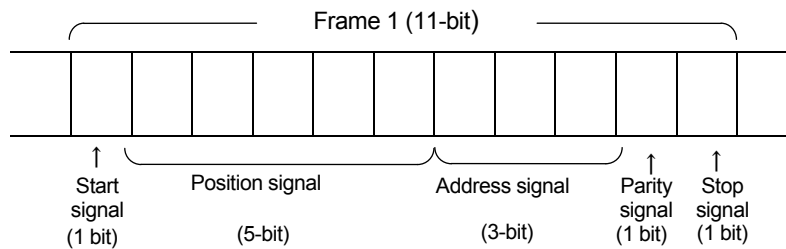

Structure of each frame

	Start signal	Position signal					Address signal			Parity signal	Stop signal
·Frame 1	0	D0	D1	D2	D3	D4	0	0	0	0/1	1
		(LSB)									
·Frame 2	0	D5	D6	D7	D8	D9	1	0	0	0/1	1
·Frame 3	0	D10	D11	D12	D13	D14	0	1	0	0/1	1
·Frame 4	0	D15	D16	D17	D18	D19	1	1	0	0/1	1
·Frame 5	0	D20	D21	D22	D23	D24	0	0	1	0/1	1
·Frame 6	0	D25	D26	D27	D28	D29	1	0	1	0/1	1
·Frame 7	0	D30	D31	0	0	0	0	1	1	0/1	1
		(MSB)									
·Frame 8	0	0	0	0	0	0	1	1	1	0/1	1

9. Specifications

[Serial output]

- Transfer cycle

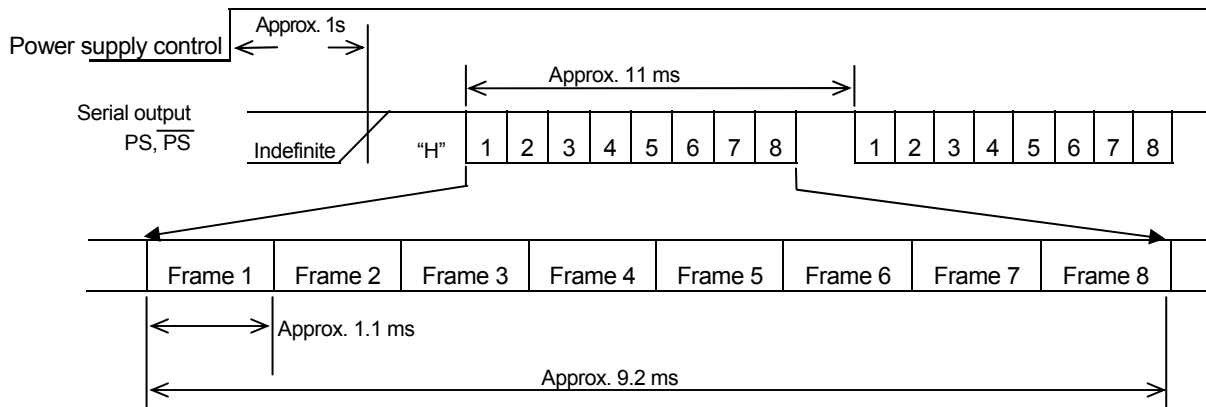

9. Specifications

[Servo motor]

■ Servo motor general specifications

Series Name	Q1	Q2	R2
Time Rating	Continuous		
Insulation Classification	Type F		
Dielectric Strength Voltage	AC1500V 1 minute		
Insulation Resistance	DC500V, more than 10MΩ		
Protection Method	Fully closed, Auto cooling		
	IP67 (However, Q1□A04,06 and 07 is IP40) It conforms to IP67 by using a waterproof connector, conduit, shell, clamp, etc.	IP67 (However, Q2□A04 is IP40)	IP67 (Excluding shaft passages and cable ends. R2AA13 is IP65)
Sealing	Sealed(except Q1□A04,06,07)	Sealing (Except Q2□A04)	Not sealed (Optional)
Ambient Temperature	0 to +40°C		
Storage Temperature	-20 to +65°C		
Ambient Humidity	20 to 90% (Without condensation)		
Vibration Classification	V15		
Coating Color	Munsell N1.5 equivalent		
Excitation Method	Permanent-magnet type		
Installation Method	Flange mounting		

■ Rotation Direction Specifications

- When a command to increase the position command is entered, the servo motor rotates in a counterclockwise direction from the load side

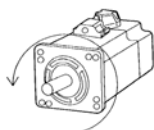

- Encoder Signal Phases

Incremental encoder

<Normal rotation>

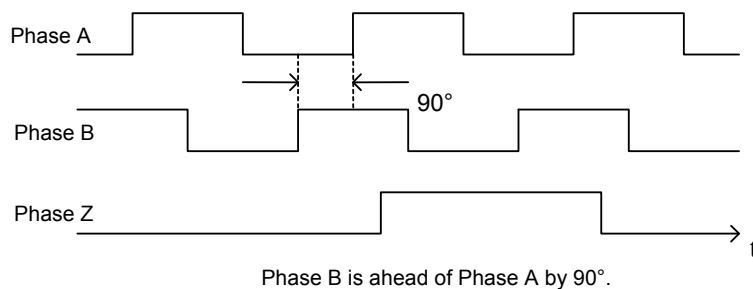

<Reverse rotation>

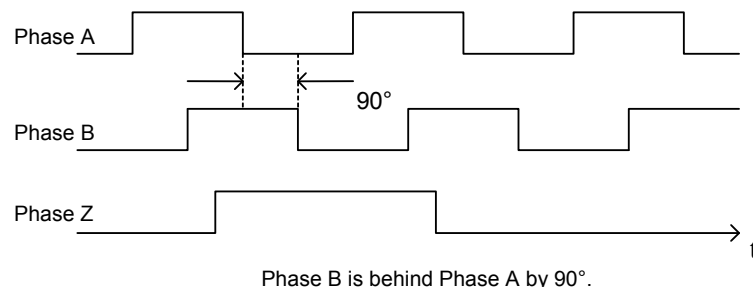

When the Z-Phase is high, both A- and B- Phases cross the low level, once every revolution.

Absolute encoder

Normal (forward) rotation: Position data incremental output

Reverse rotation: Position data decreased output

9. Specifications [Mechanical specifications of servo motor]

■ Mechanical specifications

● Vibration Resistance

Install the servo motor in a horizontal direction (as shown in the following figure), so that when vibration is applied in any 3 directions (up/down, back/forward, left/right) it can withstand the vibration acceleration up to 24.5m/s^2 .

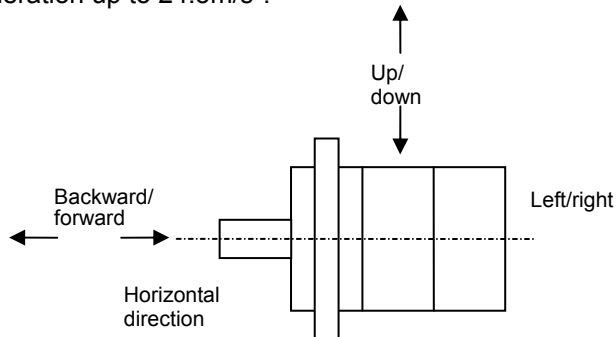

● Shock Resistance

Install the shaft of the servo motor in a horizontal direction (as shown in the following figure). It should withstand shock acceleration up to 98m/s^2 (when shocks are applied in an Up/down direction) for 2 times. However, since a precision detector is fixed to the counter-load side of the motor, any shock applied to the shaft may cause damage the detector; therefore, do not subject the shaft to shock under any circumstances.

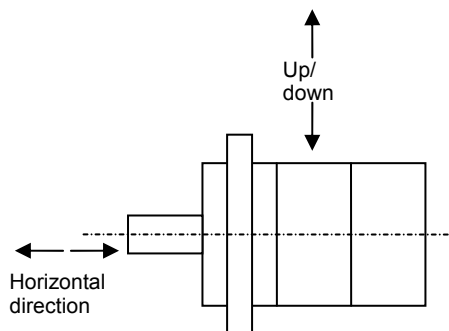

● Working accuracy

The following table shows the accuracy of the servo motor output shaft and precision (Total Indicator Reading) of the parts surrounding the shaft.

Items	* 1 T.I.R.	Reference Figure
Vibrations of output shaft terminal α	0.02	
Eccentricity of the external diameter of the flange on output shaft M (β)	0.06 (Below $\square 86$)	
	0.08 (Above $\square 100$)	
Perpendicularity of the flange face to output shaft M (γ)	0.07 (Below $\square 86$)	
	0.08 (Above $\square 100$)	

*1 T.I.R (Total Indicator Reading)

9. Specifications [Mechanical specifications of servo motor]

- **Vibration Classification**

The vibration classification of the servo motor is V15 or less, at the maximum rotation speed for a single servo motor unit, and is measured in the manner pictured below.

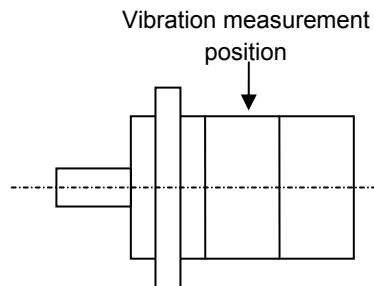

- **Mechanical Strength**

The output strength of the servo motor can withstand peak torque at stall.

- **Oil seal**

A Type S oil seal (as described in the following table) is fixed to the output shaft of the servo motor. This oil seal is produced by NOK Corporation; please contact your dealer or sales representative for replacement of the oil seal.

Servo Motor Model	Oil Seal type (Type S)	Servo Motor Model	Oil Seal type (Type S)
Q1□A04○○○□	N/A	Q2AA22○○○□	AC2368E0
Q1□A06○○○□		Q2AA22550□	AC3152E0
Q1AA07○○○□		Q2AA22700□	AC3152E0
Q1AA10○○○□	Q2AA2211K□		
Q1AA12○○○□	Q2AA2215K□		
Q1AA13○○○□	AC1677E1	R2□A04○○○□	N/A (Optional)
Q1AA18450□	AC2368E0	R2□A06○○○□	
Q1AA18750□	AC2651A8	R2AA□8○○○□	
Q2□A04○○○□	N/A	R2AA10○○○□	N/A (Optional)
Q2□A05○○○□	AC0382A0	R2AA13○○○□	AZ1677E0
Q2□A07○○○□	AC0687A0	R2AA18350□	AC2368E0
Q2AA08○○○□	AC0875A0	R2AA18450□	
Q2AA10○○○□	AC1306E0	R2AA18550□	AC2651A8
Q2AA13○○○□	AC1677E1	R2AA18750□	
Q2AA18○○○□	AC2368E0	R2AA1811K□	
Q2AA18550□	AC2651A8	R2AA22○○○□	RZ2368E0
Q2AA18750□		R2AA22○○○□	

- **Degree of decrease rating: R2AA Motor fixed oil seal and brake**

About oil seal and brake fixed, considering of a rise in heat, continuous zone should apply the following degree of decrease rating.

Brake \ Oil seal	non-fixed oil seal	fixed oil seal
	with no brake	No decrease rating
with brake	decrease rating 1	decrease rating 2

Decrease rating 1	Servo Motor Model R2AA	04010F	06040F
	degree of decrease rating %	90	

Decrease rating 2	Servo Motor Model R2AA	04005F	04010F	06040F	08075F
	degree of decrease rating %	90	85	80	90

9. Specifications

[Holding brake specifications]

■ Holding brake specifications

An optional holding brake is available for each motor. Since this brake is used for holding, it cannot be used for braking, except for an emergency. Turn brake excitation ON or OFF by using the holding brake timing signal output.

When using this signal, set the command for brake release time to 0min^{-1} for the servo amplifier.

To externally control the holding brake, a response time (as shown in the following table) is required.

When using a motor with a brake, determine a time sequence that takes this delay time into account.

	Model	Static friction torque N.m	Release time msec	Braking delay time msec	
				Varistor	Diode
Q1	Q1AA04003D	0.098	25	15	100
	Q1AA04005D	0.157			
	Q1AA04010D	0.320			
	Q1AA06020D	0.637	30	20	120
	Q1AA06040D	1.274			
	Q1AA07075D	2.38	40	20	200
	Q1AA10100D	3.92	40	30	120
	Q1AA10150D	7.84	100	30	140
	Q1AA10200D	7.84			
	Q1AA10250D	9.80	100	30	140
	Q1AA12100D	3.92	100	30	140
	Q1AA12200D	7.84	100	30	140
	Q1AA12300D	11.8	100	30	140
	Q1AA13400D	19.6	120	50	150
	Q1AA13500D	19.6			
Q1AA18450M	32.0	150	40	250	
Q1AA18750H	54.9	300	140	400	
Q2	Q2AA04006D	0.191	25	15	100
	Q2AA04010D	0.319			
	Q2AA05005D	0.167	15	10	100
	Q2AA05010D	0.353			
	Q2AA05020D	0.353			
	Q2AA07020D	0.69	25	15	100
	Q2AA07030D	0.98			
	Q2AA07040D	1.372			
	Q2AA07050D	1.85	30	20	200
	Q2AA08050D	1.96	30	20	200
	Q2AA08075D	2.94			
	Q2AA08100D	2.94			
	Q2AA10100H	3.92	40	30	120
	Q2AA10150H	7.84	100	30	140
	Q2AA13050H	3.50	40	30	120
	Q2AA13100H	9.0	70	30	130
	Q2AA13150H	9.0	100	30	140
	Q2AA13200H	12.0			
	Q2AA18200H	12.0	100	30	140
	Q2AA18350H	32.0	120	40	150
	Q2AA18450H	32.0	150	40	250
	Q2AA18550R	54.9	300	140	400
	Q2AA18550H				
	Q2AA18750L				
	Q2AA22550B	90.0	300	140	400
	Q2AA22700S	90.0	300	140	400
	Q2AA2211KV				
Q2AA2215KV					

9. Specifications

[Holding brake specifications]

Model	Static friction torque N.m	Release time msec	Braking delay time msec		
			Varistor	Varistor	
Q1	Q1EA04003D	0.098	25	15	100
	Q1EA04005D	0.157			
	Q1EA04010D	0.32			
	Q1EA06020D	0.637			
Q2	Q2EA04006D	0.191	25	15	100
	Q2EA04010D	0.319			
	Q2EA05005D	0.167			
	Q2EA05010D	0.353			
	Q2EA05020D	0.353			
R2	Q2EA07020D	0.69	25	15	100
	R2AA04003F	0.32			
	R2AA04005F	0.32			
	R2AA04010F	0.32			
	R2AA06010F	0.36			
	R2AA06020F	1.37			
	R2AA08020F	2.55			
	R2AA06040F	1.37			
	R2AA08040F	2.55			
	R2AA08075F	2.55			
	R2AAB8075F	3.92			
	R2AAB8100H	3.92			
	R2AAB8100F	3.92			
	R2AA10075F	3.92			
	R2AA10100F	3.92			
	R2AA13050□	3.50			
	R2AA13120□	9.0			
	R2AA13180□	9.0			
	R2AA13200□	12.0			
	R2AA18350□	22			
	R2AA18450H	32			
	R2AA18550□	42			
	R2AA18750H	54.9			
	R2AA1811KR	100			
	R2AA22350L	32			
	R2AA22500L	42			
	R2EA04003F	0.32			
	R2EA04005F	0.32			
	R2EA04008F	0.32			
	R2EA06010F	0.36			
	R2EA06020F	1.37			

Brake operating time is measured in the following circuit.

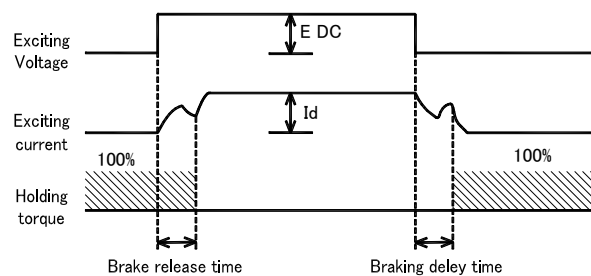
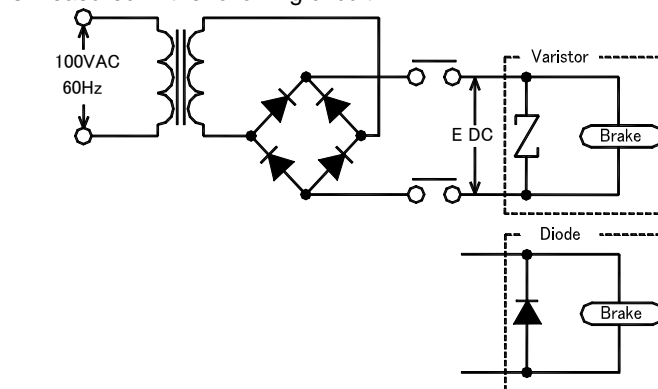

The brake release time and braking delay time refer to those mentioned in the above tables. The brake release time is the same for both the varistor and diode.

Materials

[Selection Details]

◆ Acceleration time / Moderation time / Allowable repetition frequency	1
◆ Loading Precautions	3
◆ Attention to average rotational speed	3
◆ Dynamic Brake	4
◆ Regenerative treatment / Regenerative electric power calculation / Confirmation of regenerative electric power	7
◆ External regenerative resistor / Dimension	11

[International Standards]

◆ International standard conformity · Certificate number	18
◆ Compliance with E C directives · Recommended prevention components ·	20

[Dimension]

◆ Servo amplifier	24
◆ Servo motor	30

[Servo Motor Data Sheet]

◆ Characteristics table	41
◆ Velocity – Torque characteristics	47
◆ Over load characteristics	56

[Option]

◆ Connector / Communication cable	65
◆ Metal mounting fittings	66
◆ Monitor box	69
◆ Lithium battery / EMC kit	70

[Encoder Clear]

◆ Clear / Reset method	71
----------------------------------	----

[Electronic Gear]

◆ Usage	72
-------------------	----

[Shortened Model Number]

◆ Set-up contents	73
-----------------------------	----

Materials: Selection details

Time of acceleration and deceleration/permitted repetition

Time of Acceleration and Deceleration

- The motor's acceleration time (t_a) and deceleration time (t_b) when under a constant load is calculated by following method.

$$\text{Acceleration time: } t_a = (J_M + J_L) \cdot (2\pi / 60) \cdot \{(N_2 - N_1) / (T_P - T_L)\} \text{ [S]}$$

$$\text{Deceleration time: } t_b = (J_M + J_L) \cdot (2\pi / 60) \cdot \{(N_2 - N_1) / (T_P + T_L)\} \text{ [S]}$$

- These expressions are for the rated speed values, but exclude the viscous torque and friction torque of the motor.

t_a : Acceleration time(S)

T_P : Instantaneous maximum stall torque (N·m)

t_b : Deceleration time(S)

T_L : Load torque (N·m)

J_M : Motor inertia ($\text{kg} \cdot \text{m}^2$)

J_L : Load inertia ($\text{kg} \cdot \text{m}^2$)

N_1, N_2 : Rotational speed of motor (min^{-1})

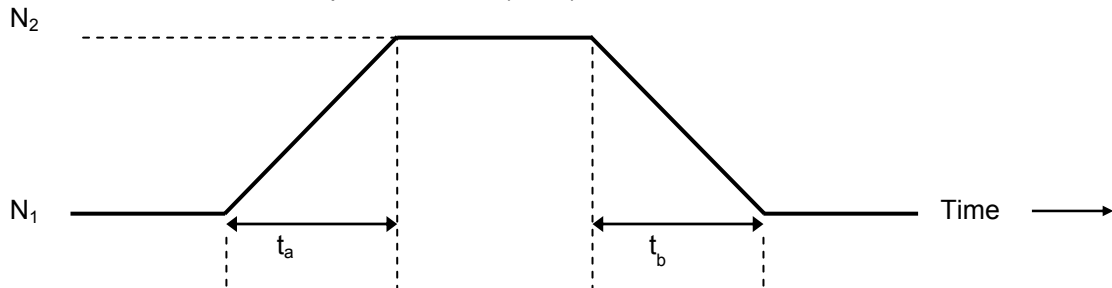

- When determining t_a and t_b , it is recommended to do so by calculating the load margin and decreasing the instantaneous maximum instant stall torque value (T_P) to 80%.

Permitted repetitions

- There are separate limitations on repetitive operations for both the servo motor and servo amplifier, and the conditions of both must be fulfilled simultaneously.

Permitted repetitions for the servo amplifier

When START / STOP sequences are repeated frequently, confirm in advance that they are within the allowed range. Allowed repetitions differ depending on the type, capacity, load inertia, adjustable-speed current value and motor rotation speed of the motor in use. If the load inertia = motor inertia $\times m$ times, and when the permitted START/ STOP repetitions (up until the maximum rotation speed) exceed $\frac{20}{m+1}$ times/min, contact your dealer or sales office for assistance, as precise calculation of effective torque and regenerating power is critical.

Permitted repetitions for the motor

Permitted START/ STOP repetitions differ according to the motor's usage conditions, such as the load condition and time of operation.

When continuous-speed status and motor stop status is repeated

- In operating conditions such as those shown below, and the motor should be used at a frequency in which its effective torque is less than the rated torque (T_R).

Materials Selection details

[Permitted repetition/ loading precaution/ attention to average rotational speed]

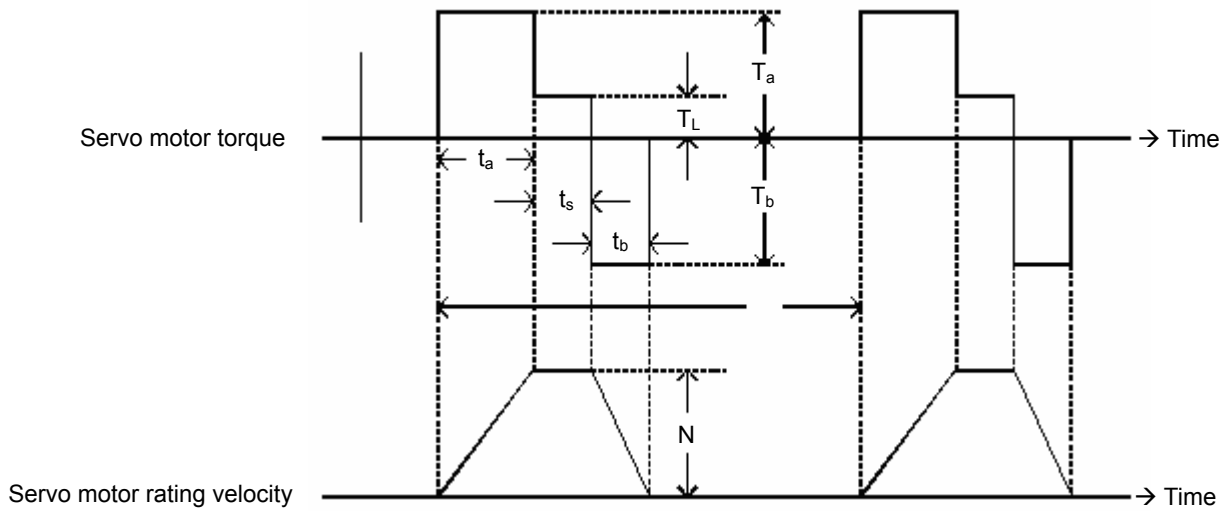

If the operating cycle is considered as 't', the usable range can be determined as follows:

$$t \geq \frac{T_a^2 t_a + T_L^2 t_s + T_b^2 t_b}{T_R^2} \text{ [s]}$$

- T_a : Acceleration torque
- T_b : Deceleration torque
- T_L : Load torque
- T_{rms} : Effective torque
- T_R : Rated torque

When cycle time (t) is predetermined, T_a, T_b, t_a, t_b appropriate in the above formula are required.

- ✍ When actually determining the system drive mode, it is recommended to calculate the load margin and suppress it to $T_{rms} \leq 0.7T_R$
- When the motor repeats acceleration, deceleration, and stop status
 - For the operating status shown below, the value of permitted repetitions n (times/min) is displayed by following equation.

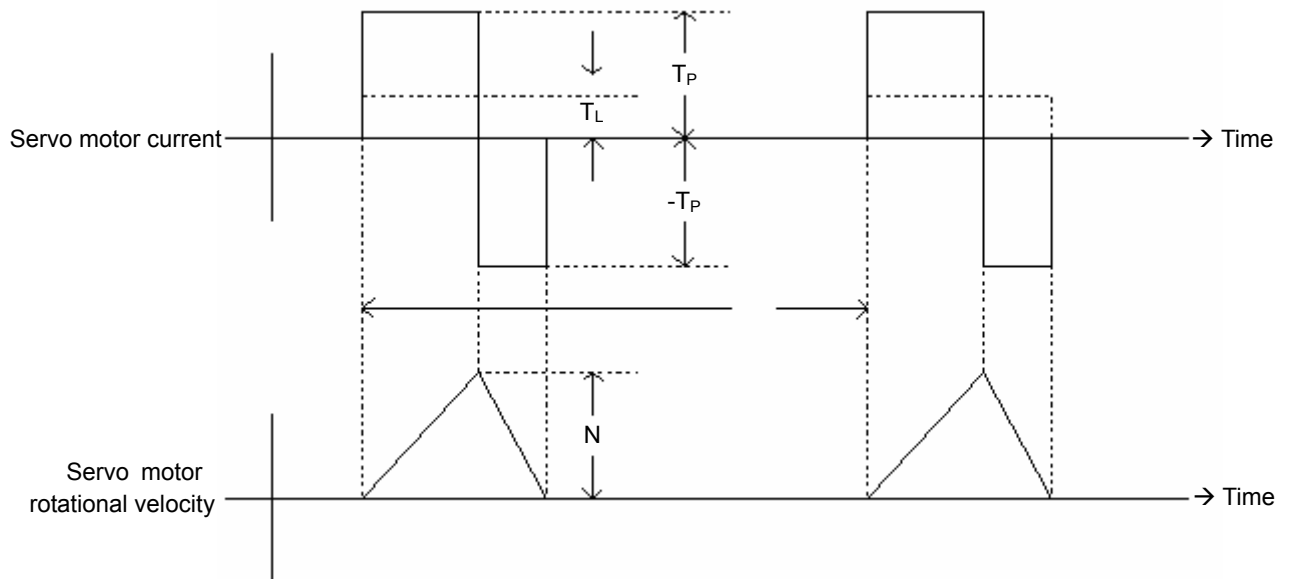

$$n = 2.86 \times 10^2 \times \frac{1}{N (J_m + J_L)} \times \frac{T_P^2 - T_L^2}{T_P^3} \times T_R^2 \text{ [times/ min]}$$

T_R : Rated torque

Materials Selection details

[Permitted repetition/ loading precaution/ attention to average rotational speed]

■ When the motor repeats acceleration, constant speed operation, and deceleration status

- For the operating status shown below, the value of permitted repetitions 'n' (times/min) is displayed by following equation.

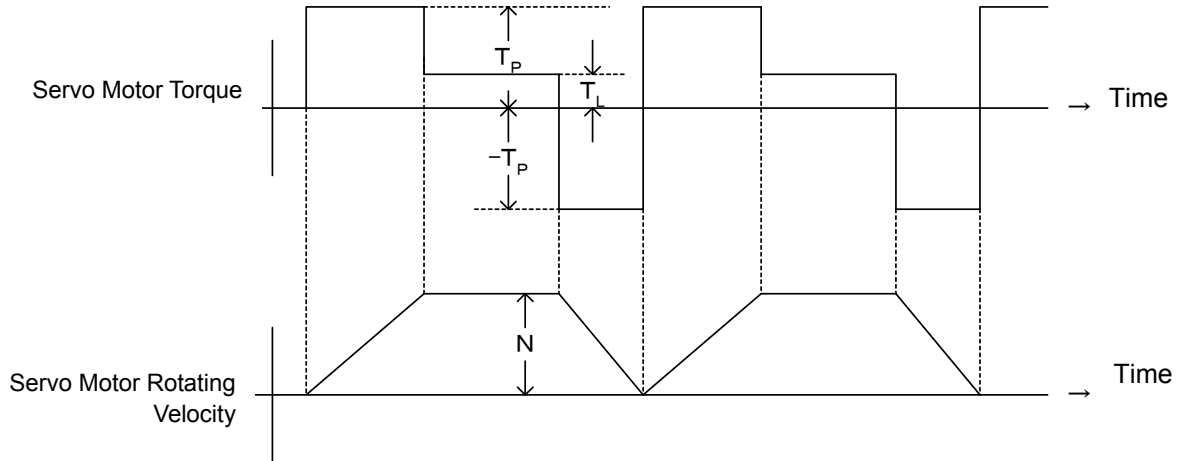

$$n = 2.86 \times 10^2 \times \frac{1}{N (J_m + J_L)} \times \frac{T_R^2 - T_L^2}{T_P} \text{ [times/ min]}$$

■ Loading precautions

● Negative load

The servo amplifier cannot perform continuous operations by negative load from the servo motor for more than several seconds.

When using the amplifier with a negative load, contact your dealer or sales representative.

- Downward motor drive (when there is no counter weight.)
- When using like a generator, such as the wind-out spindle of a winder.

● Load Inertia (J_L)

When the servo amplifier is used with a load inertia exceeding the allowable load inertia calculated in terms of the motor shaft, a main circuit power overvoltage detection or regenerative error function may be issued at the time of deceleration.

The following measures must be taken in this case. For more details, please consult with your dealer or sales representative.

- Reduce the torque limit
- Extend the acceleration and deceleration time (Slow down)
- Reduce the maximum motor speed
- Install an external regenerative resistor

● Attention to average rotational speed

Please use the average rotational speed of the motor below the maximum rotational speed of the continuous zone.

(Application motor : R2AA13050D, R2AA13120D, R2AA13180D, R2AA13200D, R2AA22350L, R2AA18350D, R2AA18450H, R2AA22500L, R2AA1811KR)

- Slowing down the revolution angle by the dynamic brake
 - Slowing down the revolution angle by the dynamic brake is as follows:

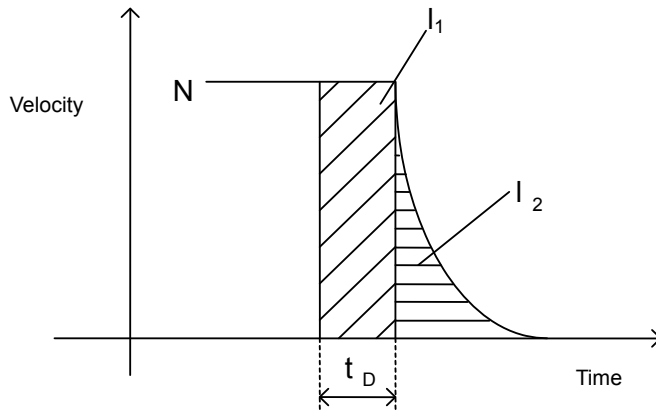

N: Motor speed (min^{-1})
 I_1 : Slow-down revolution angle (rad) by amplifier internal process time t_D .
 I_2 : Slow-down revolution angle (rad) by on dynamic brake operation
 t_D : Delay time from signal display to operation start (s)
 (Depending on amplifier capacity; Refer to following)

Servo Amplifier Model Name	Delay Time t_D (S)
RS1□01 □=L/A/N/E	10×10^{-3}
RS1□03 □=L/A/N/E	10×10^{-3}
RS1□05 □=A/L	10×10^{-3}
RS1□10 □=A/L	24×10^{-3}
RS1□15 □=A/L	24×10^{-3}
RS1A30	42×10^{-3}

[Standard formula] When load torque (T_L) is considered as zero.

$$I = I_1 + I_2$$

$$= \frac{2 \pi N \cdot t_D}{60} + (J_M + J_L) \times (\alpha N + \beta N^3)$$

- I : Integrated slow-down rotation angle (rad)
- J_m : Motor inertia ($\text{kg} \cdot \text{m}^2$)
- J_L : Load inertia (Motor axis conversion) ($\text{kg} \cdot \text{m}^2$)
- $\alpha \cdot \beta$: Refer to the constant table of the dynamic brake

■ Instantaneous tolerance of dynamic brake

- If the load inertia (J_L) substantially exceeds the applicable load inertia, abnormal heat can be generated due to dynamic brake resistance. Take precautions against situations such as an overheat alarm or the failure of dynamic break resistance, and consult your dealer or sales representative if such a situation occurs.

The energy (E_{RD}) consumed by dynamic brake resistance in 1 dynamic brake operation is as follows:

$$E_{RD} = \frac{2.5}{R\phi + 2.5} \times \left\{ \frac{1}{2} (J_M + J_L) \times \left(\frac{2\pi}{60} N \right)^2 - I \times T_L \right\}$$

$R\phi$: Motor phase winding resistance (Ω)

J_M : Motor inertia ($\text{kg}\cdot\text{m}^2$)

J_L : Load inertia (Motor shaft conversion) ($\text{kg}\cdot\text{m}^2$)

N : Number of motor rotations (min^{-1}) in feed rate V

I : Integrated slow-down rotating angle (rad)

T_L : Load torque ($\text{N}\cdot\text{m}$)



Dynamic brake resistance may fail if the energy ERD consumed by dynamic brake resistance during dynamic brake operation exceeds the energy shown in the following table. Consult with the dealer or sales representative if such a situation is anticipated.

Amplifier Model Name	E_{RD} (J)
RS1□01 □=L/A/N/E	360
RS1□03 □=L/A/N/E	360
RS1□05 □=A/L	1800
RS1□10 □=A/L	2450
RS1□15 □=A/L	2450
RS1A30	9384

■ Allowable frequency of dynamic brake

- The allowable frequency (main circuit power ON/OFF) of the dynamic brake is less than 10 rotations per hour and 50 rotations per day under the conditions of maximum speed. However the load inertia is within the applicable one.



In basic terms, operation of the dynamic brake in six-minute intervals between two operations is permissible at maximum speed, but if the brake is to be operated with greater frequency, the motor speed must be reduced.

Use the following ratio to determine allowable frequency:

$$\frac{6}{(\text{Number of rated rotations/ maximum number of rotations for usage})^2}$$

Materials: Selection details

[Dynamic brake]

Dynamic brake constant table

Amplifier capacity	Motor model number	α	β	J_M (kg·m ²)
RS1A01 RS1L01	Q1AA04003D	204	92.0×10^{-7}	0.01×10^{-4}
	Q1AA04005D	130	34.3×10^{-7}	0.0134×10^{-4}
	Q1AA04010D	53	35.0×10^{-7}	0.0233×10^{-4}
	Q1AA06020D	13	32×10^{-7}	0.141×10^{-4}
	Q2AA04006D	87.8	25.6×10^{-7}	0.057×10^{-4}
	Q2AA04010D	55.2	8.4×10^{-7}	0.086×10^{-4}
	Q2AA05005D	132	10.7×10^{-7}	0.067×10^{-4}
	Q2AA05010D	45.2	7.93×10^{-7}	0.13×10^{-4}
	Q2AA05020D	19.0	46.9×10^{-7}	0.25×10^{-4}
	Q2AA07020D	25.9	11.7×10^{-7}	0.38×10^{-4}
	Q2AA07030D	11.0	13.9×10^{-7}	0.45×10^{-4}
	R2AA04003F	227	4.29×10^{-6}	0.0247×10^{-4}
	R2AA04005F	119	2.96×10^{-6}	0.0376×10^{-4}
	R2AA04010F	41.2	1.56×10^{-6}	0.0627×10^{-4}
	R2AA06010F	32.6	5.04×10^{-6}	0.117×10^{-4}
	R2AA06020F	14.5	2.46×10^{-6}	0.219×10^{-4}
	R2AA08020F	11.3	1.13×10^{-6}	0.52×10^{-4}
	RS1A03 RA1L03	Q1AA06040D	9.13	13.1×10^{-7}
Q1AA07050D		5.24	7.75×10^{-7}	0.636×10^{-4}
Q2AA07040D		10.2	7.08×10^{-7}	0.75×10^{-4}
Q2AA07050D		10.6	3.84×10^{-7}	0.85×10^{-4}
Q2AA08050D		7.71	4.51×10^{-7}	1.30×10^{-4}
Q2AA13050H		5.34	6.99×10^{-7}	2.80×10^{-4}
R2AA06040F		8.82	1.00×10^{-6}	0.412×10^{-4}
R2AA08040F		6.91	4.25×10^{-6}	1.04×10^{-4}
R2AA08075F		5.84	9.10×10^{-6}	1.82×10^{-4}
R2AAB8100H		3.09	3.83×10^{-7}	2.38×10^{-4}
R2AA13050H		4.37	3.55×10^{-6}	3.1×10^{-4}
R2AA13050D		6.46	2.14×10^{-6}	3.1×10^{-4}
R2AA13120B		1.68	1.56×10^{-6}	6×10^{-4}
Q1AA10100D		6.50	6.89×10^{-7}	1.29×10^{-4}
Q1AA10150D		3.95	3.60×10^{-7}	1.61×10^{-4}
Q2AA08075D		9.23	1.71×10^{-7}	2.07×10^{-4}
Q2AA08100D		5.30	1.62×10^{-7}	2.7×10^{-4}
RS1A05 RS1L05		Q2AA10100H	2.78	1.50×10^{-7}
	Q2AA10150H	2.03	0.92×10^{-7}	8.0×10^{-4}
	Q2AA13100H	2.81	3.35×10^{-7}	5.40×10^{-4}
	Q2AA13150H	1.79	2.33×10^{-7}	7.94×10^{-4}
	R2AAB8075F	6.55	4.16×10^{-7}	1.64×10^{-4}
	R2AAB8100F	5.46	2.08×10^{-7}	2.38×10^{-4}
	R2AA10100F	5.35	4.86×10^{-7}	3.5×10^{-4}
	R2AA13120D	4.06	6.45×10^{-7}	6.0×10^{-4}
	R2AA13120L	2.99	1.21×10^{-6}	6×10^{-4}
	R2AA13200L	1.83	3.1×10^{-7}	12.2×10^{-4}
	Q1AA10200D	4.19	0.47×10^{-7}	2.15×10^{-4}
	Q1AA10250D	2.70	0.46×10^{-7}	2.65×10^{-4}
	Q1AA12200D	2.85	0.33×10^{-7}	4.37×10^{-4}
	Q1AA12300D	1.53	0.27×10^{-7}	6.40×10^{-4}
	Q1AA13300D	1.78	0.53×10^{-7}	4.92×10^{-4}
	Q2AA13200H	1.23	0.48×10^{-7}	12×10^{-4}
	Q2AA18200H	1.49	0.36×10^{-7}	20×10^{-4}
	R2AA13200D	1.69	0.91×10^{-7}	12.2×10^{-4}
RS1A15 RS1L15	Q1AA13400D	2.13	0.25×10^{-7}	6.43×10^{-4}
	Q1AA13500D	1.52	0.20×10^{-7}	8.47×10^{-4}
	Q1AA18450M	0.43	0.35×10^{-7}	27.5×10^{-4}
	Q2AA18350H	1.14	0.09×10^{-7}	38×10^{-4}
	Q2AA18450H	0.74	0.09×10^{-7}	55×10^{-4}
	Q2AA18550R	0.52	0.05×10^{-7}	72.65×10^{-4}
	Q2AA22550B	0.46	0.11×10^{-7}	95×10^{-4}
	Q2AA22700S	0.18	0.10×10^{-7}	185×10^{-4}
	R2AA22500L	0.8	0.41×10^{-7}	55×10^{-4}
	Q1AA18750H	0.96	4.77×10^{-8}	52×10^{-4}
	Q2AA18550H	1.15	2.29×10^{-8}	73×10^{-4}
	Q2AA18750L	0.725	2.30×10^{-8}	95×10^{-4}
RS1A30	Q2AA2211KV	0.475	2.47×10^{-8}	186×10^{-4}
	Q2AA2215KV	0.335	1.96×10^{-8}	255×10^{-4}

Amplifier capacity	Motor model number	α	β	J_M (kg·m ²)
RS1E01 RS1N01	Q1EA04003D	276	68.1×10^{-7}	0.01×10^{-4}
	Q1EA04005D	205	39.7×10^{-7}	0.0134×10^{-4}
	Q1EA04010D	82.3	26.1×10^{-7}	0.0233×10^{-4}
	Q2EA04006D	129	7.40×10^{-7}	0.057×10^{-4}
	Q2EA04010D	72.5	4.91×10^{-7}	0.086×10^{-4}
	Q2EA05005D	212	3.48×10^{-7}	0.067×10^{-4}
	Q2EA05010D	71.6	2.55×10^{-7}	0.13×10^{-4}
	R2EA04003F	305	3.19×10^{-6}	0.0247×10^{-4}
	R2EA04005F	171	2.06×10^{-6}	0.0376×10^{-4}
	R2EA04008F	69.7	1.06×10^{-6}	0.0627×10^{-4}
	R2EA06010F	59.1	2.84×10^{-6}	0.117×10^{-4}
	RS1E03 RS1N03	Q1EA06020D	56.3	9.57×10^{-7}
Q2EA05020D		46.4	0.99×10^{-7}	0.25×10^{-4}
Q2EA07020D		57.0	5.22×10^{-7}	0.38×10^{-4}
R2EA06020F		38.8	9.10×10^{-7}	0.219×10^{-4}

The values for α and β are based on an assumed resistance value of the power line of 0 Ω .
If the combination with an amplifier is different than those shown above, consult your dealer or sales office.

■ Regeneration Process

- The regeneration capacity of the servo amplifier depends on the allowable power of the regenerative resistor. When using the servo amplifier with built-in regeneration resistor, be sure to calculate regeneration resistance PM and confirm that $PM < PRI$ (the allowable power for the built-in regeneration resistor) is fulfilled.

When regeneration power PM exceeds the permitted power (PRI) of the built-in regeneration resistor, you can operate by conducting regeneration resistance (PM) calculation, confirming that $PM < PRO$ (the maximum allowable power of the exterior regeneration resistor) is fulfilled, and connecting the optional external regeneration resistor

	Built-in regeneration resistor is available[PRI]	Regeneration resistor connecting number	External regeneration resistor is available[PRO]	Regeneration resistor connecting number	Contact us in case below
RS1□01	PM= 2W and below	I	PM=220Wand below	Refer to "Materials" page 11	PM=220W and up
RS1□03	PM= 5W and below	I	PM=220Wand below		PM=220W and up
RS1□05	PM= 20W and below	I	PM=500Wand below		PM=500Wand up
RS1□10	PM= 90W and below	II	PM=500Wand below		PM=500Wand up
RS1□15	PM=120W and below	II	PM=500Wand below		PM=500Wand up
RS1□30	---	---	PM=500Wand below		PM=500Wand up

- ✎ If using the built-in regeneration resistor, please specify the model number of the servo amplifier with built-in regenerative resistor in reference to "Section 1: Prior to Use – Servo Amplifier Model Number"
- ✎ If using the exterior regeneration resistor, please specify the model number of the servo amplifier without built-in regenerative resistor.

- ✎ When regeneration power PM exceeds the maximum permitted power (PRO) of the external regeneration resistor, reconsider the acceleration constant, load inertia, etc.

- Resistance value of servo amplifier built-in regenerative resistor

Model Number of Servo Amplifier with Built-in Regeneration Resistor	Resistance Value of Built-in Regeneration Resistor
RS1□01 □=L/M/N/P	100Ω
RS1□03 □=L/M/N/P	50Ω
RS1□05 □=A/B	17Ω
RS1A10 □=A/B	10Ω
RS1A15 □=A/B	6Ω

Materials: Selection details

[Calculation method of regeneration power by operations along horizontal axis]

■ Regeneration Power (PM) by Operations along Horizontal Axis

- Regenerative energy is calculated.

$$EM = E_{Hb} = \frac{1}{2} \times N \times 3 \cdot KE \phi \times \frac{T_b}{KT} \times t_b - \left(\frac{T_b}{KT} \right)^2 \times 3 \cdot R \phi \times t_b$$

EM	: Regeneration energy during operations along horizontal axis[J]
EHB	: Regeneration energy during deceleration[J]
KEΦ	: Induced voltage constant[Vrms/min ⁻¹] (Motor constant)
KT	: Torque constant[N·m/Arms] (Motor constant)
N	: Motor rotation speed[min ⁻¹]
RΦ	: Armature resistance[Ω] (Motor constant)
Tb	: Deceleration time[s]
Tb	: Torque during deceleration[N·m] (Tb= Tc - TF)
Tc	: Adjustable speed torque[N·m]
TF	: Friction torque[N·m]

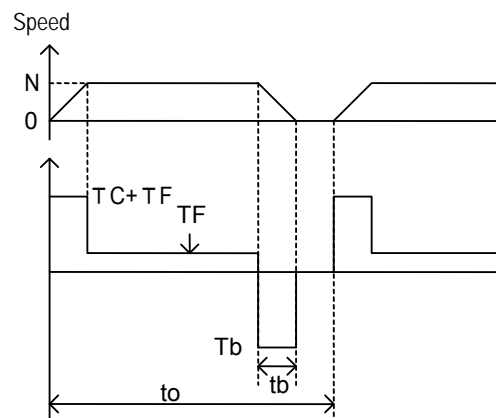

- Effective regeneration power is calculated.

$$PM = \frac{EM}{t_o}$$

PM	: Effective regeneration power [W]
EM	: Regeneration energy during deceleration [J]
To	: Cycle time [s]

Materials: Selection details

[Calculation method of regeneration power by operations along vertical axis]

- Regeneration Power (PM) by Operations along Vertical Axis (With a Gravitational Load)
 - Regenerative energy is calculated.

$$EM = EVUb + EVD + EVDb$$

$$= \frac{1}{2} N \times 3 \cdot K E \phi \times \frac{TUb}{KT} \times tUb - \left(\frac{TUb}{KT} \right)^2 \times 3 \cdot R \phi \times tUb$$

$$+ N \times 3 \cdot K E \phi \times \frac{TD}{KT} \times tD - \left(\frac{TD}{KT} \right)^2 \times 3 \cdot R \phi \times tD$$

$$+ \frac{1}{2} N \times 3 \cdot K E \phi \times \frac{TDb}{KT} \times tDb - \left(\frac{TDb}{KT} \right)^2 \times 3 \cdot R \phi \times tDb$$

EM	:	Regeneration energy during operations along vertical axis[J]
EVUb	:	Regeneration energy during increased deceleration[J]
EVD	:	Regeneration energy during descending run[J]
EVDb	:	Regeneration energy during decreased deceleration[J]
TUb	:	Torque during increased deceleration[N·m]
tUb	:	Increased deceleration time[s]
TD	:	Torque during descending run[N·m] (TD=TM – TF)
tD	:	Descending run time[s]
TDb	:	Torque during decreased deceleration[N·m] (TDb=TC – TF+TM)
tDb	:	Decreased deceleration time[s]
TM	:	Gravitational load torque[N·m]

 When the calculation result of either of EVUb, EVD, or EVDb is negative, calculate EM by considering the value of those variables as 0.

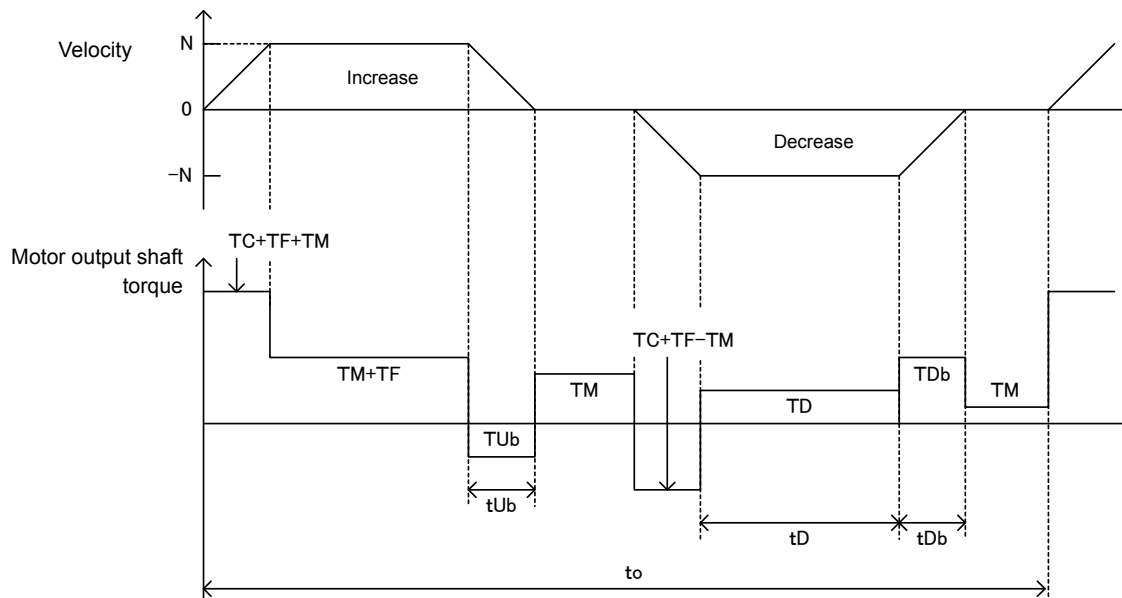

- Effective regeneration power is calculated.

$$PM = \frac{EM}{t_o}$$

PM : Effective regeneration power [W]
 EM : Regeneration energy during increased deceleration/ descending/ decreased deceleration [J]
 t_o : Cycle time [s]

Materials: Selection details

Confirmation method of regeneration power

Confirmation method of regeneration power PM in actual operation

- Regeneration power PM can be easily confirmed in the digital operator or by Q-SETUP setup software.

Digital operator	Monitor mode	Page 12	Regenerative Resistor Operation Percentage
Setup software	Monitor display	Page 12	RegP · Regenerative Resistor Operation Percentage

 The monitor value of the Regenerative Resistor Operation Percentage shows the operating rate of regeneration circuit. The display range is 0.01% to 99.99%.

- The actual regeneration power PM can be calculated from this monitor value by following equation.

Input Supply Voltage : In case of AC200V specification

$$\text{Regeneration power PM (W)} = \frac{400(\text{V}) \times 400(\text{V})}{\text{Regenerative resistance } (\Omega)} \times \frac{\text{Regenerative Resistor Operation Percentage } (\%)}{100(\%)}$$

Input Supply Voltage: In case of AC100V specification

$$\text{Regeneration power PM (W)} = \frac{200(\text{V}) \times 200(\text{V})}{\text{Regenerative resistance } (\Omega)} \times \frac{\text{Regenerative Resistor Operation Percentage } (\%)}{100(\%)}$$

- Calculation example

Servo Amplifier Model Number:

RS1L01AA*

[With built-in regeneration resistance/Input Supply Voltage: AC200V Specification]

Regeneration resistance value:

100Ω

[Built-in Regeneration Resistance]

Monitor Value:

0.12%

[Reg P]

$$\text{Regeneration power PM (W)} = \frac{400(\text{V}) \times 400(\text{V})}{100(\Omega)} \times \frac{0.12 (\%)}{100 (\%)} = \boxed{1.92(\text{W})}$$

 The regeneration power calculated from this monitor value continues to be the target until the end of operations. Regeneration power varies with the voltage fluctuation of the input power supply and changes across the ages of the servo amplifier and the loading device.

 Select regeneration resistance by calculating regeneration power PM from the operation pattern, as per the calculation method of regeneration power PM.

 Install the external regeneration resistor on equipment, and measure the temperature of the external regeneration resistor by the operating condition that the regeneration electric power PM becomes the maximum. Then do sufficient mounting check of alarm not being generated. In addition, it takes 1 to 2 hours until the temperature of the external regeneration resistor is saturated.

Materials: Selection details

[External regenerative resistor]

- Selection of Optional External Regenerative Resistor
 - You can select the combination of external regenerative resistors based on effective regenerative power [PM] sought by the regeneration calculation.





Amplifier Model Number	[PM]	Up to 10W	Up to 30W	Up to 55W	Up to 60W	Up to 110W	Below 220W	220W and over
RS1□01	Resistor Sign	A×1	C×1	E×1	D×2	F×2	E×4	Contact
	Connection Number	III	III	III	IV	IV	VI	
RS1□03	Resistor Sign	B×1	D×1	F×1	C×2	E×2	F×4	Contact
	Connection Number	III	III	III	V	V	VI	

Amplifier Model Number	[PM]	Up to 55W	Up to 125W	Up to 250W	Below 500W	500W and over
RS1□05	Resistor Sign	G×1	H×1	I ×2	H×4	Contact
	Connection Number	III	III	IV	VI	

Amplifier Model Number	[PM]	Up to 125W	Up to 250W	Below 500W	500W and over
RS1□10	Resistor Sign	I×1	H×2	I ×4	Contact
	Connection Number	III	V	VI	

Amplifier Model Number	[PM]	Up to 125W	Up to 250W	Below 500W	500W and over
RS1□15	Resistor Sign	J×1	K×2	J×4	Contact
	Connection Number	III	V	VI	

Amplifier Model Number	[PM]	Up to 125W	Up to 250W	Below 500W	500W and over
RS1□30	Resistor Sign	J×1	L×1	L×2	Contact
	Connection Number	III	III	V	

-  The above resistor sign of a combination of an external regenerative resistor correspond to the following table.
Please select a resistor model name corresponding to a resistor sign.
-  The above connection number of a combination of an external regenerative resistor is on the next page.
Please connect based on the connection number.
-  The permissible effective power of external regenerative resistor is maximum 25% of the rated power under natural air cooling.
-  A regeneration resistance usage rate can be raised about a maximum of 50% by carrying out an air cooling with blower using a cooling fan.

Resistor Sign	Resistor Model Number	Resistance Value	Thermostat Detection temperature (Contact specification)	Permissible Effective Power [PM]	Outline Drawing
A	REGIST-080W100B	100Ω	135°C±7°C (Normally closed contact)	10W	Refer to 'Materials 15'
B	REGIST-080W50B	50Ω		10W	
C	REGIST-120W100B	100Ω		30W	
D	REGIST-120W50B	50Ω		30W	
E	REGIST-220W100B	100Ω		55W	
F	REGIST-220W50B	50Ω		55W	
G	REGIST-220W20B	20Ω		55W	
H	REGIST-500CW20B	20Ω	100°C±5°C (Normally closed contact)	125W	Refer to 'Materials16'
I	REGIST-500CW10B	10Ω		125W	
J	REGIST-500CW7B	7Ω		125W	
K	REGIST-500CW14B	14Ω		125W	
L	REGIST-1000W6R7B	6.7Ω	140°C±5°C (Normally closed contact)	250W	Refer to 'Materials17'

Connection of regenerative resistance

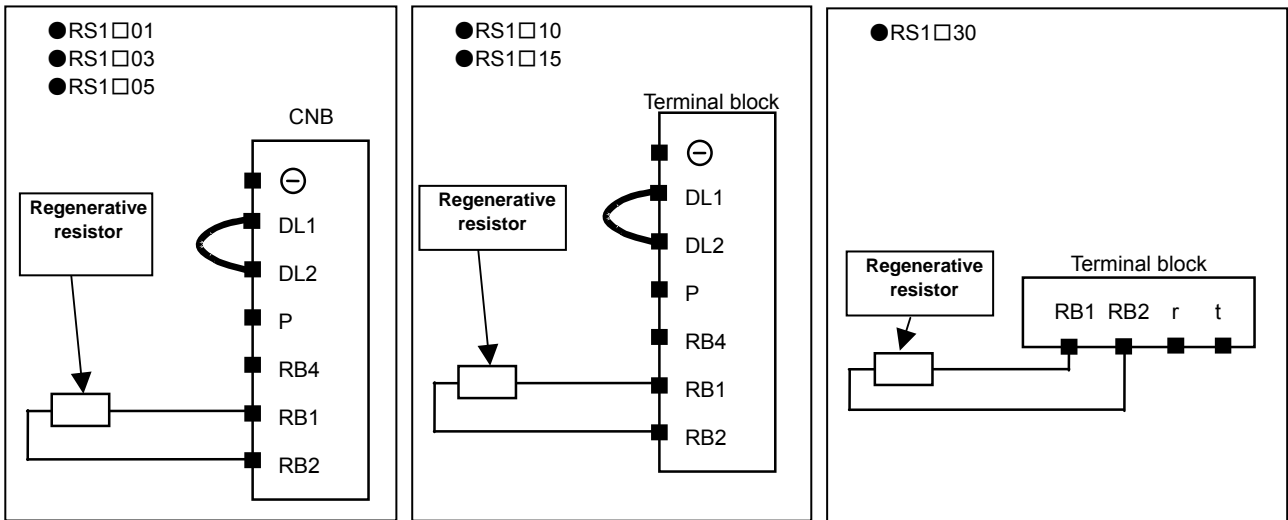

- ✎ Please make sure to install the external regenerative resistor with twisted wires and use as a short wire which is up to 5 meters long as possible.
- ✎ Use nonflammable electric wire or perform non-combustible processing (silicon tube, etc.) for connecting cable and wired, and install wiring so as to not come in contact with the built-in unit.
- ✎ Please make sure to change the set-up of “System Parameter” and “Regenerative Resistance Selection” in line with the kind of regenerative resistor you connect.

Connection of the Thermostat of a Regenerative Resistor

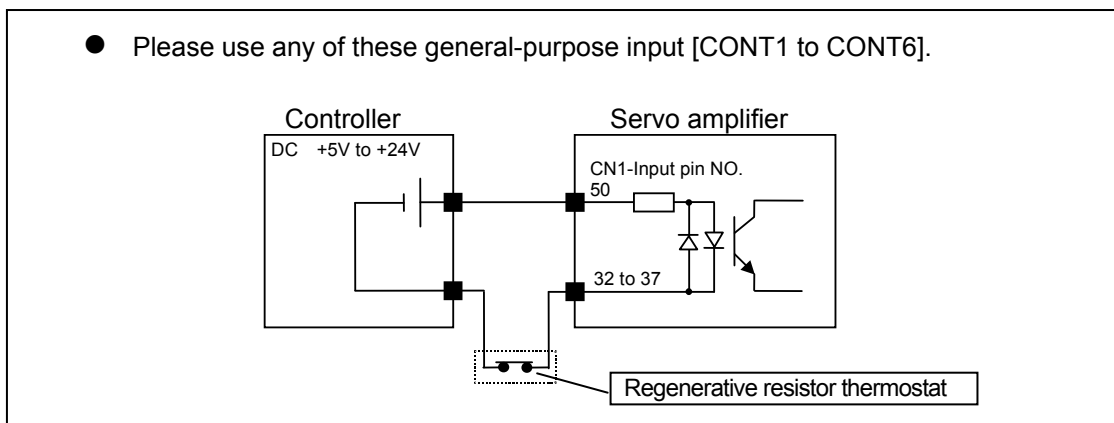

- ✎ Please allocate the connected general-purpose input (any of [CONT1 to CONT6]) to [Group9 40 External Trip Input Function of General Parameter].

Parameter Set-up Example: When connecting the thermostat to CONT6

The external trip function will be valid when [0DH:CONT6_OFF] CONT6 is turned on in [Grop6 40 External Trip Input Function]

Alarm (ALM-55) will be output from the servo amplifier when the thermostat of a generative resistor trips (the contact point comes off) because of heating.

Materials: Selection details

[External regenerative resistor]

■ Connection Number of External Regenerative Resistor combination

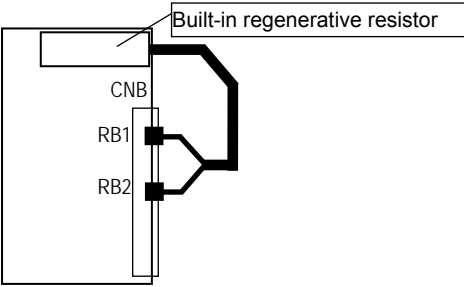
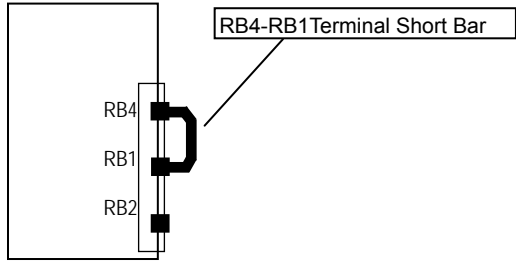
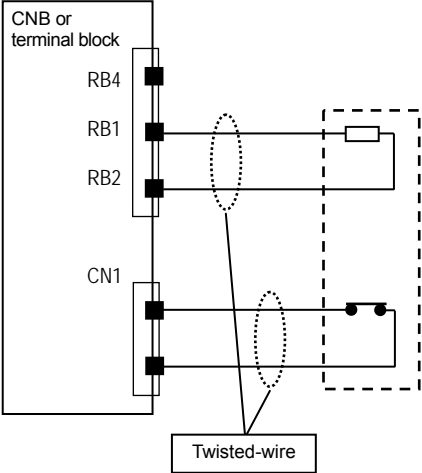
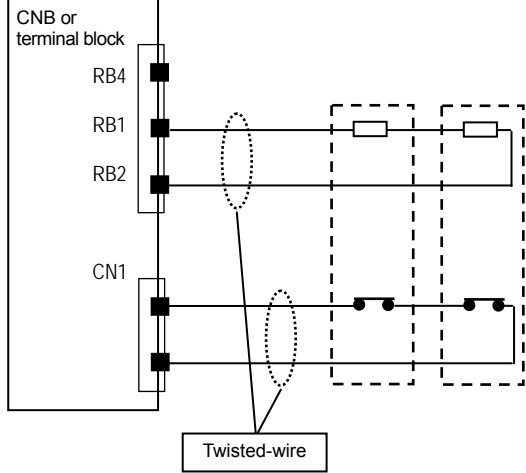
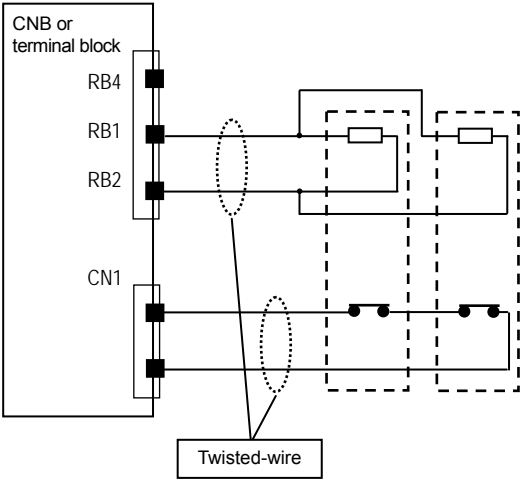
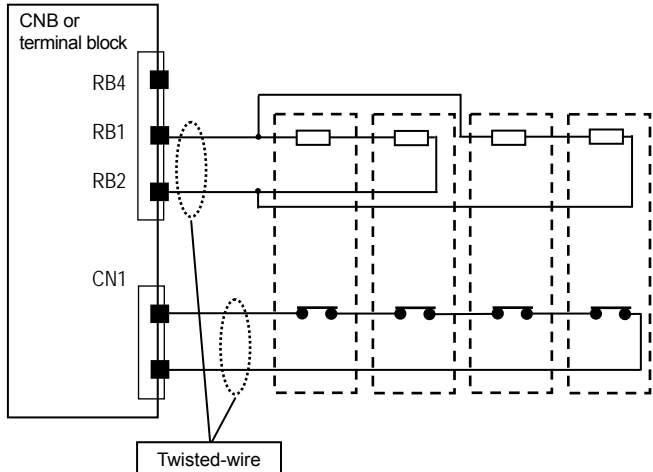
<p>Connection I</p>  <p>Built-in regenerative resistor</p> <p>CNB</p> <p>RB1</p> <p>RB2</p>	<p>Connection II</p>  <p>RB4-RB1 Terminal Short Bar</p> <p>RB4</p> <p>RB1</p> <p>RB2</p>
<p>Connection III</p>  <p>CNB or terminal block</p> <p>RB4</p> <p>RB1</p> <p>RB2</p> <p>CN1</p> <p>Twisted-wire</p>	<p>Connection IV [×2] Series Connection</p>  <p>CNB or terminal block</p> <p>RB4</p> <p>RB1</p> <p>RB2</p> <p>CN1</p> <p>Twisted-wire</p>
<p>Connection V [×2] Parallel Connection</p>  <p>CNB or terminal block</p> <p>RB4</p> <p>RB1</p> <p>RB2</p> <p>CN1</p> <p>Twisted-wire</p>	<p>Connection VI [×4] Series/Parallel Connection</p>  <p>CNB or terminal block</p> <p>RB4</p> <p>RB1</p> <p>RB2</p> <p>CN1</p> <p>Twisted-wire</p>

■ Protection function of regenerative resistance

With the R series servo amplifier, the regenerative resistance protection function is specified by parameter selections. Appropriate protection for regenerative resistance is applied by setting parameters according to the type of regenerative resistance to be connected. Set the appropriate parameters by following the instructions given below.

● The protection functions are divided into three main types:



- (1) Protection for a short-time, high load factor (using built-in or external regenerative resistance): An error is detected when the power absorption of regenerative resistance is extremely high over a short time period (100msec to 10 seconds). A 'Regenerative Error' alarm ("ALM_43") is issued when this error is detected.
- (2) Protection when allowable power absorption is exceeded for long time (using built-in regenerative resistance): An error is detected when the power absorption of the built-in regenerative resistance exceeds the allowable power absorption over a long time period (from a few seconds to a few minutes). An 'Internal Overheat' alarm ("ALM_54") is issued when this error is detected.
- (3) Protection during thermostat operation of the external regenerative resistor: An error is detected when the external trip function is started. An 'External error / external trip' alarm ("ALM_55") is issued when this error is detected.



● Two parameters requiring settings are given below.

(1)	Regenerative resistance selection	Regenerative resistance built-in type	[0B]
(2)	External trip input function	General parameter	[Group9 40]



● Relationship between parameter settings and protection functions



Regenerative resistance in use		Parameter setting		Protection function operation		
Resistor	Thermostat	Regenerative resistance selection	External trip input function	Regenerative error [ALM_43]	Internal overheat [ALM_54]	External Alarm External Trip [ALM_55]
Not Connecting	---	00:_Not_Connect	---	Invalid	Invalid	---
Built-in Regenerative Resistance	---	01:_Built-in_R	---	Valid	Valid	---
External Regenerative Resistance	---	02:_External_R	---	Valid	Invalid	---
External Regenerative Resistance	Connect to servo amplifier	02:_External_R	Setting	Valid	Invalid	Valid



  Make appropriate settings to regenerative resistance [System parameter/Page0B] when using built-in regenerative resistance. If these parameter settings are incorrect, normally detected errors related to built-in regenerative resistance may not be detected, possibly causing the burning/fuming of regenerative resistance.

  The built-in/ external regenerative resistance may generate heat even if the overheat alarm etc. has not been generated. Do not touch the servo amplifier for 30 minutes after power is disconnected in the case of a power failure, as there is a risk of burn.

■ Attention at installation of the regenerative resistor

  Incorrect parameter settings may cause irregular operation of the protection functions. Upon an alarm, confirm its cause and adjust the settings appropriately.

  The place where corrosive gas has occurred, and when there is much dust, insulated degradation, corrosion, etc. may arise. Therefore be careful of an attachment place.

  Arrangement of the external regeneration resistor should open an interval so that it is not influenced by generation of heat from other parts.

Materials: Selection details

[External regenerative resistor dimension]

Unit:mm

External Dimension of Regenerative Resistor

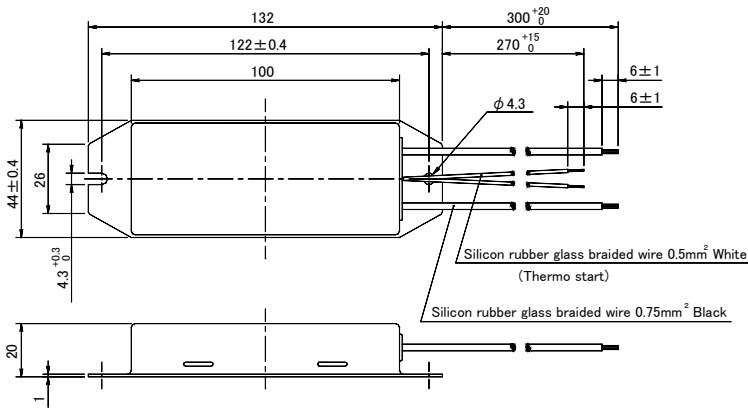

	Model number	Thermostat Detection temperature (Contact specification)
1	REGIST-080W100B	135°C±7°C (Normal close contact)
2	REGIST-080W50B	135°C±7°C (Normal close contact)

Mass: 0.19kg

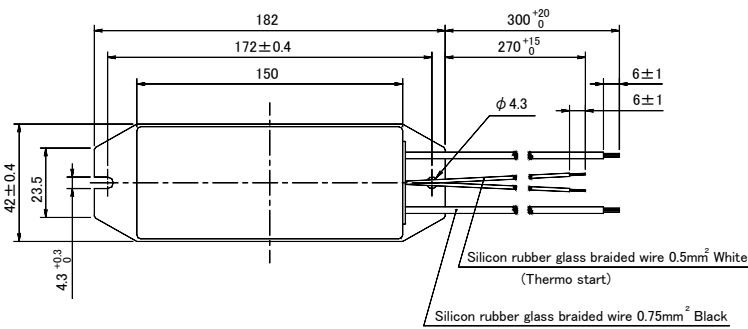

	Model number	Thermostat Detection temperature (Contact specification)
1	REGIST-120W100B	135°C±7°C (Normal close contact)
2	REGIST-120W50B	135°C±7°C (Normal close contact)

Mass: 0.24kg

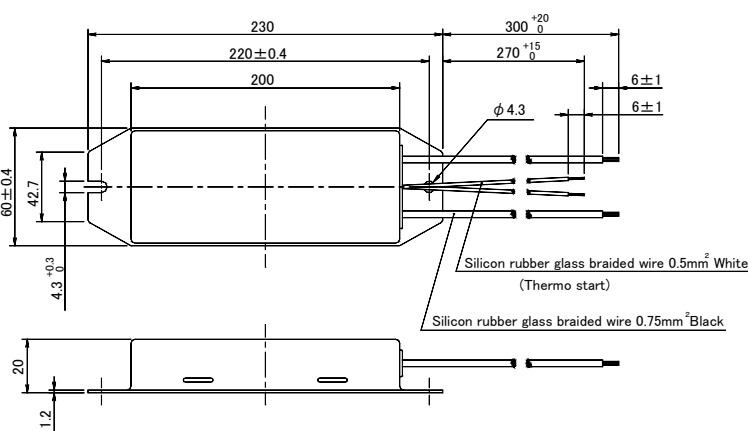
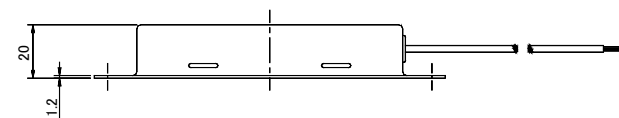

	Model number	Thermostat Detection temperature (Contact specification)
1	REGIST-220W50B	135°C±7°C (Normal close contact)
2	REGIST-220W20B	135°C±7°C (Normal close contact)
3	REGIST-220W100B	135°C±7°C (Normal close contact)

Mass: 0.44kg

Materials: Selection details

[External regenerative resistor dimension]

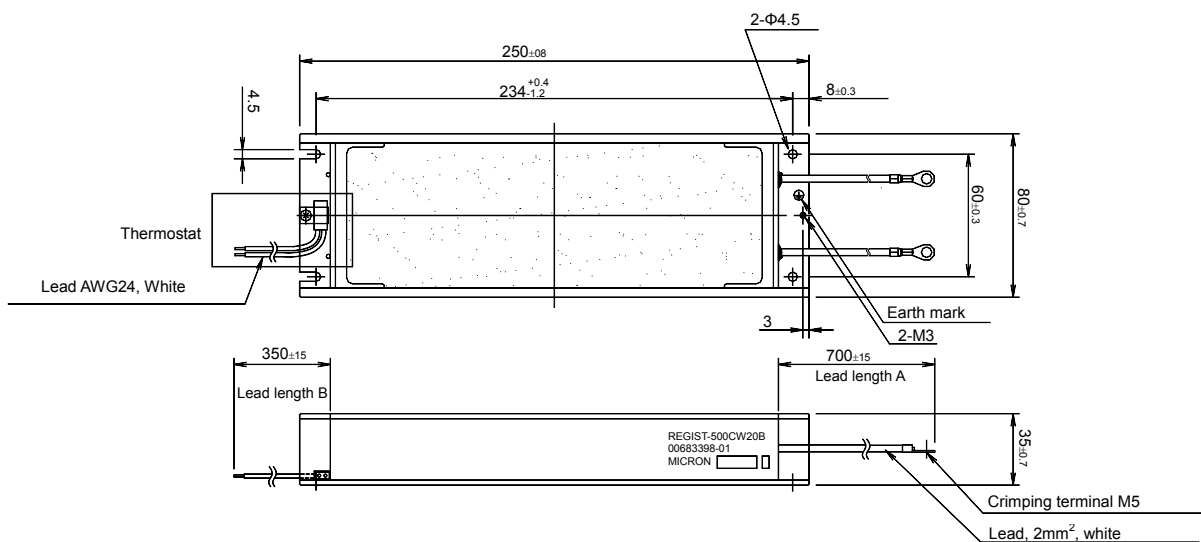

	Model number	Thermostat Detection temperature (Contact specification)
1	REGIST-500CW20B	$100^\circ\text{C} \pm 5^\circ\text{C}$ (Normal close contact)
2	REGIST-500CW20	None
3	REGIST-500CW10B	$100^\circ\text{C} \pm 5^\circ\text{C}$ (Normal close contact)
4	REGIST-500CW10	None
5	REGIST-500CW7B	$100^\circ\text{C} \pm 5^\circ\text{C}$ (Normal close contact)
6	REGIST-500CW7	None
7	REGIST-500CW14B	$100^\circ\text{C} \pm 5^\circ\text{C}$ (Normal close contact)
8	REGIST-500CW14	None

Mass: 1.4kg

Materials: Selection details

[External regenerative resistor dimension]

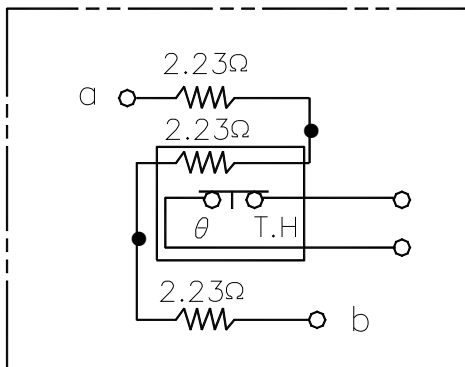
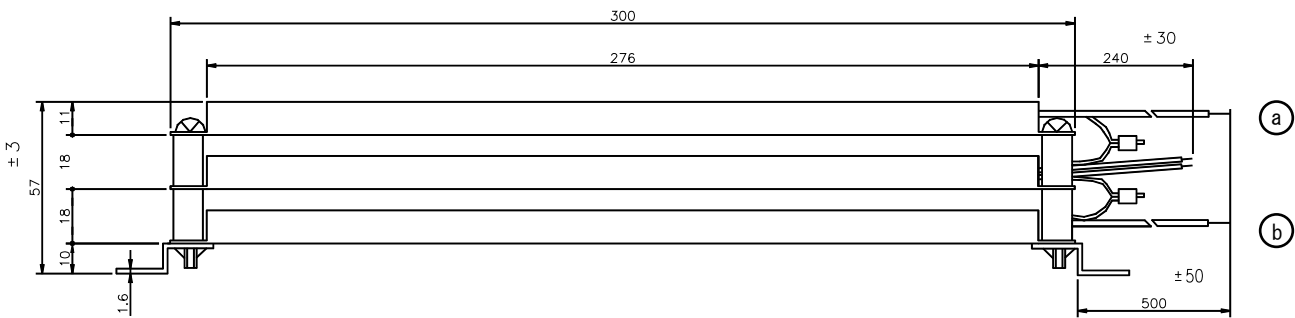
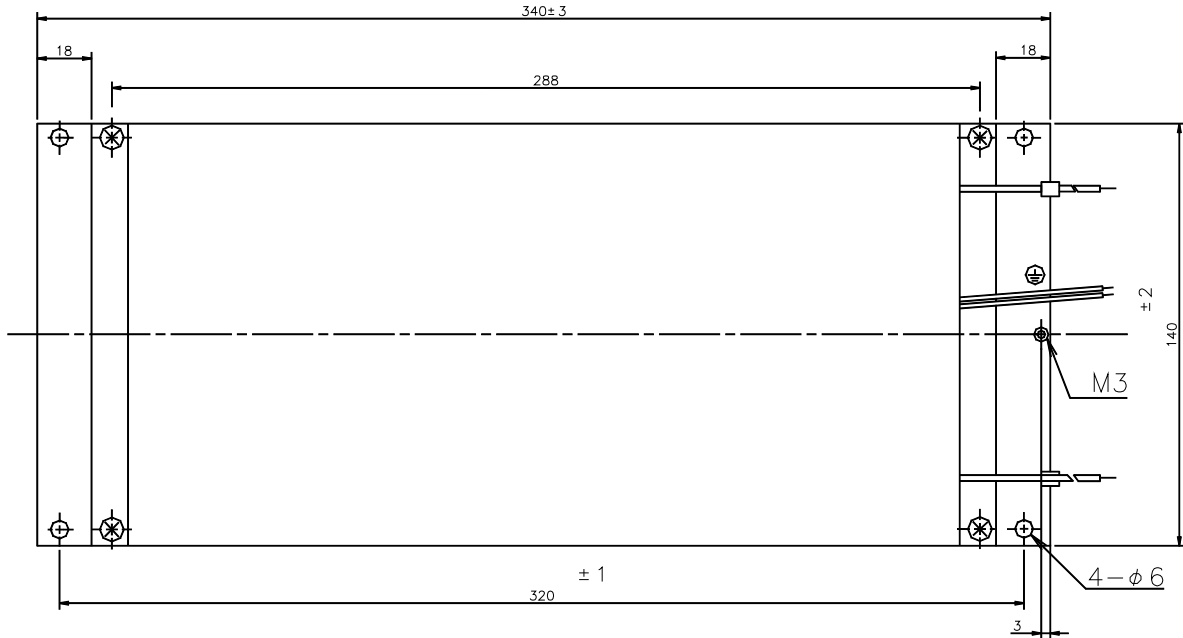

Connection diagram



	Model number	Thermostat Detection temperature (Contact specification)
1	REGIST-1000W6R7B	140°C±5°C (Normal close contact)

Mass: 3.0kg



Materials: International standards



International standards conformity

- Outline of International Standards Conformity
 - RS1servo amplifier conforms to the international standards below.

Mark	International standards	Standard number	Certification Organization
	UL standard	UL508C (File No.E179775)	UL (Underwriters Laboratories inc.)
	CSA standard		
	EN standard	EN50178 EN61000-6-2 EN61800-3	TÜV (TÜV Product Service Japan, Ltd.)
	KC standard: (Korea Certification)	KN22 (EMI) KN24 (EMS)	National Radio Research Agency Korea Communications Commission Republic of Korea

- Q and R servomotor conforms to the international standards below.

Display	International standards	Standard number	Certification Organization
	UL standard	UL1004 UL1446 (File No.E179832)	UL (Underwriters Laboratories inc.)
	EN standards	IEC-34-1 IEC34-5	TÜV (TÜV Product Service Japan, Ltd.)
	KC standard: (Korea Certification)	KN22 (EMI) KN24 (EMS)	National Radio Research Agency Korea Communications Commission Republic of Korea

-  For products conforming to international standards, some specifications may differ from the standard product due to prerequisites necessary for obtaining approval. Contact the manufacturer for more details.
-  The file number of UL is available at the UL homepage: <http://www.ul.com/database/>.
-  Please contact your dealer or sales representative if you need the above certification.

Materials: International standards

International standards conformity

● Precautions for conformity standards

- (1) Make sure to use servo amplifier and servo motor in a proper combination. Check "Section 1 : Prior to use --- Servo amplifier type number.
- (2) Make sure to install the servo amplifier in your control panel in an environment where the pollution level specified in EN50178 and IEC664 is no less than 2 (pollution level 1, 2). The control panel installation configuration (under IP54) must exclude exposure to water, oil, carbon, dust, etc.
- (3) The servo amplifiers must be used under the conditions specified in overvoltage category III, EN50178. For the interface, use a DC power supply with reinforced and insulated input and outputs.
- (4) Always ground the protective earth terminals of the servo amplifier to the power supply earth. (⚡)
- (5) When connecting grounding wire to the protective earth terminal, always connect one wire in one terminal; never connect jointly with multiple wires or terminals.
- (6) When connecting the leakage stopper, make sure to connect the protective earth terminal to the power supply earth. (⚡)
- (7) Connect earthing wire by using a crimping terminal with insulated tube, so that the connected wire will not touch the neighboring terminals.

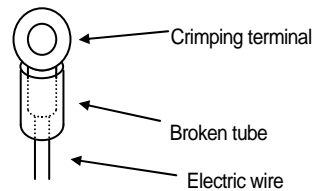

- (8) For wire relays, use a fixed terminal block to connect wires; never connect wires directly.

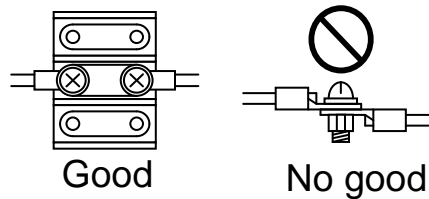

- (9) Connect an EMC filter to the input power supply of the unit.
- (10) Use an EN/ IEC-standard compatible no-fuse circuit breaker and electromagnetic contactor.

Materials: International standards [Compliance with EC Directives]

■ Compliance with EC Directives

Our company has performed the requisite low voltage and EMC testing in accordance with EC Directives related to CE marking through a separate, third-party certifying authority.

Directive classification	Classification	Test	Test standard
Low voltage Directive (Servo amplifier)	---	---	EN50178: 1997
EMC Directive (Servo amplifier / servo motor)	Emission	Conducted emission	EN55011: A1/1999
		Radiated emission	EN55011: A1/1999
	Immunity test	Electrostatic discharge immunity	EN61000-4-2: A2/2001
		Radiated electromagnetic field immunity	EN61000-4-3: A2/2001
		Electrical first transient/ burst immunity	EN61000-4-4: A2/2001
		Conducted disturbance immunity	EN61000-4-6: A1/2001
		Surge immunity	EN61000-4-5: A1/2001
		Voltage Dips & Interruptions immunity	EN61000-4-11: A1/2001
		Adjustable speed electrical power drive system	EN61800-3/1996 :A11/2000
Low voltage Directive (Servo motor)	---	Rotating electrical machines- Part1: Rating and performance	IEC-34-1
		Rotating electrical machines-Part5:Classification of degrees of protection provided by enclosures of rotating electrical machines(IP code)	IEC34-5
		Rotating electrical machines-Part9: Noise limits	IEC34-9

 For the EMC Directives, tests are performed by general installation and countermeasure methods, in our company as machines and configurations differ depending on customers' needs.

 This servo amplifier has been authorized to display CE marking based on the recognition certificate issued by a separate, third-party certifying authority. Accordingly, customers are instructed to perform the final conformity tests for all instruments and devices in use.

Materials: International standards [Compliance with EC Directives]

- Precautions for EMC Directives

Use the following guidelines below for the RS1 servo system in order to conform the customer's equipment and devices to the EMC Directives.

- (1) A metallic material must be used for the door and main body of control panel.
- (2) The joints of the top and side panels must be masked and welded.
- (3) Parts joined with screws must be welded to prevent noise from leaking out from joints.
- (4) When joining parts with screws or spot welding, the welding space must be within 10cm.
- (5) Use an EMI gasket so that there is zero clearance between the door and control panel.
- (6) Install EMI gasket uniformly to the contact points between door and main body of control panel.
- (7) Perform conductivity processing on the EMI gasket, door and main body of control panel to confirm their conductivity.
- (8) Ground the noise filter frame to the control panel.
- (9) Ground the servo amplifier chassis provided by the customer.
- (10) Use shield cables for the motor power line and encoder cable.
- (11) Ground the shield of motor power wire and encoder cable to the control panel with the clamp.
- (12) Ground and clamp the shield of motor power line and encoder cable to the frame of the servo amplifier.
- (13) Use a conducting metal P clip or U clip to ground and clamp the shield wire, and fix it directly with metal screws. Do not ground by soldering electric wire to the shield wire.

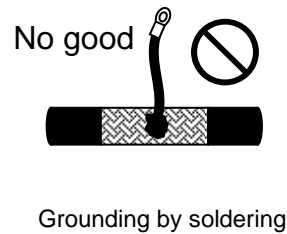
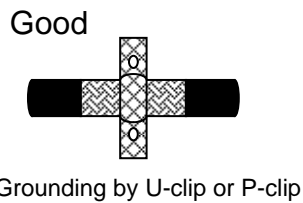

- (14) Wrap the zero-phase reactor four times around the primary side of the noise filter.

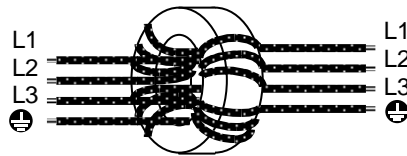

- (15) Wire the servo amplifier at a short distance from the secondary side of noise filter.
- (16) Wire the primary side and secondary side of the noise filter separately.

Materials: International standards [Compliance with EC Directives]



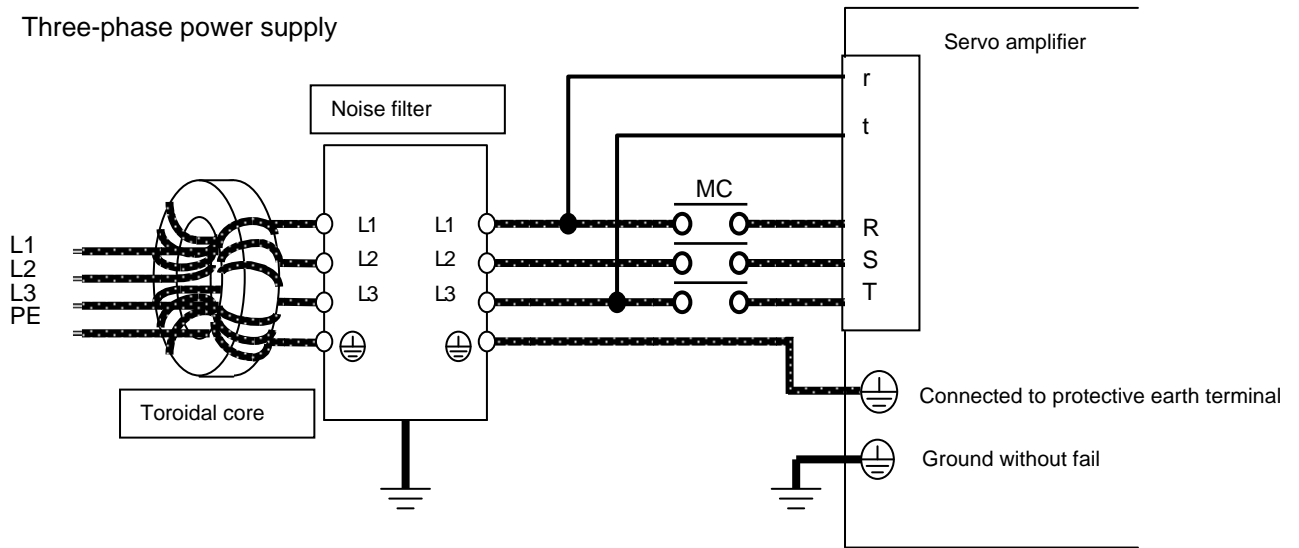

Installation of noise filter and servo amplifier

Three-phase power supply

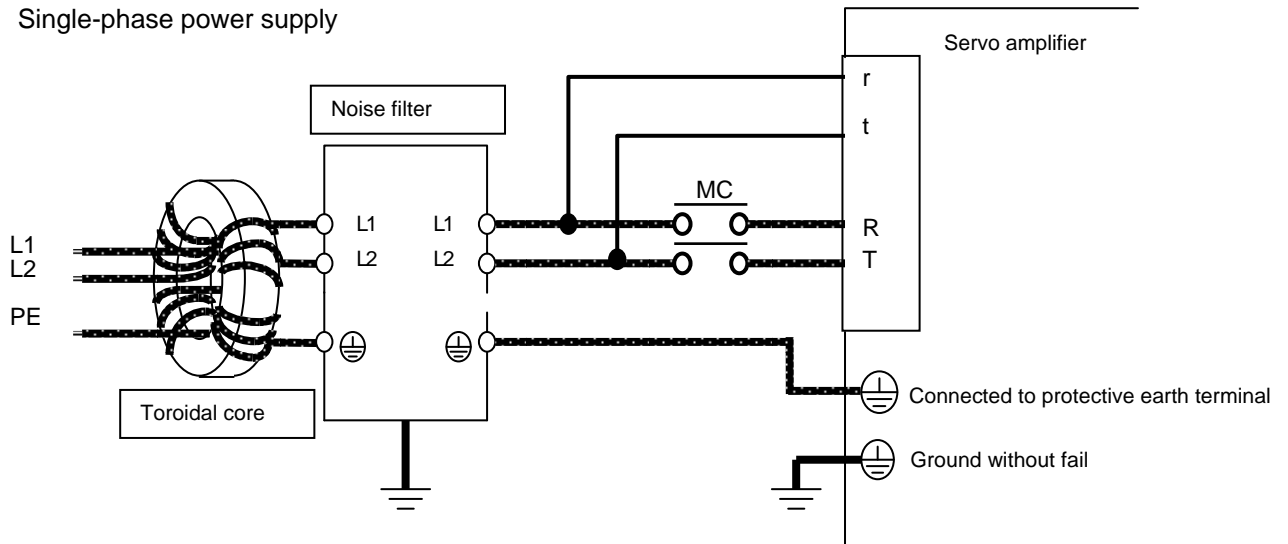

Single-phase power supply



-  Always ground the frame of the noise filter.
-  Install wiring by separating the primary and secondary wiring of the noise filter as much as possible.
-  Keep wiring from the noise filter to servo amplifier as short as possible.
-  Connect the servo amplifier to the secondary side of noise filter.

Materials: International standards [Compliance with EC Directives]

■ Recommended prevention components

● Noise filter

Model Number	Specifications	Manufacturer
3SUP-HK30-ER-6B	Rated voltage:Line-Line 500 V Rated armature current: 30 A, Leakage current: 250mA max	Okaya Electric Industries Co. Ltd.
3SUP-HK50-ER-6B	Rated voltage:Line-Line 500 V Rated armature current: 50 A, Leakage current: 250mA max	Okaya Electric Industries Co. Ltd.
RF3020-DLC	Rated voltage:Line-Line 440 to 550 V Rated armature current: 20 A, Leakage current: 27mA max	RASMI ELECTRONICS LTD.
RF3030-DLC	Rated voltage:Line-Line 440 to 550 V Rated armature current: 30 A, Leakage current: 27mA max	RASMI ELECTRONICS LTD.
RF3070-DLC	Rated voltage:Line-Line 440 to 550 V Rated armature current: 70 A, Leakage current: 27mA max	RASMI ELECTRONICS LTD.
RF1010-DLC	Rated voltage:Line-Neutral 250 V Rated armature current: 10 A, Leakage current: 27mA max	RASMI ELECTRONICS LTD.
FS5559-35/33	Rated voltage:Line-Line 480 V Rated armature current: 35 A, Leakage current: 6.5mA max	SCHAFFNER

● Toroidal core

Model Number	External diameter	Internal diameter	Manufacturer
251-211	65 mm	36 mm	SCHAFFNER
R-63/38/25A_MA070	63 mm	38 mm	JFE FERRITE CORPORATION

Okaya Electric Industries Co. Ltd.: <http://www.okayaelec.co.jp/>

RASMI ELECTRONICS LTD. : <http://www.rasmi.com/>

SCHAFFNER : <http://www.schaffner.com/>

JFE FERRITE CORPORATION : <http://www.jfe-frt.com/>

 Please inquire the order for the RASMI product of our company.

■ Implementation of check test

EMC testing of equipment and devices which the RS1 servo system is built-in should meet the emission and immunity (electromagnetic compatibility) standards for the usage environment / and operating conditions.

It is necessary to follow the instructions mentioned above and conduct a final conformity check test after review.

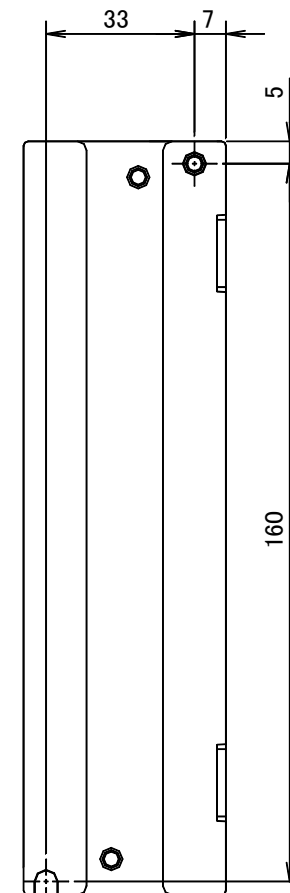
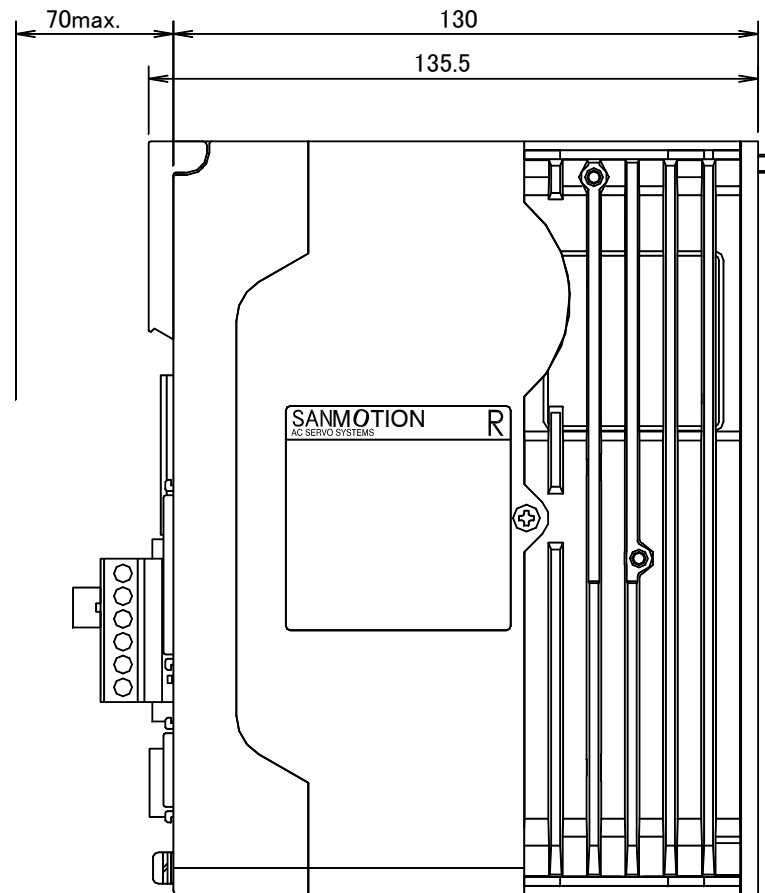
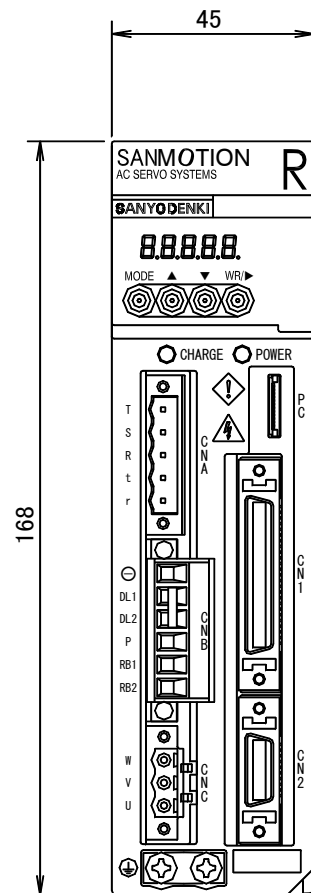
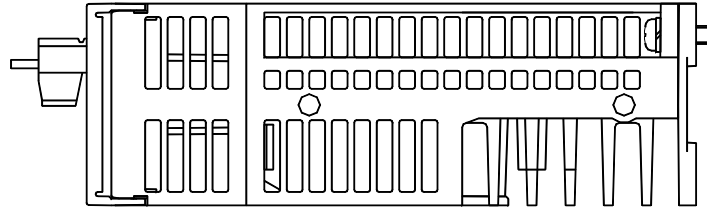

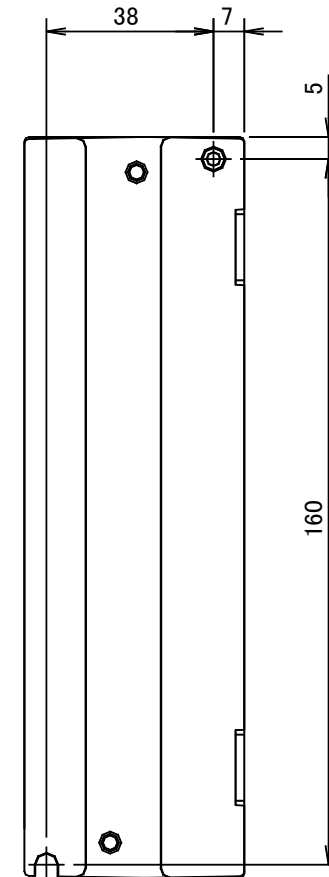
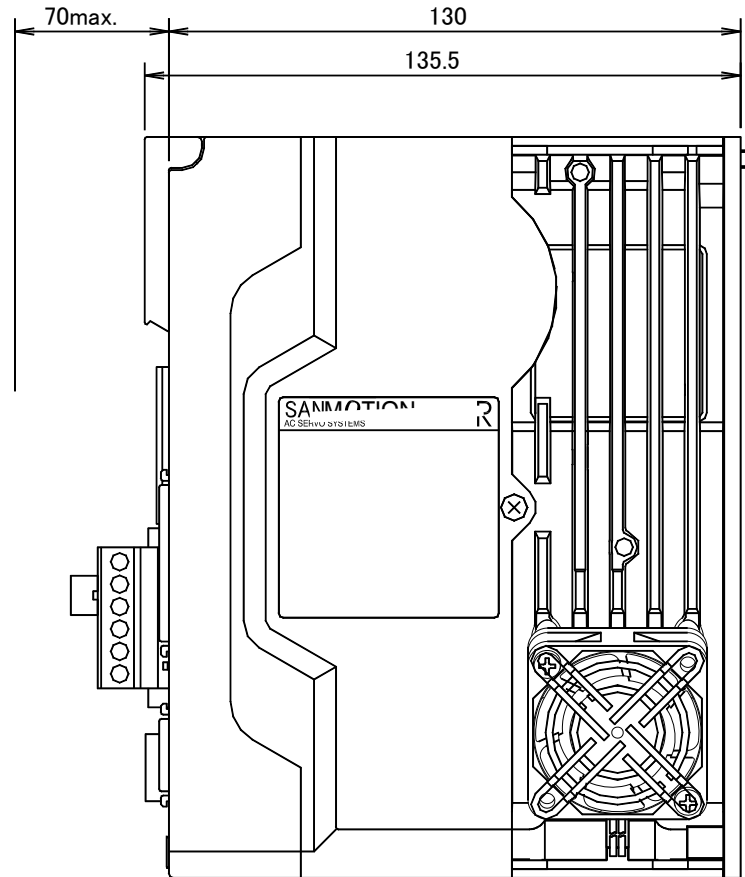
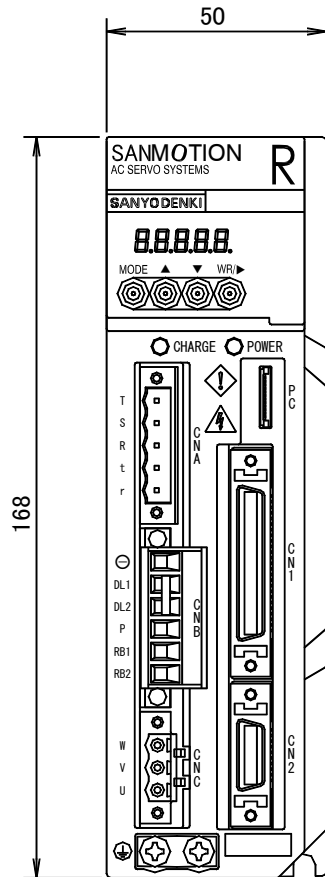
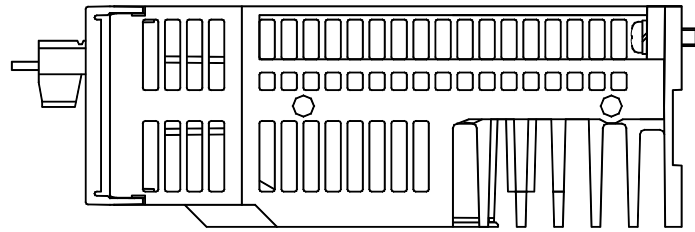

Materials: Dimension

[RS1□05]

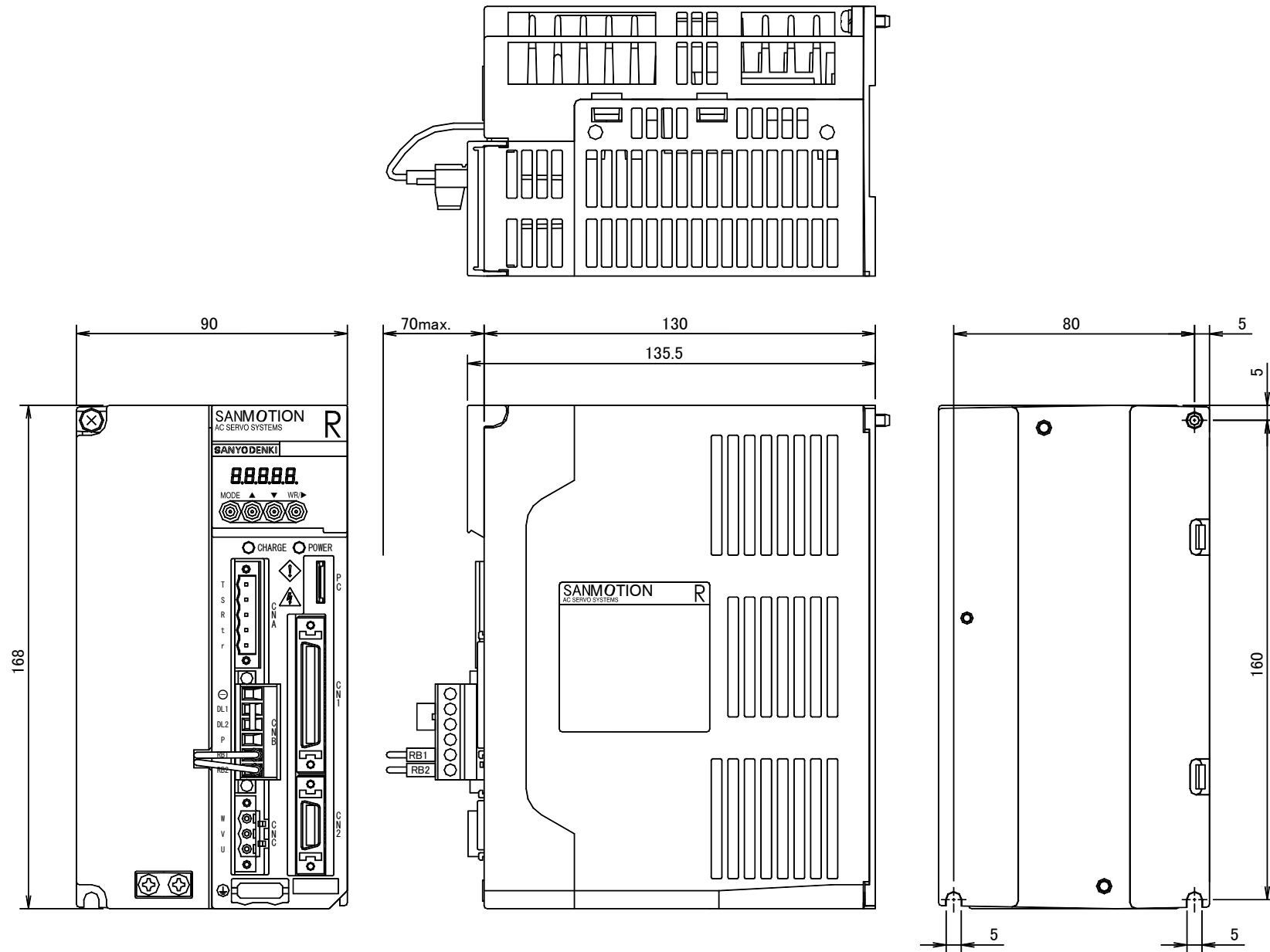

Materials: Dimension

[RS1□10]

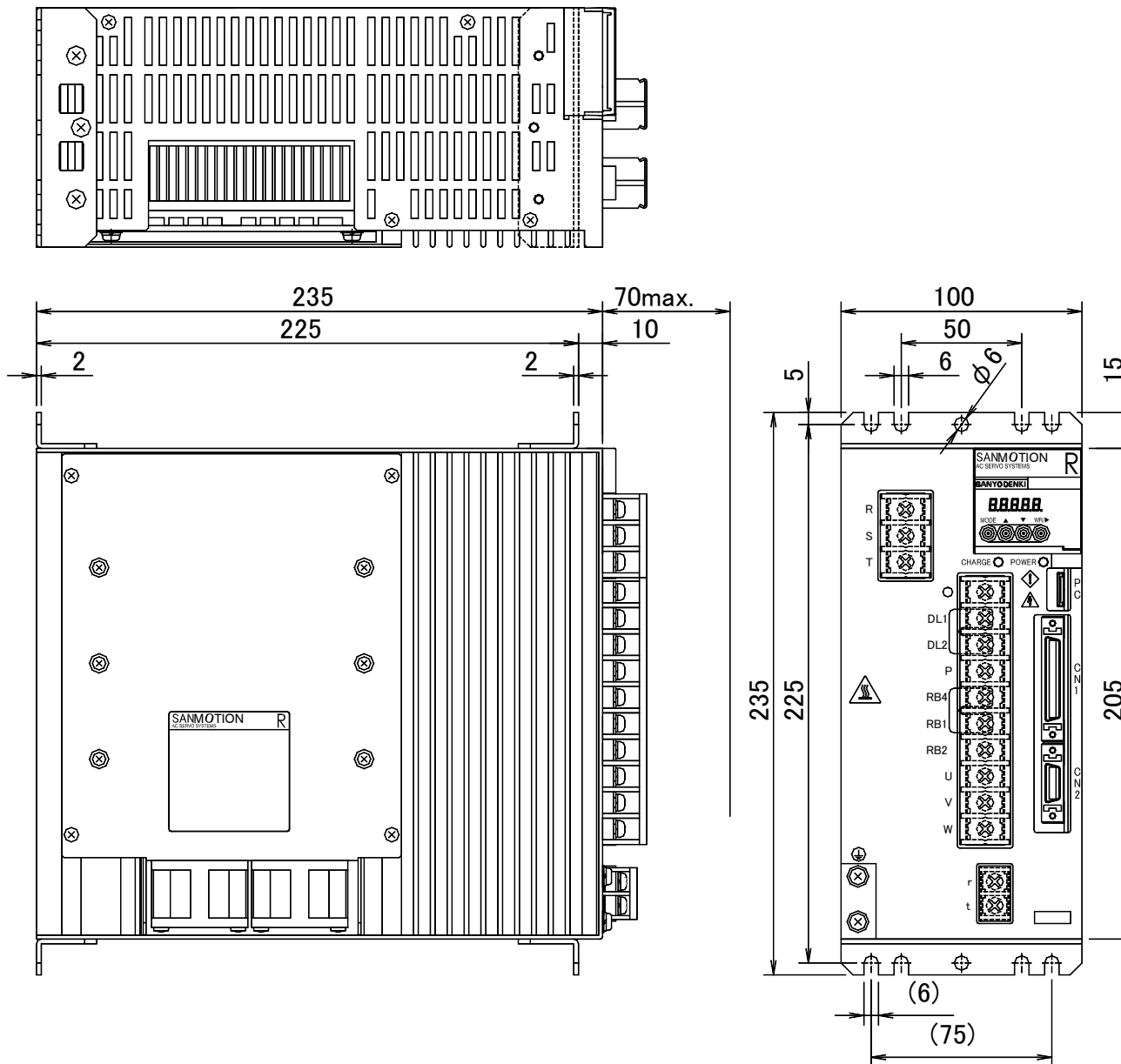

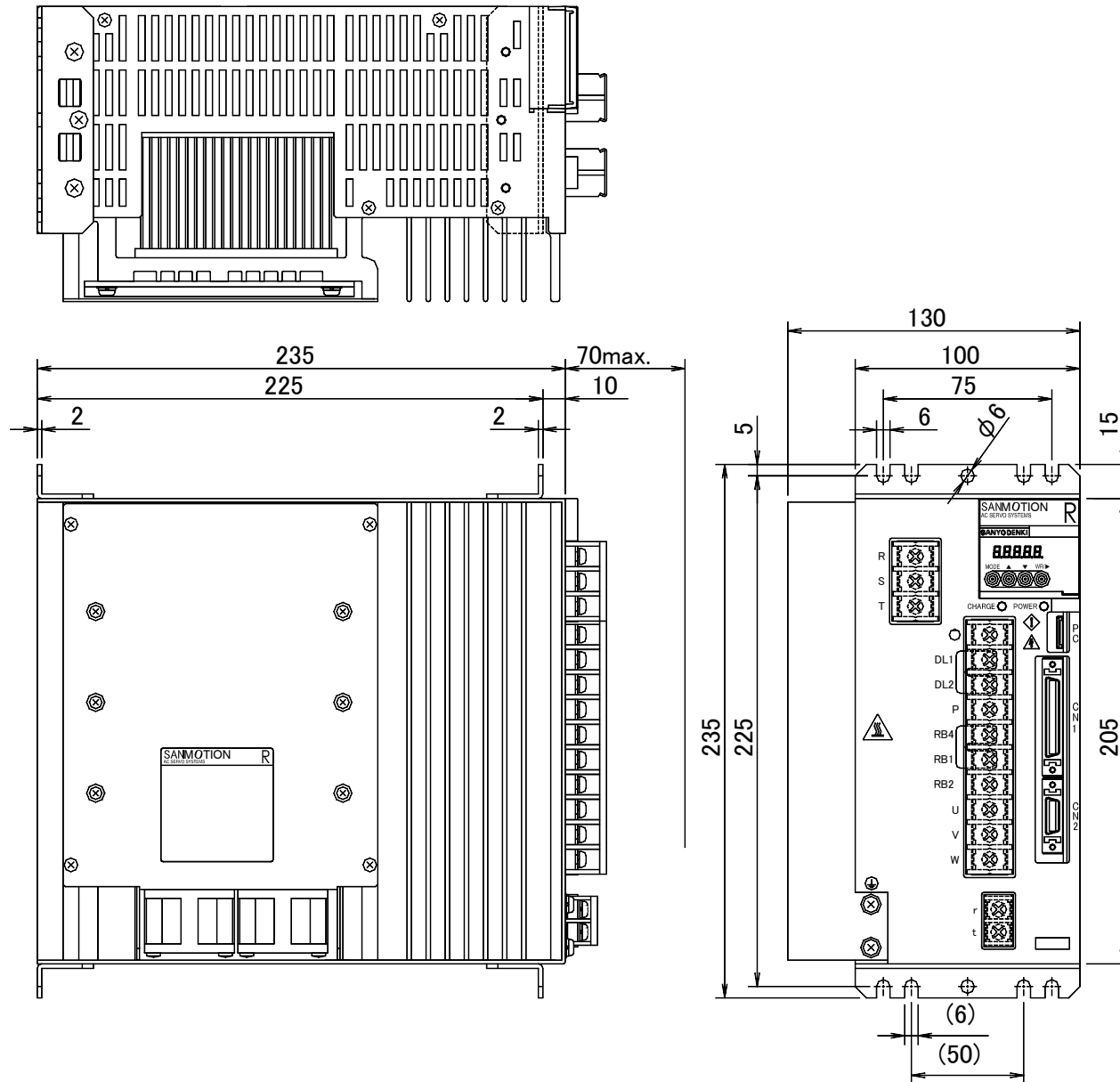

Materials: Dimension

[RS1□30]

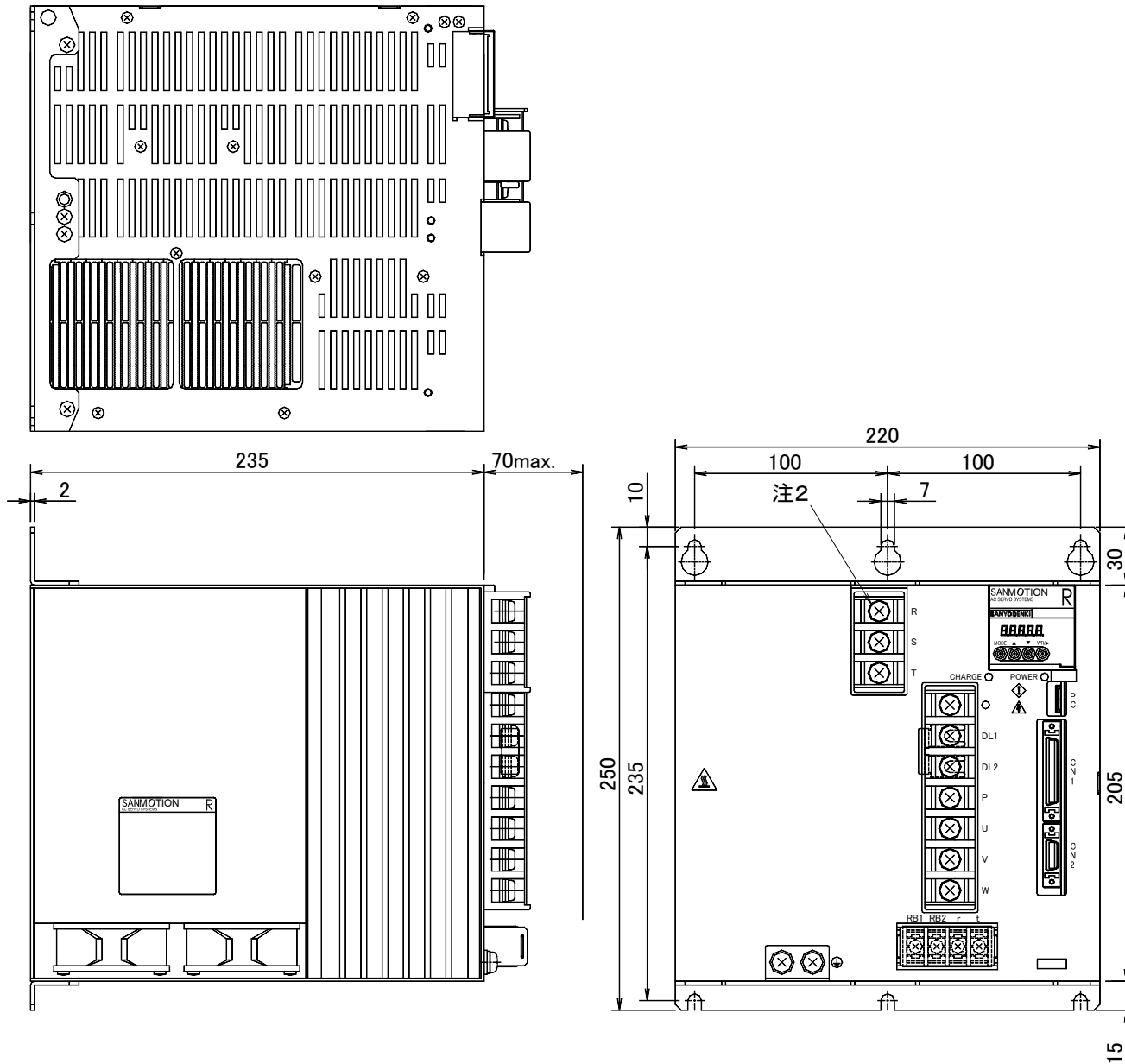

Materials: Dimension

[Q1 □40 to □76]

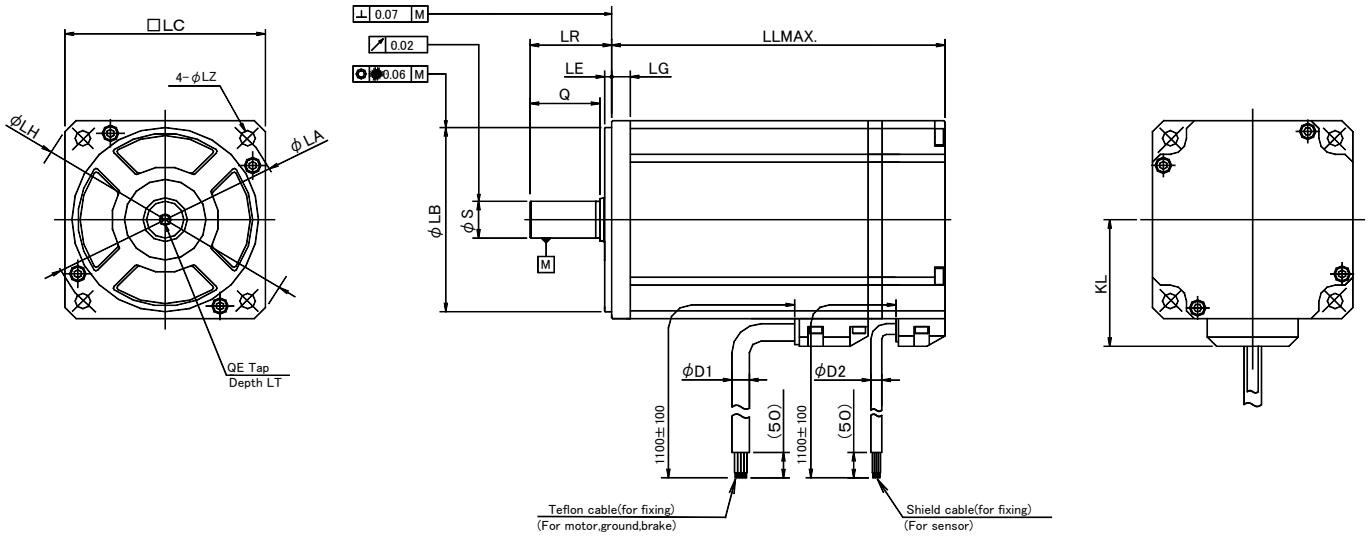

MODEL	Wire-saving incremental encoder [PP031]		Battery backup method absolute encoder [PA035C]		LG	KL	LA	LB	LE	LH	LC	LZ	LR	S	Q	QE	LT	D1	[PP031]	[PA035C]	Oil seal
	Without Brake	With Brake	Without Brake	With Brake															D2	D2	
Q1□A04003△□◇	75±2	121.5±2	80.3±2	125.3±2										0 6-0.008	-	-					
Q1□A04005△□◇	81±2	127.5±2	87.3±2	131.3±2	5	30	46	0 30-0.021	2.5	54	40	4.5	25	0 8-0.009	-	-	-	7			
Q1□A04010△□◇	100±2	146.5±2	106.3±2	150.3±2																	
Q1□A06020△□◇	111±2	140±2	116±2	145±2	6	41	70	0 50-0.025	3	81	60	5.5	30	0 14-0.011	M5	12	7.5		4.7	5	Optional
Q1AA06040△□◇	140±2	169±2	145±2	174±2																	
Q1AA07075△□◇	154±2	177.5±2	163.6±2	187±2	8	50	90	0 70-0.030	3	100	76	5.5	40	0 16-0.011	35	M5	12	7.5			

Materials: Dimension

[Q1 □100 to □180]

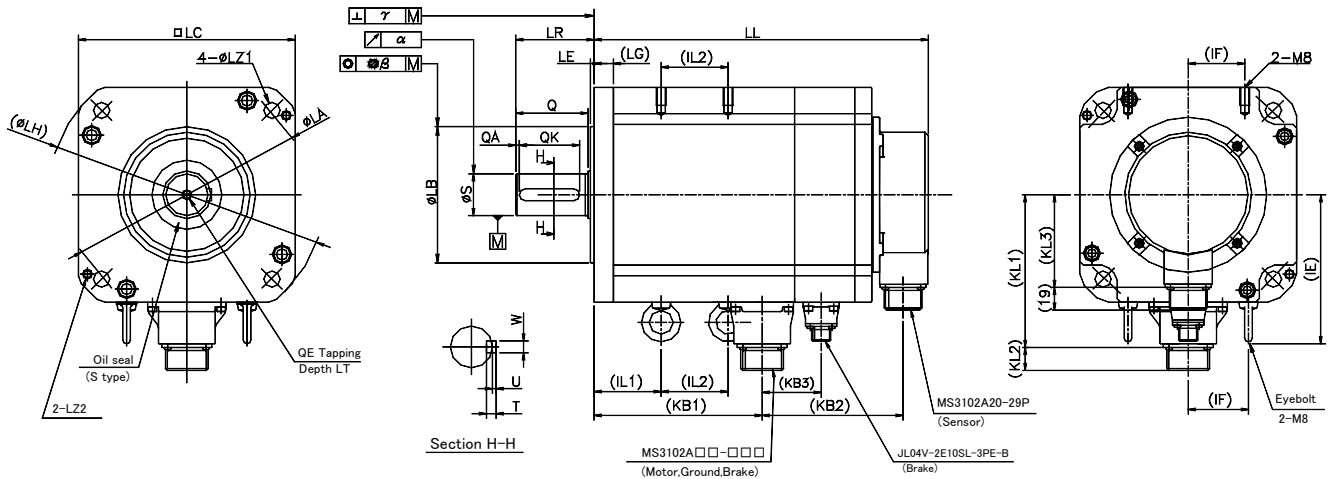

MODEL	Wire-saving incremental encoder [PP031]					Battery backup method absolute encoder [PA035C]					Connector Note 1			[PP031]		[PA035C]				
	Without Brake	Without Brake				Without Brake	Without Brake				Motor, Earth	Brake(only when brake is installed) Note2		LG	KL1	KL2	KL3	KL3	LA	LB
	LL	KB2	LL	KB2	KB3	LL	KB2	LL	KB2	KB3	MS3102A	JL04V-2E								
Q1AA10100△□◇	184		219			193		229												
Q1AA10150△□◇	209	80	244	116	51	218	90	254	125	51	20-15P	10SL-3PEB	10	78	19	63	63	115	0	95-0.035
Q1AA10200△□◇	234		269			243		279												
Q1AA10250△□◇	259		294			268		304												
Q1AA12100△□◇	168		204			183		219												
Q1AA12200△□◇	205	72	241	108	45	220	87	256	123	45	24-11P	10SL-3PE-B	12	93	21	67	63	135/145	0	110-0.035
Q1AA12300△□◇	242		278			257		293												
Q1AA13300△□◇	205		254			220		270												
Q1AA13400△□◇	232	67	281	117	-	247	84	297	134	-	24-11P		12	98	21	80	63	145	0	110-0.035
Q1AA13500△□◇	269		318			284		334												
Q1AA18450△□◇	288	67	338	117	-	304	84	354	134	-	24-11P		16	123	21	80	63	200	0	114.3-0.035
Q1AA18750△□◇	384	72	434	122	54	400	89	450	139	54	32-17P	10SL-3PE-B	19	144	22					

MODEL	LE	LH	LC	LZ1	LZ2	LR	S	Q	QA	QK	W	T	U	KB1	α	β	γ	QE	LT	IE	IF	IL1	IL2	
Q1AA10100△□◇														84										
Q1AA10150△□◇	3	130	100	9	-	45	22-0.013	40	3	32	6-0.030	6	2.5	109	0.02	0.08	0.08	M6	20	-	-	-	-	-
Q1AA10200△□◇														134										
Q1AA10250△□◇														159										
Q1AA12100△□◇														76										
Q1AA12200△□◇	3	162	120	9	-	45	22-0.013	40	3	32	6-0.030	6	2.5	113	0.02	0.08	0.08	M6	20	-	-	-	-	-
Q1AA12300△□◇														150										
Q1AA13300△□◇	4	165	130	9	M6	55	28-0.013	50	3	42	8-0.036	7	3	150	0.02	0.08	0.08	M8	25	-	-	-	-	-
Q1AA13400△□◇														144										
Q1AA13500△□◇														181										
Q1AA18450△□◇	3	230	180	13.5	M8	65	35-0.016	60	3	50	10-0.036	8	3	200	0.02	0.08	0.08	M8	25	124	50	93	50	
Q1AA18750△□◇						79																		
							42-0.016	75	3	67	12-0.043	8	3	291										

Note1) Connector becomes a waterproof specification when intuition is combined, and use the connector of the waterproof specification for the receiving side plug for IP67, please.

Note2) All the brake connectors become JL04V-2E70SL-3PE-B for CE of the A DC24V brake.

Materials: Dimension

[Q2 □42 to □86]

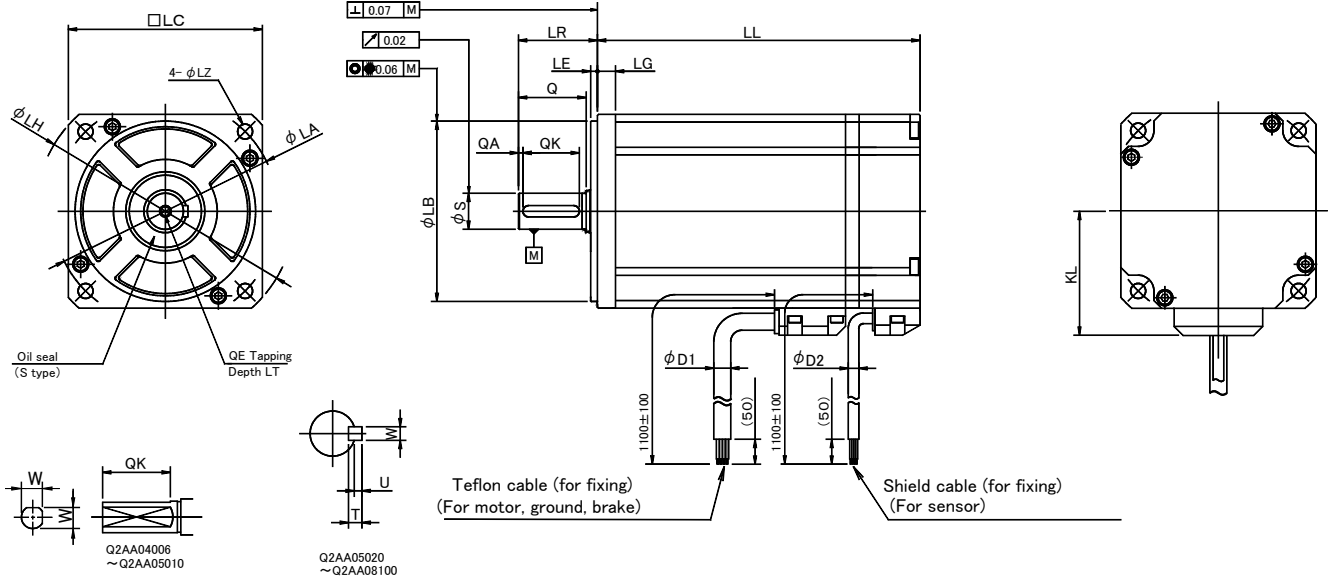

MODEL	Wire-saving incremental encoder [PP031]		Battery backup method absolute encoder [PA035C]		LG	KL	LA	LB	LE	LH	LC	LZ	LR
	Without Brake	With Brake	Without Brake	With Brake									
Q2□A04006△□◇	80±2	112±2	88±2	120±2	5	31	48	0 34-0.025	2	57	42	3.5	24
Q2□A04010△□◇	94±2	126±2	102±2	134±2									
Q2□A05005△□◇	79±2	108±2	88±2	110.5±2	5	38	60	0 50-0.025	2.5	71.5	54	4.5	24
Q2□A05010△□◇	87±2	115±2	96±2	118.5±2									
Q2□A05020△□◇	103±2	131±2	112±2	134.5±2	8	50	90	0 70-0.030	3	100	76	5.5	30
Q2□A07020△□◇	96±2	121±2	105±2	131±2									
Q2AA07030△□◇	103±2	128±2	113±2	138±2	8	55	100	0 80-0.030	3	115	86	6.6	35
Q2AA07040△□◇	110±2	135±2	120±2	145±2									
Q2AA07050△□◇	118±2	143±2	128±2	153±2	8	55	100	0 80-0.030	3	115	86	6.6	35
Q2AA08050△□◇	128±2	164±2	136.5±2	172.5±2									
Q2AA08075△□◇	145±2	181±2	153.5±2	189.5±2	8	55	100	0 80-0.030	3	115	86	6.6	35
Q2AA08100△□◇	164±2	198±2	170.5±2	206.5±2									

MODEL	S	Q	QA	QK	W	T	U	QE	LT	D1	[PP031]	[PA035C]	Oil seal
											Oil seal	D2	Oil seal
Q2AA04006△□◇	0	20	-	15	6.5±0.2	-	-	-	-	7	4.7	5	Without Note 1
Q2AA04010△□◇	7-0.009												
Q2AA05005△□◇	0	20	-	15	7.5±0.2	-	-	M3	8	7.5	4.7	5	With
Q2AA05010△□◇	8-0.009												
Q2AA05020△□◇	0	25	2	20	4	4	1.5	M4	10	7.5	4.7	5	With
Q2AA07020△□◇	11-0.011												
Q2AA07030△□◇	0	25	2	20	5	5	2	M5	12	7.5	4.7	5	With
Q2AA07040△□◇	14-0.011												
Q2AA07050△□◇	0	30	2	25	5	5	2	M5	21	7.5	4.7	5	With
Q2AA08050△□◇	16-0.011												
Q2AA08075△□◇	0	30	2	25	5	5	2	M5	21	7.5	4.7	5	With
Q2AA08100△□◇	16-0.011												

(Unit: mm)

Note1) If oil seal is needed for Q2AA04*, the overall motor length is different.

Materials: Dimension

[Q2 □100 to □220]

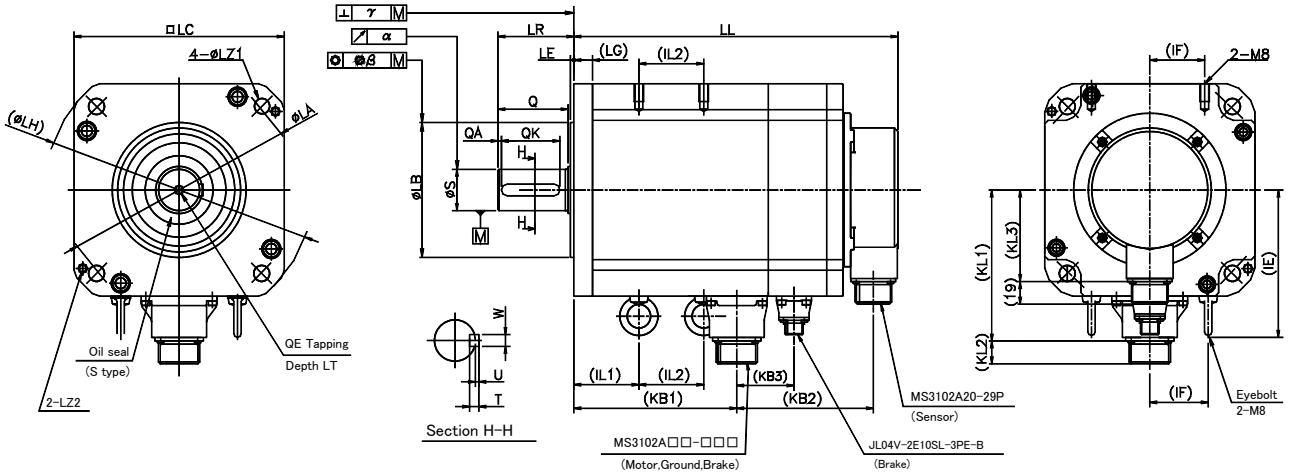

MODEL	Wire-saving incremental encoder [PP031]			Battery backup method absolute encoder [PA035C]			Connector Note 1				[PP031]		[PA035C]							
	Without Brake	With Brake		Without Brake	With Brake		Motor grounding	Brake(only when brake is installed) Note2	LG	KL1	KL2	KL3	KL3	LA	LB					
Q2AA10100△□◇	196	77	231	113	51	207	90	243	125	51	20-15P	10SL-3PE-EB	10	78	19	67	63	115	0 95-0.035	
Q2AA10150△□◇	226		261			237		273												
Q2AA13050△□◇	135	67	171	103	-	150	84	186	120	-	24-11P	10SL-3PE-EB	12	98	21	80	63	145	0 110-0.035	
Q2AA13100△□◇	152		188			203		203												
Q2AA13150△□◇	169		205			220		220												
Q2AA13200△□◇	186		226			241		241												
Q2AA18200△□◇	171	67	221	117	-	186	84	236	134	-	24-11P	10SL-3PE-EB	16	123	21	80	63	200	0 114.3-0.035	
Q2AA18350△□◇	203		253			268		268												
Q2AA18450△□◇	218		268			284		284												
Q2AA18550△□◇	282		332			348		348												
Q2AA18750△□◇	332	72	382	122	54	298	89	348	139	54	32-17P	10SL-3PE-EB	19	144	22	80	63	200	0 114.3-0.035	
Q2AA22550△□◇	252	82	309	140	82	265	97	323	155	82	24-11P	10SL-3PE-EB	19	141	21	80	63	235	0 200-0.046	
Q2AA22700△□◇	310		368			323		381												
Q2AA2211K△□◇	335	73	393	131	61	355	94	406	145	61	32-17P	10SL-3PE-EB	19	162	22	80	63	235	0 200-0.046	
Q2AA2215K△□◇	394		452			414		465												

MODEL	LE	LH	LC	LZ1	LZ2	LR	S	Q	QA	QK	W	T	U	KB1	α	β	γ	QE	LT	IE	IF	IL1	IL2
Q2AA10100△□◇	3	130	100	9	-	45	0	40	3	32	0	6	2.5	98	0.02	0.08	0.08	M6	20	-	-	-	-
Q2AA10150△□◇							22-0.013				6-0.030			128									
Q2AA13050△□◇	4	165	130	9	M6	55	0	50	3	42	0	6	2.5	47	0.02	0.08	0.08	M6	20	-	-	-	-
Q2AA13100△□◇							22-0.013				6-0.030			64									
Q2AA13150△□◇							28-0.013				8-0.036			81									
Q2AA13200△□◇							28-0.013				8-0.036			98									
Q2AA18200△□◇	3	230	180	13.5	M8	65	0	60	3	50	0	8	3	83	0.02	0.08	0.08	M8	25	-	-	-	-
Q2AA18350△□◇							35-0.016				10-0.036			115									
Q2AA18450△□◇							35-0.016				10-0.036			130									
Q2AA18550△□◇	3	230	180	13.5	M8	79	0	75	3	67	0	8	3	189	0.02	0.08	0.08	M10	25	124	50	85	50
Q2AA18750△□◇							42-0.016				12-0.043			239									100
Q2AA22550△□◇	4	270	220	13.5	M10	79	0	75	3	67	0	10	4	149	0.03	0.08	0.10	M10	25	142	60	55	50
Q2AA22700△□◇							55-0.019				16-0.043			207									110
Q2AA2211K△□◇	4	270	220	13.5	M10	79	0	75	3	67	0	10	4	241	0.03	0.08	0.10	M10	25	142	60	69	120
Q2AA2215K△□◇							55-0.019				16-0.043			300									180

Note1) Connector becomes a waterproof specification when intuition is combined, and use the connector of the waterproof specification for the receiving side plug for IP67, please.

Note2) All the brake connectors become JL04V-2E70SL-3PE-B for CE of the A DC24V brake.

Materials: Dimension

[R2 □40 to □86]

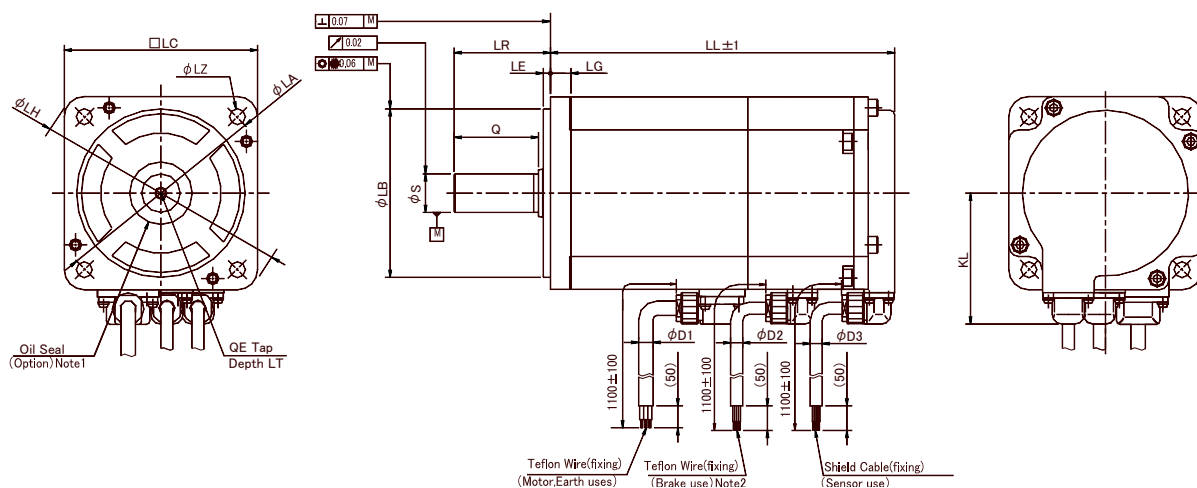

MODEL	Without Oil Seal		Without Oil Seal Note1		LG	KL	LA	LB	LE	LH	LC	LZ	LR
	Battery backup method absolute encoder		Battery backup method absolute encoder										
	Without Brake	With Brake	Without Brake	With Brake									
R2□A04003△□◇	51.5	87.5	56.5	92.5	5	35.4	46	0 30-0.021	2.5	56	40	2-Φ 4.5	25
R2EA04005△□◇	56.5	92.5	61.5	97.5									
R2AA04008△□◇ R2AA04010△□◇	72	108	77	113									
R2□A06010△□◇	58.5	82.5	65.5	89.5	6	44.6	70	0 50-0.025	3	82	60	4-Φ 5.5	25
R2□A06020△□◇	69.5	97.5	76.5	104.5									
R2AA08020△□◇	66.3	102	73.3	109	8	54.4	90	0 70-0.030	3	108	80	4-Φ 6.6	30
R2AA06040△□◇	95.5	123.5	102.5	130.5									
R2AA08040△□◇	78.3	114	85.3	121	8	54.4	90	0 70-0.030	3	108	80	4-Φ 6.6	40
R2AA08075△□◇	107.3	143	114.3	150									
R2AAB8075△□◇	114.3	140.2	114.3	140.2	8	59.4	100	0 80-0.03	3	115.5	86	4-Φ 6.6	35
R2AAB8100△□◇	137	163	137	163									

MODEL	S	Q	QE	LT	D1	D2	Absolute
							D3
R2AA04003△□◇	0 6-0.008	20	-	-	6	5	5
R2AA04005△□◇	0 8-0.009						
R2EA04008△□◇							
R2AA04010△□◇							
R2□A06010△□◇	0 8-0.009	25	M5	12	6	5	5
R2□A06020△□◇	0 14-0.011						
R2AA08020△□◇							
R2AA06040△□◇							
R2AA08075△□◇	0 16-0.011	35	M5	12	6	5	5
R2AAB8075△□◇		30					
R2AAB8100△□◇							

Note1) If an oil seal is needed, the motor whole length differs.

Note2) For the one without brake, there is no brake connector (or cable) attached.

Materials: Dimension

[R2 □130]

R2 motor, flange size 130mm 0.5kW to 1.8kW

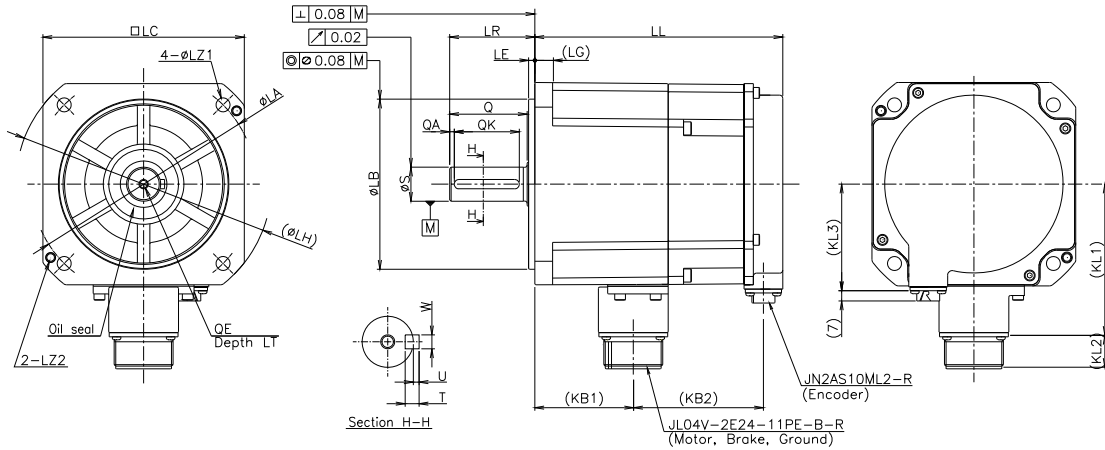

Servo motor model number	Battery backup method absolute encoder Absolute encoder for incremental system						Incremental encoder						LG	KL1	KL2	LA
	Without Brake			With Brake			Without Brake			With Brake						
	LL	KB2	KL3	LL	KB2	KL3	LL	KB2	KL3	LL	KB2	KL3				
R2AA13050△□◇	103	44	69	139.5	81	69	115.5	57	38	153.5	93	38	12	98	21	145
R2AA13120△□◇	120.5			160	84		133			174	96					
R2AA13180△□◇	138			179	86		150.5			192	96					

Servo motor model number	LB	LE	LH	LC	LZ1	LZ2	LR	S	Q	QA	QK	W	T	U	KB1	QE	LT
R2AA13050△□◇	0 110-0.035	4	165	130	9	M6	55	0	50	3	42	0	6	2.5	46	M6	20
R2AA13120△□◇								22-0.013				6-0.030			64		
R2AA13180△□◇															81		

✓ Please contact us for the dimensions for the encoder below. Battery less absolute encoder [RA035C]

R2 motor, flange size 130mm 2kW

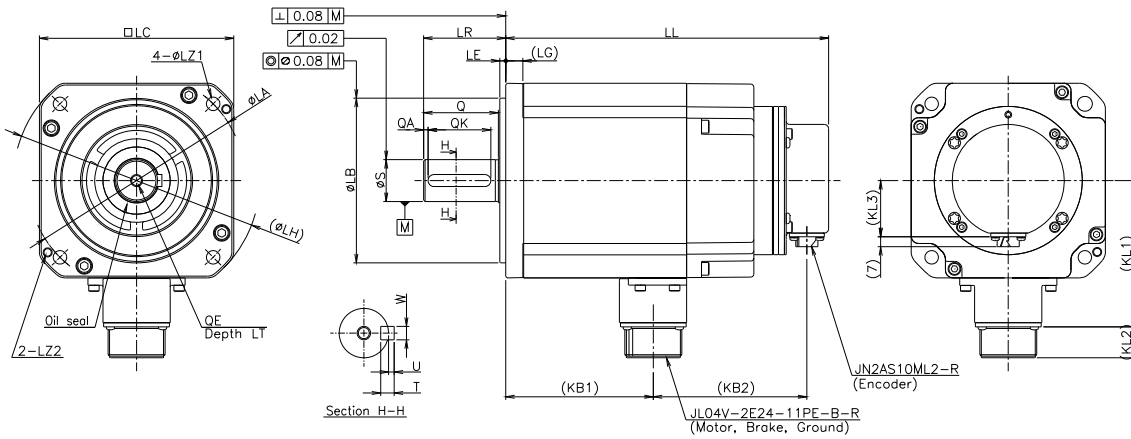

Servo motor model number	Battery backup method absolute encoder Absolute encoder for incremental system						Incremental encoder						LG	KL1	KL2	LA
	Without Brake			With Brake			Without Brake			With Brake						
	LL	KB2	KL3	LL	KB2	KL3	LL	KB2	KL3	LL	KB2	KL3				
R2AA13200△□◇	171	57	38	216	103	38	185	64	65	230	110	65	12	98	21	145

Servo motor model number	LB	LE	LH	LC	LZ1	LZ2	LR	S	Q	QA	QK	W	T	U	KB1	QE	LT
R2AA13200△□◇	0 110-0.035	4	165	13	9	M6	55	0	50	3	42	0	7	3	99	M8	25
				0				28-0.013				8-0.036					

✓ Please contact us for the dimensions for the encoder below. Battery less absolute encoder [RA035C]

Materials: Dimension

[R2 □180]

R2 motor, flange size 180mm 3.5kW to 7.5Kw

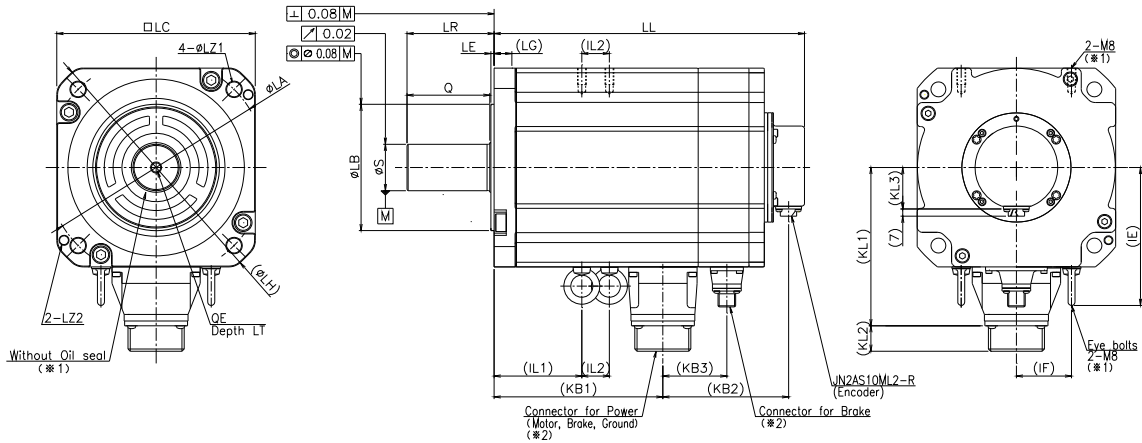

Servo motor model number	Battery backup method absolute encoder Absolute encoder for incremental system								Incremental encoder														
	Without Brake				With Brake				Without Brake				With Brake										
	LL	KB2	KB3	KL3	LL	KB2	KB3	KL3	LL	KB2	KB3	KL3	LL	KB2	KB3	KL3	LG	KL1	KL2	LA	LB	LE	LH
R2AA18350△□◇	155	48	-	-	204	97	-	-	172	59	-	-	221	108	-	-	16	123	21	200	0	3	230
R2AA18450△□◇	172	-	-	38	221	-	-	38	189	-	-	65	238	-	-	65	19	144	22	200	114.3	-0.035	3
R2AA18550△□◇	228	-	-	-	281	114	58	-	242	-	-	-	295	121	58	-	19	144	22	200	114.3	-0.035	3
R2AA18750△□◇	273	59	-	-	336	124	68	-	287	-	-	-	350	131	68	-	19	144	22	200	114.3	-0.035	3

Servo motor model number	LC	LZ1	LZ2	LR	S	Q	KB1	QE	LT	IE	IF	IL1	IL2	Model NO., of connector for power line	Model NO., of connector for brake line
R2AA18350△□◇	180	13.5	M8	65	0	60	92	M8	25	123	50	50	20	JL04V-2E24-11PE-B-R	-
35-0.016					109		57			20					
0				153	63	41	JL04V-2E32-17PE-B-R	JL04V-2E10SL-3PE-B-R							
42-0.016				198	86	86									

✓ Please contact us for the dimensions for the encoder below. Battery less absolute encoder [RA035C]

- Note1) No eyebolts are supplied with R2AA18350 motor with no brake.
- Note2) Connector for powering line is used in common with braking line.

R2 motor, flange size 180mm 11kW

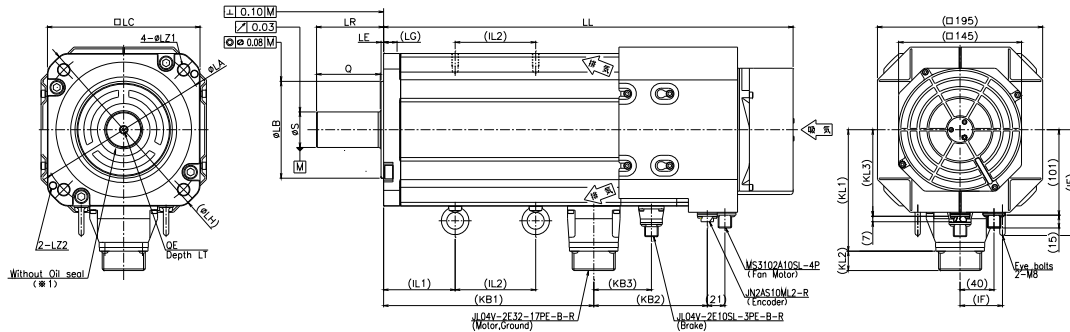

Servo motor model number	Battery backup method absolute encoder Absolute encoder for incremental system								Incremental encoder											
	Without Brake				With Brake				Without Brake				With Brake							
	LL	KB2	KB3	KL3	LL	KB2	KB3	KL3	LL	KB2	KB3	KL3	LL	KB2	KB3	KL3	LG	KL1	KL2	LA
R2AA1811K△□◇	385	59	-	102	478	154	83	102	385	-	66	102	478	161	83	102	19	144	22	200

Servo motor model number	LB	LE	LH	LC	LZ1	LZ2	LR	S	Q	KB1	QE	LT	IE	IF	IL1	IL2		
R2AA1811K△□◇	0	114.3-0.035	3	230	180	13.5	M8	79	0	42-0.016	75	223	M10	25	123	50	63	111

✓ Please contact us for the dimensions for the encoder below. Battery less absolute encoder [RA035C]

Materials: Dimension

[R2 □220]

R2 motor, flange size 220mm 3.5kW to 5kW

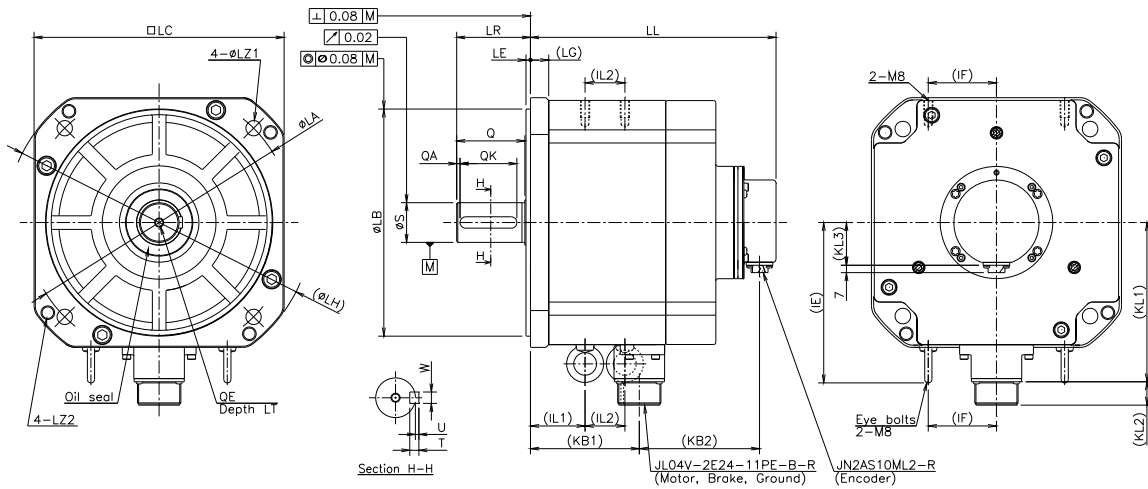

Servo motor model number	Battery backup method absolute encoder Absolute encoder for incremental system						Incremental encoder						LG	KL1	KL2	KL3	LA	LB	LE	LH
	Without Brake			With Brake			Without Brake			With Brake										
	LL	KB2	KL3	LL	KB2	KL3	LL	KB2	KL3	LL	KB2	KL3								
R2AA22350 Δ □◇	145	52	38	198	106	38	159	59	65	212	113	65	16	142	21	38	235	0	4	270
R2AA22500 Δ □◇	163			216			177			230								200-0.046		

Servo motor model number	LC	LZ1	LZ2	LR	S	Q	QA	QK	W	T	U	KB1	QE	LT	IE	IF	IL1	IL2
R2AA22350 Δ □◇	220	13.5	M12	65	0	60	3	50	0	8	3	78	M8	25	142	60	48	18
R2AA22500 Δ □◇					35-0.016				10-0.036			96						35

✓ Please contact us for the dimensions for the encoder below. Battery less absolute encoder [RA035C]

Materials: Dimension

[Q2 □100 to □180]

Q1 motor, flange size 100mm, 120mm, 130mm, and 180mm

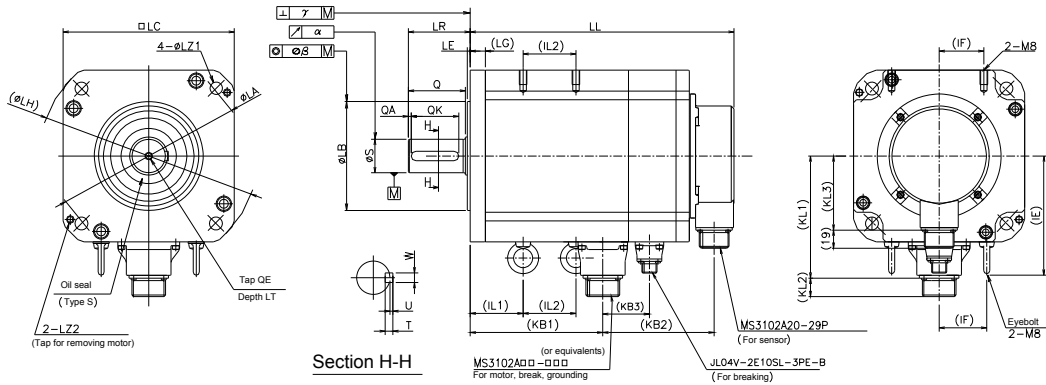

Servo motor model number	Wire-saving incremental encoder					Battery backup absolute encoder					Connector, Note1)		[PP0 62]	[PA0 35C]	LA	LB			
	No brake		With brake			No brake		With brake			Motor earth	Brake (With brake-motor only, Note2)							
	LL	KB2	LL	KB2	KB3	LL	KB2	LL	KB2	KB3	MS3102A	JL04V-2E	LG	KL1	KL2	KL3	KL3		
Q1AA10200△□◇	234	80	269	116	51	243	90	279	125	51	20-15P	10SL-3PEB	10	78	19	63	63	115	0 95-0.035
Q1AA10250△□◇	259		294			268		304											
Q1AA12200△□◇	205	72	241	108	45	220	87	256	123	45	24-11P	10SL-3PE-B	12	93	21	67	63	135/ 145	0 110-0.035
Q1AA12300△□◇	242		278			257		293											
Q1AA13300△□◇	205		254			220		270											
Q1AA13400△□◇	232	67	281	117	-	247	84	297	134	-	24-11P		12	98	21	80	63	145	0 110-0.035
Q1AA13500△□◇	269		318			284		334											
Q1AA18450△□◇	288	67	338	117	-	304	84	354	134	-	24-11P		16	123	21				0
Q1AA18750△□◇	384	72	434	122	54	400	89	450	139	54	32-17P	10SL-3PE-B	19	144	22	80	63	200	0 114.3-0.035

Servo motor model number	LE	LH	LC	LZ1	LZ2	LR	S	Q	QA	QK	W	T	U	KB1	α	β	γ	QE	LT	IE	IF	IL1	IL2
Q1AA10200△□◇	3	130	100	9	-	45	0	40	3	32	0	6	2.5	134	0.02	0.08	0.08	M6	20	-	-	-	-
Q1AA10250△□◇							22-0.013				6-0.030			159									
Q1AA12200△□◇	3	162	120	9	-	45	0	40	3	32	0	6	2.5	113	0.02	0.08	0.08	M6	20	-	-	-	-
Q1AA12300△□◇							22-0.013				6-0.030												
Q1AA13300△□◇	4	165	130	9	M6	55	0	50	3	42	0	7	3	117	0.02	0.08	0.08	M8	25	-	-	-	-
Q1AA13400△□◇							28-0.013				8-0.036			144									
Q1AA13500△□◇							28-0.013				8-0.036			181									
Q1AA18450△□◇	3	230	180	13.5	M8	65	0	60	3	50	0	8	3	200	0.02	0.08	0.08	M8	25	124	50	93	50
Q1AA18750△□◇						35-0.016	10-0.036							291									

Note1) Use waterproof connector for receptacle plug when compliance with IP67 required, as connector is waterproof when fit.

Note2) All the brake connectors are JL04V-2E70SL-3PE-B, when DC24V-brake conforms to CE.

Materials: Dimension

[Q2 □130 to □220]

Q2 motor, flange size 130mm, 180mm, and 220mm

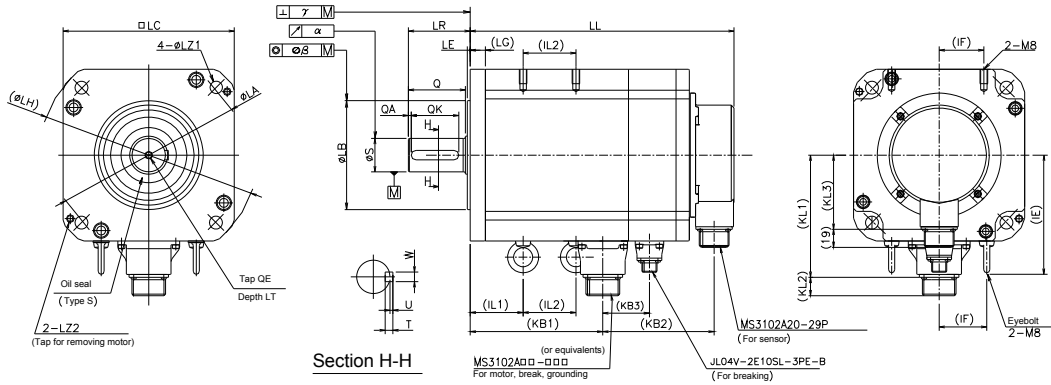

Servo motor model number	Wire-saving incremental encoder					Battery backup absolute encoder					Connector, Note1)		[PP 062]	[PA03 5C]	LA	LB			
	No brake		With brake			No brake		With brake			Motor earth	Brake (with-brake motor only, Note2)							
	LL	KB2	LL	KB2	KB3	LL	KB2	LL	KB2	KB3	MS3102A	JL04V-2E	LG	KL1	KL2	KL3	KL3	LA	LB
Q2AA13200△□◇	186	67	226	107	-	201	84	241	124	-	24-11P		12	98	21	80	63	145	0 110-0.035
Q2AA18200△□◇	171	67	221	117	-	186	84	236	134	-	24-11P		16	123	21	80	63	200	0 114.3-0.035
Q2AA18350△□◇	203		253			218		268											
Q2AA18450△□◇	218		268			234		284											
Q2AA18550△□◇	282	72	332	122	54	298	89	348	139	54	32-17P	10SL-3PE-EB	19	144	22	80	63	200	0 114.3-0.035
Q2AA18750△□◇	332		382			348		398											
Q2AA22550△□◇	252	82	309	140	82	265	97	323	155	82	24-11P	10SL-3PE-EB	19	141	21	80	63	235	0 200-0.046
Q2AA22700△□◇	310		368			323		381											
Q2AA2211K△□◇	335	73	393	131	61	355	94	406	145	61	32-17P	10SL-3PE-EB	19	162	22	80	63	235	0 200-0.046
Q2AA2215K△□◇	394		452			414		465											

Servo motor model number	LE	LH	LC	LZ1	LZ2	LR	S	Q	QA	QK	W	T	U	KB1	α	β	γ	QE	LT	IE	IF	IL1	IL2
Q2AA13200△□◇	4	165	130	9	M6	55	0 28-0.013	50	3	42	0 8-0.036	7	3	98	0.02	0.08	0.08	M8	25	-	-	-	-
Q2AA18200△□◇	3	230	180	13.5	M8	65	0 35-0.016	60	3	50	0 10-0.036	8	3	83	0.02	0.08	0.08	M8	25	124	50	61	20 35
Q2AA18350△□◇														115									
Q2AA18450△□◇														130									
Q2AA18550△□◇	3	230	180	13.5	M8	79	0 42-0.016	75	3	67	0 12-0.043	8	3	189	0.02	0.08	0.08	M10	25	124	50	85	50
Q2AA18750△□◇														239									100
Q2AA22550△□◇	4	270	220	13.5	M10	79	0 55-0.019	75	3	67	0 16-0.043	10	4	149	0.03	0.08	0.10	M10	25	142	60	55	50
Q2AA22700△□◇														207									110
Q2AA2211K△□◇	4	270	220	13.5	M10	79	0 55-0.019	75	3	67	0 16-0.043	10	4	241	0.03	0.08	0.10	M10	25	142	60	69	120
Q2AA2215K△□◇														300									180

Note1) Use waterproof connector for receptacle plug when compliance with IP67 required, as connector is waterproof when fit.

Note2) All the brake connectors are JL04V-2E70SL-3PE-B, when DC24V-brake conforms to CE.

Materials

Servo motor data sheet [Characteristics table]

Three-phase AC200V Input specification

Servo Motor model Q1AA			04003D	04005D	04010D	06020D	06040D	07075D
Servo Amplifier model RS1□			01*	01*	01*	01*	03*	03*
*Rated output	P_R	kW	0.03	0.05	0.1	0.2	0.4	0.75
*Rated speed	N_R	min^{-1}	3000	3000	3000	3000	3000	3000
*Maximum speed	N_{max}	min^{-1}	5000	5000	5000	5000	5000	5000
*Rated torque	T_R	$\text{N}\cdot\text{m}$	0.098	0.159	0.318	0.637	1.27	2.38
*Continuous stall torque	T_S	$\text{N}\cdot\text{m}$	0.108	0.159	0.318	0.637	1.27	2.38
*Peak armature current at stall	T_P	$\text{N}\cdot\text{m}$	0.322	0.477	0.955	1.91	3.82	7.16
*Rated armature current	I_R	Arms	0.49	0.80	1	1.5	2.9	4.5
*Peak armature current at stall	I_S	Arms	0.53	0.80	1	1.5	2.9	4.5
*Peak armature current	I_P	Arms	2.2	2.9	3.6	5.8	10.5	15
Torque constant	K_T	$\text{N}\cdot\text{m}/\text{Arms}$	0.220	0.23	0.360	0.49	0.510	0.61
Voltage constant for each phase	$K_{E\Phi}$	$\text{mV}/\text{min}^{-1}$	7.68	8.0	12.6	17.2	17.8	21.4
Phase resistance	R_Φ	Ω	15	8.1	7.6	2.5	1.3	0.63
*Rated power rate	Q_R	kW/s	9.60	18.8	43.4	28.7	65.3	89.6
Inertia (including Wiring INC)	J_M	$\text{kg}\cdot\text{m}^2$ ($\text{GD}^2/4$) $\times 10^{-4}$	0.01	0.0134	0.0233	0.141	0.247	0.636
Aluminium plate		mm	t6×250	t6×250	t6×250	t12×250	t12×250	t12×250

Servo Motor model Q1AA			10100D	10150D	10200D	10250D	12100D	12200D
Servo Amplifier model RS1□			05*	05*	10*	10*	05*	10*
*Rated output	P_R	kW	1	1.5	2	2.5	1	2
*Rated speed	N_R	min^{-1}	3000	3000	3000	3000	3000	3000
*Maximum speed	N_{max}	min^{-1}	5000	4500	5000	5000	5000	5000
*Rated torque	T_R	$\text{N}\cdot\text{m}$	3.19	4.79	6.37	7.97	3.19	6.37
*Continuous stall torque	T_S	$\text{N}\cdot\text{m}$	3.92	4.9	7.36	8.82	3.92	7.36
*Peak armature current at stall	T_P	$\text{N}\cdot\text{m}$	10.5	14.7	19.6	24.4	11	21
*Rated armature current	I_R	Arms	6.5	8.2	15.9	16.6	6.2	14.3
*Peak armature current at stall	I_S	Arms	7.8	8.2	18	17.2	7.5	16.2
*Peak armature current	I_P	Arms	24.5	26.5	55	55	24.5	53
Torque constant	K_T	$\text{N}\cdot\text{m}/\text{Arms}$	0.55	0.705	0.470	0.587	0.578	0.534
Voltage constant for each phase	$K_{E\Phi}$	$\text{mV}/\text{min}^{-1}$	19.3	24.6	16.4	20.5	20.2	18.6
Phase resistance	R_Φ	Ω	0.34	0.272	0.0860	0.104	0.190	0.07
*Rated power rate	Q_R	kW/s	78.9	143	189	240	45.2	93
Inertia (including Wiring INC)	J_M	$\text{kg}\cdot\text{m}^2$ ($\text{GD}^2/4$) $\times 10^{-4}$	1.29	1.61	2.15	2.65	2.25	4.37
Aluminium plate		mm	t20×400	t20×400	t20×470	t20×470	t20×400	t20×470

Servo Motor model Q1AA			12300D	13300D	13400D	13500D	18450M	18750H
Servo Amplifier model RS1□			10*	10*	15*	15*	15*	30*
*Rated output	P_R	kW	3	3	4	5	4.5	7.5
*Rated speed	N_R	min^{-1}	3000	3000	3000	3000	1500	1500
*Maximum speed	N_{max}	min^{-1}	5000	4500	4500	4500	1500	3000
*Rated torque	T_R	$\text{N}\cdot\text{m}$	9.55	9.5	12.7	15.7	28.5	48
*Continuous stall torque	T_S	$\text{N}\cdot\text{m}$	11	10.8	14.7	18.1	31.6	55
*Peak armature current at stall	T_P	$\text{N}\cdot\text{m}$	31	28.4	39.2	47.6	105	125
*Rated armature current	I_R	Arms	16.2	16.7	23.4	25.8	20	55
*Peak armature current at stall	I_S	Arms	17.3	17.6	26.4	27.5	22.2	60
*Peak armature current	I_P	Arms	55	55	83	83	83	155
Torque constant	K_T	$\text{N}\cdot\text{m}/\text{Arms}$	0.73	0.693	0.612	0.724	1.71	0.91
Voltage constant for each phase	$K_{E\Phi}$	$\text{mV}/\text{min}^{-1}$	25.4	24.2	21.4	25.3	59.6	31.7
Phase resistance	R_Φ	Ω	0.082	0.087	0.048	0.0461	0.129	0.021
*Rated power rate	Q_R	kW/s	143	184	251	291	295	443
Inertia (including Wiring INC)	J_M	$\text{kg}\cdot\text{m}^2$ ($\text{GD}^2/4$) $\times 10^{-4}$	6.4	4.92	6.43	8.47	27.5	52
Aluminium plate		mm	t20×470	t20×470	t20×470	t20×540	t20×540	t20×540

- Constants are values at the time of installing on the aluminum board in the table. They indicate 'thickness'×'side of square'.
- Items with "*" and velocity – torque characteristics indicate values after temperature rise saturation. The others indicate values at 20°C. Each value indicates TYP.

AC100V Input specification

Servo Motor model Q1EA			04003D	04005D	04010D	06020D
Servo Amplifier model RS1□			01*	01*	01*	03*
*Rated output	P_R	kW	0.03	0.05	0.1	0.2
*Rated speed	N_R	min^{-1}	3000	3000	3000	3000
*Maximum speed	N_{max}	min^{-1}	5000	5000	5000	5000
*Rated torque	T_R	$\text{N}\cdot\text{m}$	0.098	0.159	0.318	0.637
*Continuous stall torque	T_S	$\text{N}\cdot\text{m}$	0.108	0.159	0.318	0.637
*Peak armature current at stall	T_P	$\text{N}\cdot\text{m}$	0.322	0.477	0.955	1.91
*Rated armature current	I_R	Arms	0.9	1.9	2.2	4.5
*Peak armature current at stall	I_S	Arms	0.95	1.9	2.2	4.5
*Peak armature current	I_P	Arms	4	7	7.9	15.5
Torque constant	K_T	$\text{N}\cdot\text{m}/\text{Arms}$	0.115	0.096	0.176	0.161
Voltage constant for each phase	$K_{E\Phi}$	$\text{mV}/\text{min}^{-1}$	4.03	3.3	6.13	5.63
Phase resistance	R_Φ	Ω	4.28	1.4	2.2	0.33
*Rated power rate	Q_R	kW/s	9.6	18.8	43.5	28.7
Inertia (including Wiring INC)	J_M	$\text{kg}\cdot\text{m}^2$ ($\text{GD}^2/4$) $\times 10^{-4}$	0.01	0.0134	0.0233	0.141
Aluminium plate		mm	t6×305	t6×305	t6×305	t6×305

- Constants are values at the time of installing on the aluminum board in the table. They indicate 'thickness'×'side of square'.
- Items with * and velocity-torque characteristics indicate values after temperature rise saturation. The others indicate values at 20°C. Each value indicates TYP.

Materials

Servo motor data sheet [Characteristics table]

Three-phase AC200V Input specification

Servo Motor model Q2AA			04006D	04010D	05005D	05010D	05020D	07020D	07030D
Servo Amplifier model RS1□			01*	01*	01*	01*	01*	01*	01*
*Rated output	P_R	kW	0.06	0.1	0.05	0.1	0.2	0.2	0.3
*Rated speed	N_R	min^{-1}	3000	3000	3000	3000	3000	3000	3000
*Maximum speed	N_{max}	min^{-1}	5000	5000	5000	5000	5000	5000	5000
*Rated torque	T_R	$\text{N}\cdot\text{m}$	0.191	0.318	0.159	0.318	0.637	0.637	0.955
*Continuous stall torque	T_S	$\text{N}\cdot\text{m}$	0.216	0.353	0.167	0.353	0.686	0.686	0.98
*Peak armature current at stall	T_P	$\text{N}\cdot\text{m}$	0.65	1	0.518	1.06	2.05	2.1	3.4
*Rated armature current	I_R	Arms	0.67	1.1	0.86	1.1	1.6	2.1	2.1
*Peak armature current at stall	I_S	Arms	0.67	1.2	0.88	1.2	1.7	2.2	2.5
*Peak armature current	I_P	Arms	2.7	3.6	3.3	4.3	5.9	7.5	7.9
Torque constant	K_T	$\text{N}\cdot\text{m}/\text{Arms}$	0.314	0.325	0.21	0.33	0.435	0.34	0.519
Voltage constant for each phase	$K_{E\phi}$	$\text{mV}/\text{min}^{-1}$	10.97	11.34	7.26	11.4	15.2	11.8	18.1
Phase resistance	R_ϕ	Ω	11.3	6.77	4.72	4.05	3.24	1.88	2.22
*Rated power rate	Q_R	kW/s	6.46	11.8	3.78	7.78	16.2	10.6	20.3
Inertia (including Wiring INC)	J_M	$\text{kg}\cdot\text{m}^2$ (GD2/4) $\times 10^{-4}$	0.057	0.086	0.067	0.13	0.25	0.38	0.45
Aluminium plate		mm	t6×250	t6×250	t6×250	t6×305	t6×305	t6×305	t6×305

Servo Motor model Q2AA			07040D	07050D	08050D	08075D	08100D	10100H	10150H
Servo Amplifier model RS1□			03*	03*	03*	05*	05*	05*	05*
*Rated output	P_R	kW	0.4	0.5	0.5	0.75	1	1	1.5
*Rated speed	N_R	min^{-1}	3000	3000	3000	3000	3000	2000	2000
*Maximum speed	N_{max}	min^{-1}	5000	5000	5000	5000	5000	3500	3000
*Rated torque	T_R	$\text{N}\cdot\text{m}$	1.273	1.59	1.589	2.387	3.18	5	7.2
*Continuous stall torque	T_S	$\text{N}\cdot\text{m}$	1.372	1.85	1.96	2.941	3.92	6	8
*Peak armature current at stall	T_P	$\text{N}\cdot\text{m}$	4.1	5.2	6.56	9	12.5	16.6	20.5
*Rated armature current	I_R	Arms	3.0	4.3	3.7	5.9	6	6.8	8.6
*Peak armature current at stall	I_S	Arms	3.1	5.0	4.3	7	6.9	8.1	9.4
*Peak armature current	I_P	Arms	12	15	15	23.7	25	24.5	25.5
Torque constant	K_T	$\text{N}\cdot\text{m}/\text{Arms}$	0.482	0.442	0.52	0.441	0.59	0.814	0.94
Voltage constant for each phase	$K_{E\phi}$	$\text{mV}/\text{min}^{-1}$	16.8	15.4	18.1	15.4	20.5	28.4	32.7
Phase resistance	R_ϕ	Ω	1.26	0.8	0.800	0.358	0.410	0.477	0.34
*Rated power rate	Q_R	kW/s	21.6	27.3	19.4	27.5	37.0	46.0	65
Inertia (including Wiring INC)	J_M	$\text{kg}\cdot\text{m}^2$ (GD2/4) $\times 10^{-4}$	0.75	0.85	1.3	2.07	2.7	5.4	8.0
Aluminium plate		mm	t6×305	t6×305	t6×305	t6×305	t20×305	t20×400	t20×400

Servo Motor model Q2AA			13050H	13100H	13150H	13200H	18200H	18350H	18450H
Servo Amplifier model RS1□			03*	05*	05*	10*	10*	15*	15*
*Rated output	P_R	kW	0.5	1.0	1.5	2	2	3.5	4.5
*Rated speed	N_R	min^{-1}	2000	2000	2000	2000	2000	2000	2000
*Maximum speed	N_{max}	min^{-1}	3500	3000	3500	3500	3500	3500	3000
*Rated torque	T_R	$\text{N}\cdot\text{m}$	2.5	5	7.5	9.55	9.5	16.7	21.5
*Continuous stall torque	T_S	$\text{N}\cdot\text{m}$	3	6	9	12	12	21.1	27.1
*Peak armature current at stall	T_P	$\text{N}\cdot\text{m}$	7.1	15	20.3	30.5	31	55	70
*Rated armature current	I_R	Arms	4.6	7	8.7	13.1	15	22.6	24
*Peak armature current at stall	I_S	Arms	5.2	8.3	10.2	16.3	18	28	29
*Peak armature current	I_P	Arms	15	23.7	26.5	48	55	83	81
Torque constant	K_T	$\text{N}\cdot\text{m}/\text{Arms}$	0.607	0.803	0.981	0.822	0.75	0.840	1.04
Voltage constant for each phase	$K_{E\phi}$	$\text{mV}/\text{min}^{-1}$	21.2	28.0	34.2	29	25.9	29.3	36.4
Phase resistance	R_ϕ	Ω	0.442	0.276	0.266	0.128	0.075	0.048	0.044
*Rated power rate	Q_R	kW/s	22.3	46	64	78	45.7	73	84
Inertia (including Wiring INC)	J_M	$\text{kg}\cdot\text{m}^2$ (GD2/4) $\times 10^{-4}$	2.8	5.4	7.94	12	20	38	55
Aluminium plate		mm	t20×305	t20×400	t20×400	t20×470	t20×470	t20×470	t20×470

- Constants are values at the time of installing on the aluminum board in the table. They indicate 'thickness'×'side of square.'
- Items with "*" and velocity-torque characteristics indicate values after temperature rise saturation. The others indicate values at 20°C. Each value indicates TYP.

Materials

Servo motor data sheet [Characteristics table]

Servo Motor model Q2AA			18550R	22550B	22700S	18550H	18750L	2211KV	2215KV
Servo Amplifier model RS1□			15*	15*	15*	30*	30*	30*	30*
*Rated output	P_R	kW	5.5	5.5	7	5.5	7.5	11	15
*Rated speed	N_R	min-1	1500	1500	1000	1500	1500	1500	1500
*Maximum speed	N_{max}	min-1	2500	2000	1000	3000	3000	2000	2000
*Rated torque	T_R	N·m	35	35	67	35	48	70	95.5
*Continuous stall torque	T_S	N·m	37.3	42	70	37.3	54.9	80	95.5
*Peak armature current at stall	T_P	N·m	88	90	150	95	137	176	215
*Rated armature current	I_R	Arms	32.2	30	34	47	52	60	66
*Peak armature current at stall	I_S	Arms	33.7	35.1	34	47	57	66	66
*Peak armature current	I_P	Arms	83	79.7	83	155	160	155	157
Torque constant	K_T	N·m/Arms	1.24	1.32	2.13	0.830	1.03	1.29	1.54
Voltage constant for each phase	$K_{E\Phi}$	mV/min-1	43.2	46.0	74.5	29.0	36.0	45.1	53.6
Phase resistance	R_Φ	Ω	0.039	0.0464	0.057	0.018	0.017	0.015	0.016
*Rated power rate	Q_R	kW/s	180	129	243	168	240	260	360
Inertia (including Wiring INC)	J_M	kg·m2 (GD2/4) ×10-4	69	95	185	73	95	186	255
Aluminium plate		mm	t20×540	t20×540	t20×540	t20×540	t20×540	t20×540	t20×540

AC100V Input specification

Servo Motor model Q2EA			04006D	04010D	05005D	05010D	05020D	07020D
Servo Amplifier model RS1□			01*	01*	01*	01*	03*	03*
*Rated output	P_R	kW	0.06	0.1	0.05	0.1	0.2	0.2
*Rated speed	N_R	min-1	3000	3000	3000	3000	3000	3000
*Maximum speed	N_{max}	min-1	5000	5000	5000	5000	5000	5000
*Rated torque	T_R	N·m	0.191	0.318	0.159	0.318	0.637	0.637
*Continuous stall torque	T_S	N·m	0.216	0.353	0.167	0.353	0.686	0.686
*Peak armature current at stall	T_P	N·m	0.65	1	0.518	1.03	2.1	2.1
*Rated armature current	I_R	Arms	1.9	2.0	1.5	2.1	3.9	4.4
*Peak armature current at stall	I_S	Arms	1.9	2.2	1.5	2.3	4.1	4.6
*Peak armature current	I_P	Arms	7.9	7	5.6	7.9	15.5	15.5
Torque constant	K_T	N·m/Arms	0.117	0.188	0.12	0.169	0.184	0.162
Voltage constant for each phase	$K_{E\Phi}$	mV/min-1	4.09	6.55	4.2	5.9	6.41	5.67
Phase resistance	R_Φ	Ω	1.5	1.9	1.8	1.22	0.64	0.5
*Rated power rate	Q_R	kW/s	6.46	11.8	3.78	7.8	16.2	10.6
Inertia (including Wiring INC)	J_M	kg·m2 (GD2/4) ×10-4	0.057	0.086	0.067	0.13	0.25	0.38
Aluminium plate		mm	t6×305	t6×305	t6×305	t6×305	t6×305	t6×305

- Constants are values at the time of installing on the aluminum board in the table. They indicate 'thickness'×'side of square'.
- Items with "*" and velocity-torque characteristics indicate values after temperature rise saturation. The others indicate values at 20°C. Each value indicates TYP.

Materials

Servo motor data sheet [Characteristics table]

Servo Motor model	R2AA		04003F	04005F	04010F	06010F	06020F	06040H	08020F
Servo Amplifier model	RS1□		01*	01*	01*	01*	01*	01*	01*
*Rated output	P_R	kW	0.03	0.05	0.1	0.1	0.2	0.4	0.2
*Rated speed	N_R	min^{-1}	3000	3000	3000	3000	3000	3000	3000
*Maximum speed	N_{max}	min^{-1}	6000	6000	6000	6000	6000	3000	6000
*Rated torque	T_R	$\text{N}\cdot\text{m}$	0.098	0.159	0.318	0.318	0.637	1.27	0.637
*Continuous stall torque	T_S	$\text{N}\cdot\text{m}$	0.108	0.167	0.318	0.353	0.686	1.37	0.686
*Peak armature current at stall	T_P	$\text{N}\cdot\text{m}$	0.37	0.59	1.18	1.13	2.2	4.8	2.2
*Rated armature current	I_R	Arms	0.51	0.67	0.81	0.86	1.5	1.7	1.5
*Peak armature current at stall	I_S	Arms	0.56	0.69	0.81	0.86	1.6	1.8	1.5
*Peak armature current	I_P	Arms	2.15	2.8	3.3	3.5	5.6	7.1	4.8
Torque constant	K_T	$\text{N}\cdot\text{m}/\text{Arms}$	0.201	0.246	0.424	0.375	0.476	0.816	0.516
Voltage constant for each phase	$K_{E\Phi}$	$\text{mV}/\text{min}^{-1}$	7	8.6	14.8	13.1	16.6	28.5	18.0
Phase resistance	R_Φ	Ω	12	9	9.3	4.8	2.7	3.3	2.3
*Rated power rate	Q_R	kW/s	3.9	6.7	16	8.6	19	39	8
Inertia (including Wiring INC)	J_M	$\text{kg}\cdot\text{m}^2$ ($\text{GD}^2/4$) $\times 10^{-4}$	0.028	0.0409	0.066	0.120	0.222	0.415	0.523
Aluminium plate		mm	t6×250	t6×250	t6×250	t6×250	t6×250	t6×250	t6×250

Servo Motor model	R2AA		06040F	08040F	08075F	B8075F	B8100H	B8100F	10075F
Servo Amplifier model	RS1□		03*	03*	03*	05*	03*	05*	03*
*Rated output	P_R	kW	0.4	0.4	0.75	0.75	1.0	1.0	0.75
*Rated speed	N_R	min^{-1}	3000	3000	3000	3000	3000	3000	3000
*Maximum speed	N_{max}	min^{-1}	6000	6000	6000	6000	3000	6000	6000
*Rated torque	T_R	$\text{N}\cdot\text{m}$	1.27	1.27	2.39	2.38	3.18	3.18	2.39
*Continuous stall torque	T_S	$\text{N}\cdot\text{m}$	1.37	1.37	2.55	2.94	3.92	3.92	2.55
*Peak armature current at stall	T_P	$\text{N}\cdot\text{m}$	4.8	4.4	8.5 (Note1)	11.0	11.6	14.3	8.6
*Rated armature current	I_R	Arms	2.8	2.6	4.6	4.7	4.6	6.0	4.4
*Peak armature current at stall	I_S	Arms	2.8	2.6	4.6	5.5	4.7	6.8	4.6
*Peak armature current	I_P	Arms	10.8	8.9	15.5	23.7	15.5	25.7	15.5
Torque constant	K_T	$\text{N}\cdot\text{m}/\text{Arms}$	0.524	0.559	0.559	0.547	0.825	0.582	0.582
Voltage constant for each phase	$K_{E\Phi}$	$\text{mV}/\text{min}^{-1}$	18.3	19.5	19.5	19.1	28.8	20.3	20.3
Phase resistance	R_Φ	Ω	1.36	0.93	0.4	0.62	0.85	0.44	0.69
*Rated power rate	Q_R	kW/s	39	16	31	35	42	42	29
Inertia (including Wiring INC)	J_M	$\text{kg}\cdot\text{m}^2$ ($\text{GD}^2/4$) $\times 10^{-4}$	0.415	1.043	1.823	1.643	2.383	2.383	2.003
Aluminium plate		mm	t6×250	t6×250	t6×250	t6×305	t6×305	t12×305	t6×305

Servo Motor model	R2AA		10100F	13050H	13050D	13120B	13120D	13120L	13180H
Servo Amplifier model	RS1□		05*	03*	03*	03*	05*	05*	05*
*Rated output	P_R	kW	1.0	0.55	0.55	1.2	1.2	1.2	1.8
*Rated speed	N_R	min^{-1}	3000	2000	2000	2000	2000	2000	2000
*Maximum speed	N_{max}	min^{-1}	6000	3500	5000	2000	5000	3000	3500
*Rated torque	T_R	$\text{N}\cdot\text{m}$	3.18	2.6	2.6	5.7	5.7	5.7	8.6
*Continuous stall torque	T_S	$\text{N}\cdot\text{m}$	3.92	3.0	2.6	6.0	6.0	6.0	10.0
*Peak armature current at stall	T_P	$\text{N}\cdot\text{m}$	14.3	9.0	7.0	16.0	16	20.0	22.0
*Rated armature current	I_R	Arms	5.7	4.2	5.2	5.2	9.1	7.6	11.0
*Peak armature current at stall	I_S	Arms	6.8	4.6	5.2	5.2	9.3	8.4	11.8
*Peak armature current	I_P	Arms	25.7	15.5	15.5	15.5	25.4	26.5	26.5
Torque constant	K_T	$\text{N}\cdot\text{m}/\text{Arms}$	0.584	0.67	0.53	1.09	0.65	0.77	0.89
Voltage constant for each phase	$K_{E\Phi}$	$\text{mV}/\text{min}^{-1}$	20.4	23.5	18.5	37.8	22.7	27.0	31.1
Phase resistance	R_Φ	Ω	0.35	0.65	0.39	0.64	0.23	0.35	0.23
*Rated power rate	Q_R	kW/s	29	22	22	54	54	54	82
Inertia (including Wiring INC)	J_M	$\text{kg}\cdot\text{m}^2$ ($\text{GD}^2/4$) $\times 10^{-4}$	3.5	3.1	3.1	6.0	6.0	6.0	9.0
Aluminium plate		mm	t12×305	t20×305	t20×305	t20×400	t20×400	t20×400	t20×470

- Constants are values at the time of installing on the aluminum board in the table. They indicate 'thickness'×'side of square.'
- Items with "*" and velocity-torque characteristics indicate values after temperature rise saturation. The others indicate values at 20°C. Each value indicates TYP.

Note1) Peak torque at stall 8.5 [N·m] is the value in the case of 3-phase 200V. The value in the case of single-phase 200V is 7 [N·m]. Peak armature current 15.5 [Arms] is the value in the case of 3-phase 200V. The value in the case of single-phase 200V is 13.1 [Arms].

Materials

Servo motor data sheet [velocity-torque characteristics]

Servo Motor model R2AA			13180D	13200L	13200D	18350L	18350D	18450H	18550R
Servo Amplifier model RS1□			10*	05*	10*	10*	15*	15*	15*
*Rated output	P_R	kW	1.8	2.0	2.0	3.5	3.5	4.5	5.5
*Rated speed	N_R	min^{-1}	2000	2000	2000	2000	2000	2000	1500
*Maximum speed	N_{max}	min^{-1}	5000	3000	5000	3000	4000	3500	2500
*Rated torque	T_R	$\text{N}\cdot\text{m}$	8.6	9.5	9.5	17.0	17.0	21.5	35.0
*Continuous stall torque	T_S	$\text{N}\cdot\text{m}$	10.0	12.0	12	22.0	22.0	30.0	37.3
*Peak armature current at stall	T_P	$\text{N}\cdot\text{m}$	25.0	24.0	30	49.0	60.0	75.0	90.0
*Rated armature current	I_R	Arms	15.6	11.0	14.3	19.1	21.7	23.7	31.6
*Peak armature current at stall	I_S	Arms	17.3	12.0	17.5	23.7	27.0	31.7	32.9
*Peak armature current	I_P	Arms	43.0	26.5	45.5	55.0	83.0	83.0	83.0
Torque constant	K_T	$\text{N}\cdot\text{m}/\text{Arms}$	0.63	0.97	0.7	19.1	21.7	1.02	1.23
Voltage constant for each phase	$K_{E\Phi}$	$\text{mV}/\text{min}^{-1}$	21.8	33.7	24.3	23.7	27.0	35.6	42.8
Phase resistance	R_Φ	Ω	0.13	0.22	0.11	55.0	83.0	0.065	0.059
*Rated power rate	Q_R	kW/s	82	74	74	72	72	92	180
Inertia (including Wiring INC)	J_M	$\text{kg}\cdot\text{m}^2$ ($\text{GD}^2/4$) $\times 10^{-4}$	9.0	12.2	12.203	40	40	50	68
Aluminium plate		mm	t20×470	t20×470	t20×470	t20×470	t20×470	t20×470	t20×540

Servo Motor model R2AA			18550H	18750H	1811KR	22350L	22500L
Servo Amplifier model RS1□			30*	30*	30*	10*	15*
*Rated output	P_R	kW	5.5	7.5	11	3.5	5.0
*Rated speed	N_R	min^{-1}	1500	1500	1500	2000	2000
*Maximum speed	N_{max}	min^{-1}	3000	3000	2500	4000	4000
*Rated torque	T_R	$\text{N}\cdot\text{m}$	35.0	48.0	70.0	17.0	24
*Continuous stall torque	T_S	$\text{N}\cdot\text{m}$	37.5	54.9	80.0	22.0	32
*Peak armature current at stall	T_P	$\text{N}\cdot\text{m}$	107.0	140.0	170.0	50.0	75
*Rated armature current	I_R	Arms	46.2	51.2	61.9	18.0	22.0
*Peak armature current at stall	I_S	Arms	48.0	56.8	66.0	22.0	34.0
*Peak armature current	I_P	Arms	155.0	155.0	155.0	55.0	83.0
Torque constant	K_T	$\text{N}\cdot\text{m}/\text{Arms}$	0.84	1.04	1.25	1.04	1.0
Voltage constant for each phase	$K_{E\Phi}$	$\text{mV}/\text{min}^{-1}$	29.3	36.6	43.8	36.2	34.9
Phase resistance	R_Φ	Ω	0.03	0.03	0.035	0.094	0.047
*Rated power rate	Q_R	kW/s	180	235	445	69	105
Inertia (including Wiring INC)	J_M	$\text{kg}\cdot\text{m}^2$ ($\text{GD}^2/4$) $\times 10^{-4}$	68	98	110	42	55
Aluminium plate		mm	t20×540	t20×540	t20×610	t20×470	t2×470

AC100V Input specification

Servo Motor model R2EA			04003F	04005F	04008F	06010F	06020F
Servo Amplifier model RS1□			01*	01*	01*	01*	03*
*Rated output	P_R	kW	0.03	0.05	0.08	0.1	0.2
*Rated speed	N_R	min^{-1}	3000	3000	3000	3000	3000
*Maximum speed	N_{max}	min^{-1}	6000	6000	6000	6000	6000
*Rated torque	T_R	$\text{N}\cdot\text{m}$	0.098	0.159	0.255	0.318	0.637
*Continuous stall torque	T_S	$\text{N}\cdot\text{m}$	0.108	0.167	0.255	0.318	0.686
*Peak armature current at stall	T_P	$\text{N}\cdot\text{m}$	0.37	0.59	0.86	1.0	2.2
*Rated armature current	I_R	Arms	0.94	1.2	1.3	1.7	3.1
*Peak armature current at stall	I_S	Arms	1.0	1.3	1.3	1.7	3.2
*Peak armature current	I_P	Arms	3.7	4.9	4.5	5.6	11.9
Torque constant	K_T	$\text{N}\cdot\text{m}/\text{Arms}$	0.116	0.142	0.22	0.206	0.224
Voltage constant for each phase	$K_{E\Phi}$	$\text{mV}/\text{min}^{-1}$	4.04	4.97	7.7	7.2	7.82
Phase resistance	R_Φ	Ω	4.0	3.0	2.9	1.5	0.6
*Rated power rate	Q_R	kW/s	3.9	6.7	10	8.6	19
Inertia (including Wiring INC)	J_M	$\text{kg}\cdot\text{m}^2$ ($\text{GD}^2/4$) $\times 10^{-4}$	0.028	0.0409	0.066	0.120	0.222
Aluminium plate		mm	t6×250	t6×250	t6×250	t6×250	t6×250

Materials

Servo motor data sheet [velocity-torque characteristics]

Q1AA Motor velocity-torque characteristics indicate the values in combination with an amplifier 3-phase when amplifier power supply is AC200V. Instant domain decreases when amplifier power supply is below 200V.

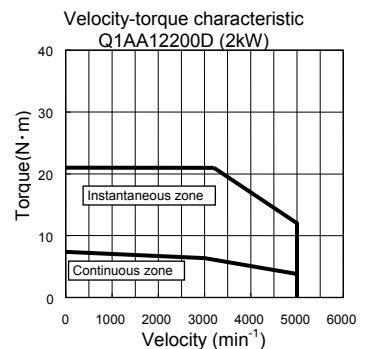
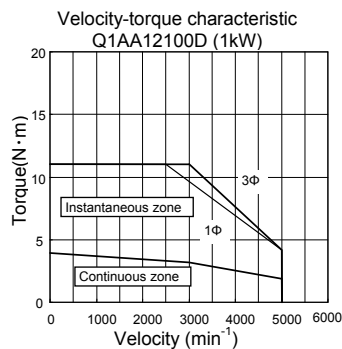
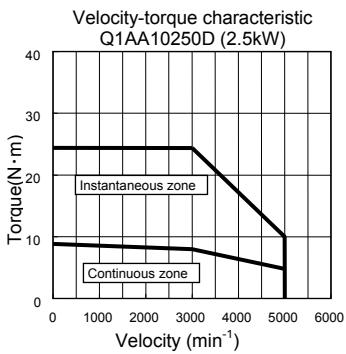
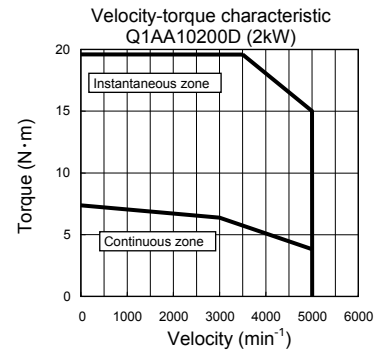
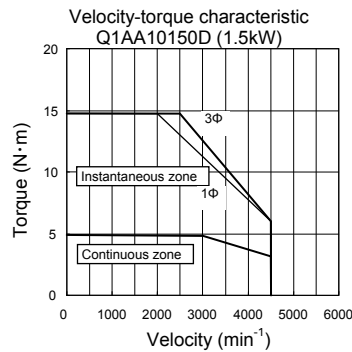
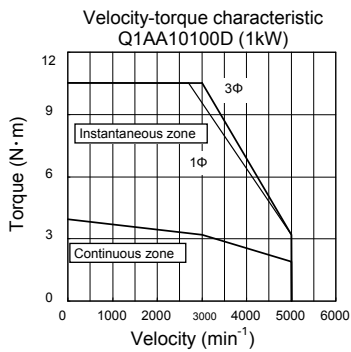
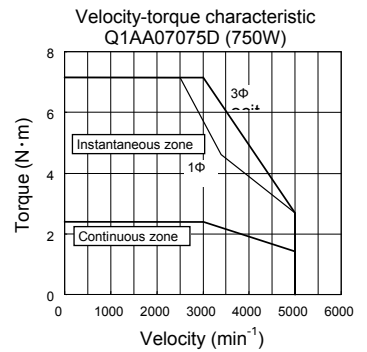
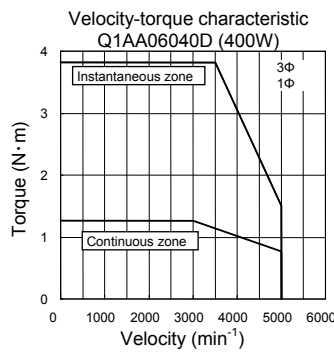
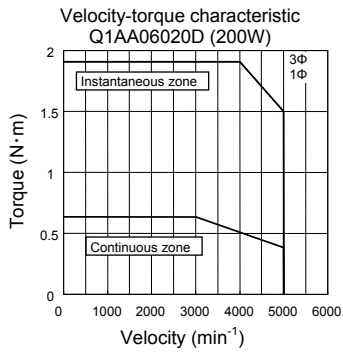
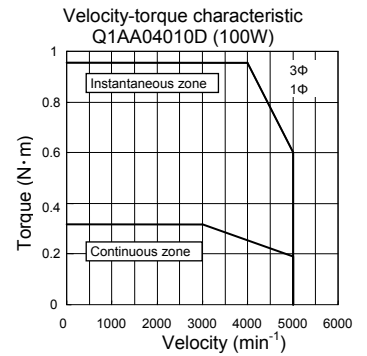
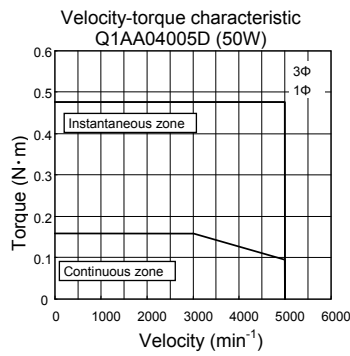
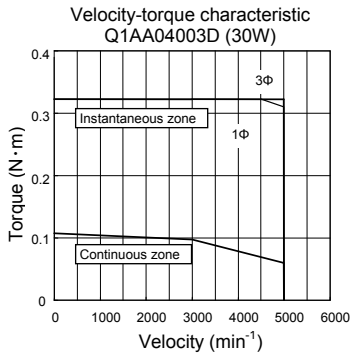

Materials

Servo motor data sheet [velocity-torque characteristics]

Q1AA Motor velocity-torque characteristics indicate the values in combination with an amplifier 3-phase when amplifier power supply is AC200V. Instant domain decreases when amplifier power supply is below 200V.

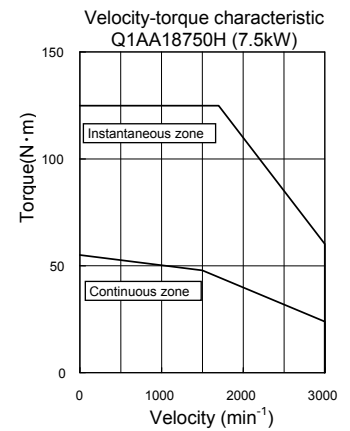
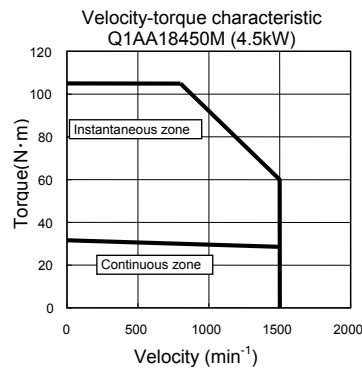
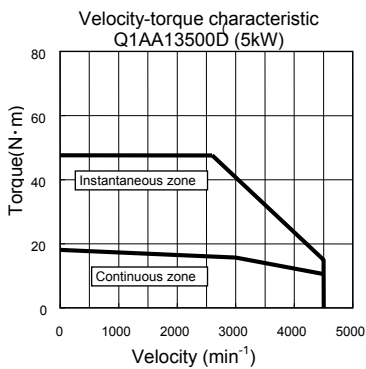
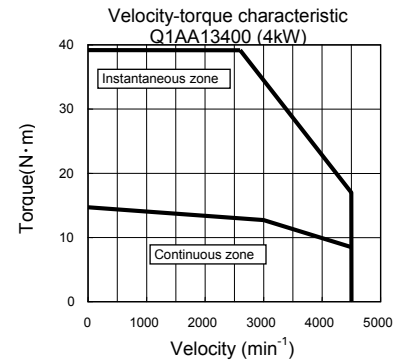
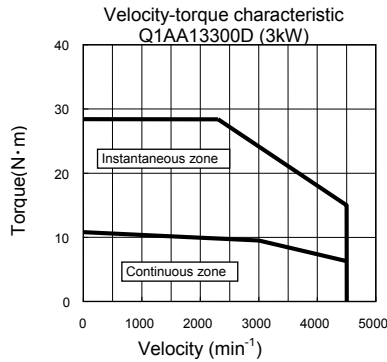
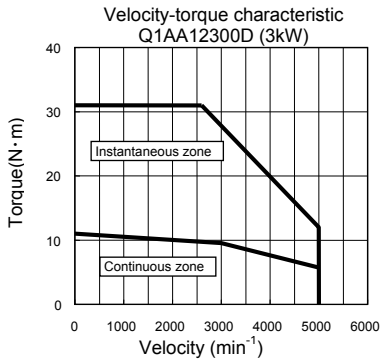

Q1EA Motor velocity-torque characteristics indicate the values in combination with operation amplifier for single-phase when amplifier power supply is AC100V. Instant domain decreases when amplifier power supply is below 100V.

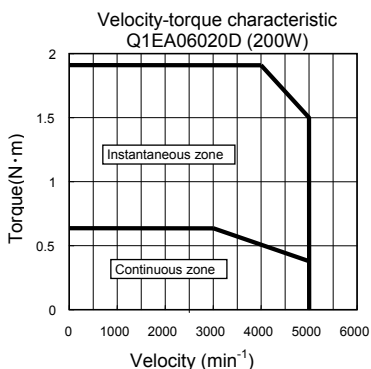
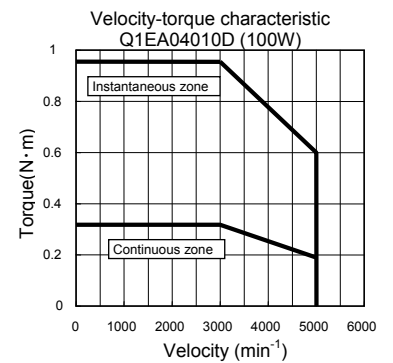
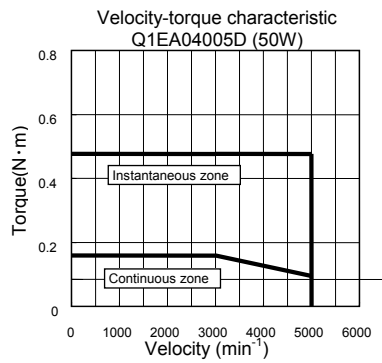
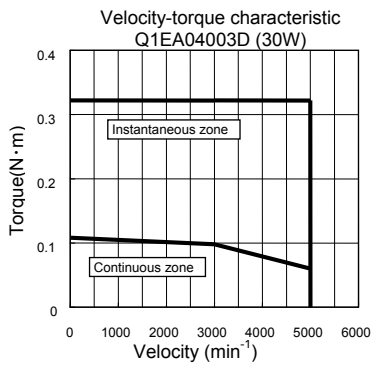

Materials

Servo motor data sheet [velocity-torque characteristics]

Q2AA Motor velocity-torque characteristics indicate the values in combination with operation amplifier for 3-phase when amplifier power supply is AC 200V. Instant domain decreases when amplifier power supply is below 200V.

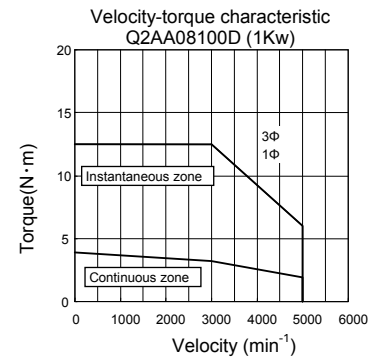
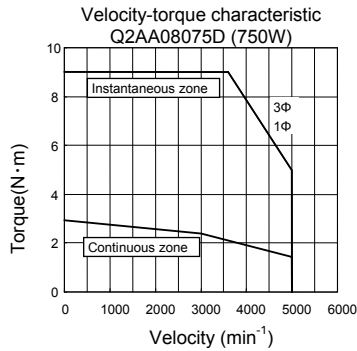
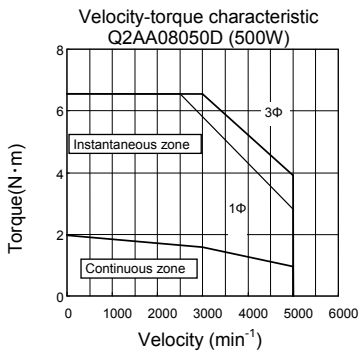
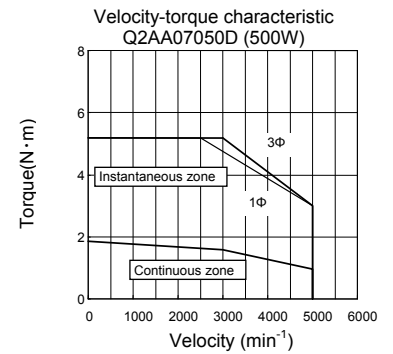
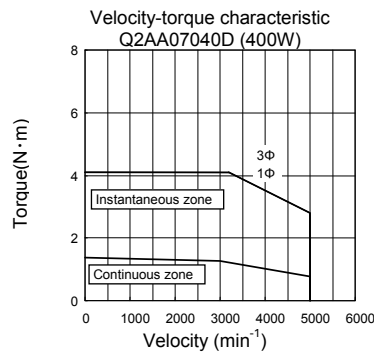
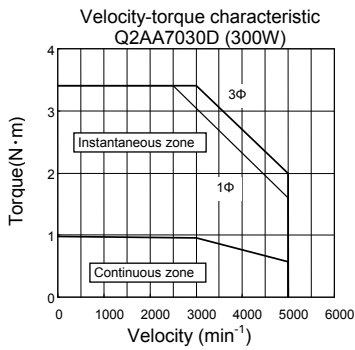
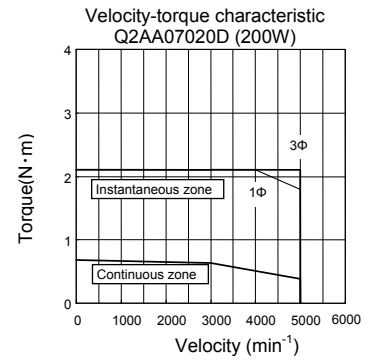
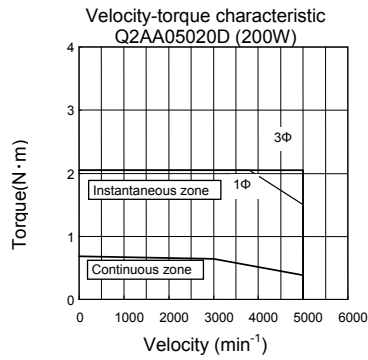
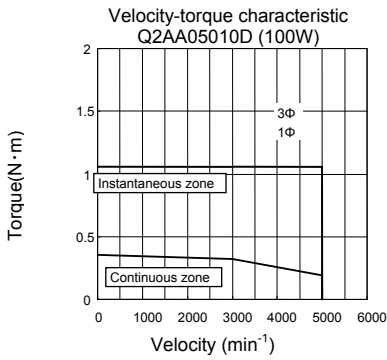
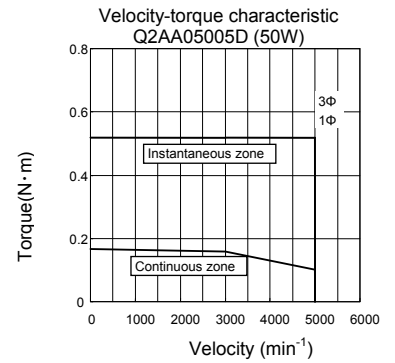
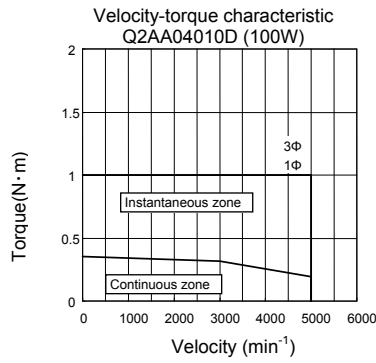
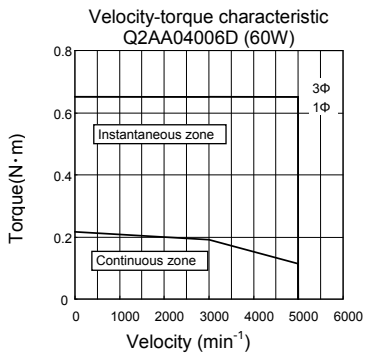

Q2AA Motor velocity-torque characteristics indicate the values in combination with operation amplifier for 3-phase when amplifier power supply is AC 200V. Instant domain decreases when amplifier power supply is below 200V.

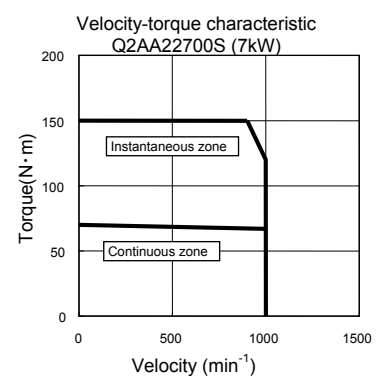
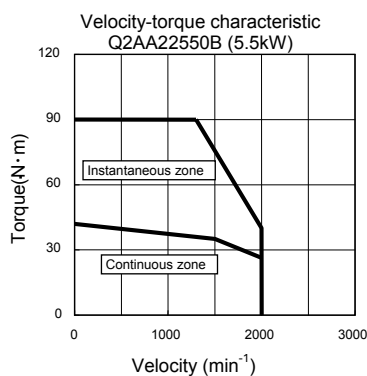
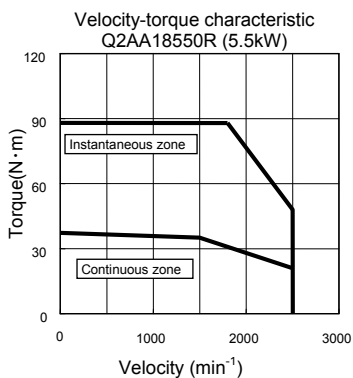
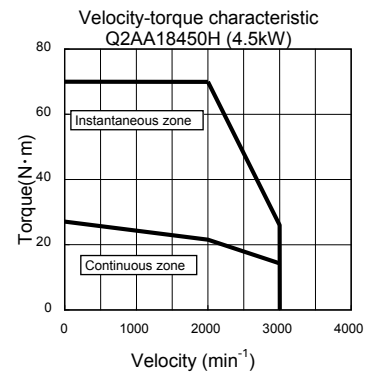
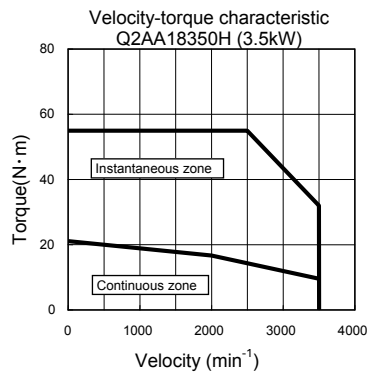
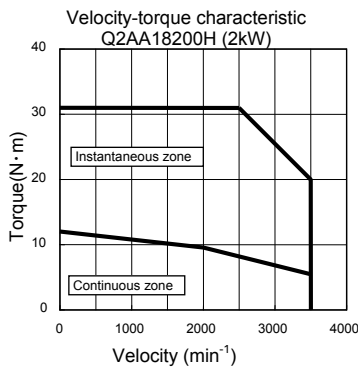
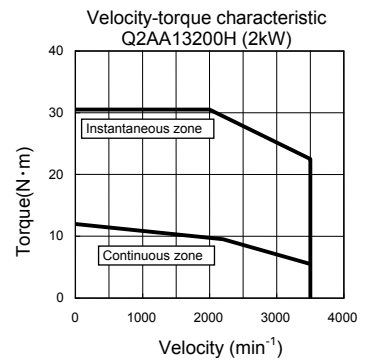
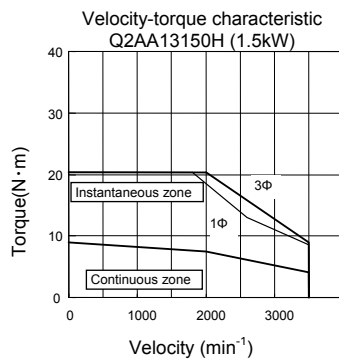
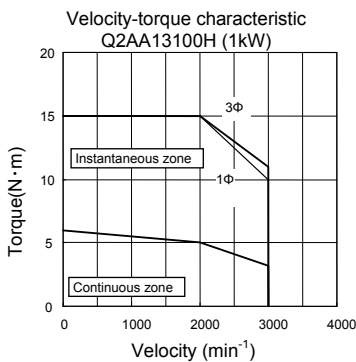
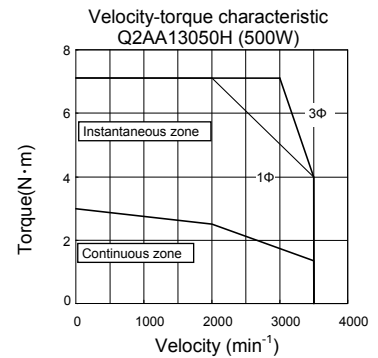
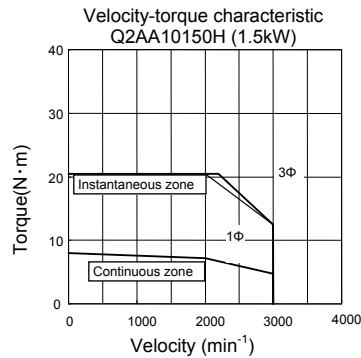
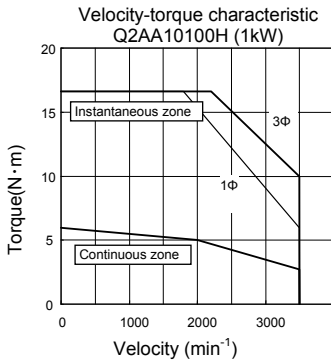

Materials

Servo motor data sheet [velocity-torque characteristics]

Q2AA Motor velocity-torque characteristics indicate the values in combination with operation amplifier for 3-phase when amplifier power supply is AC 200V. Instant domain decreases when amplifier power supply is below 200V.

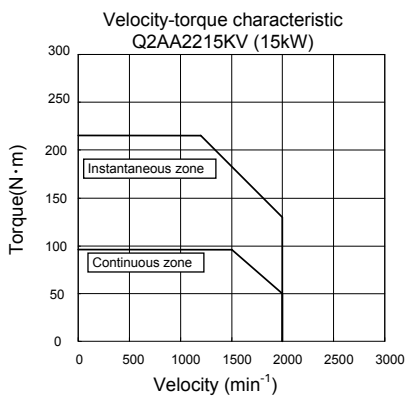
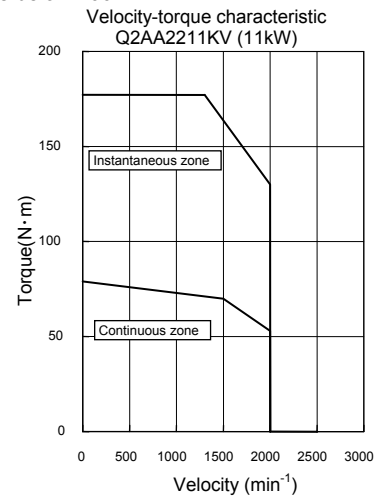
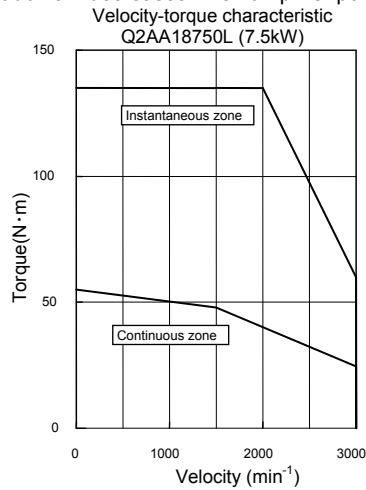
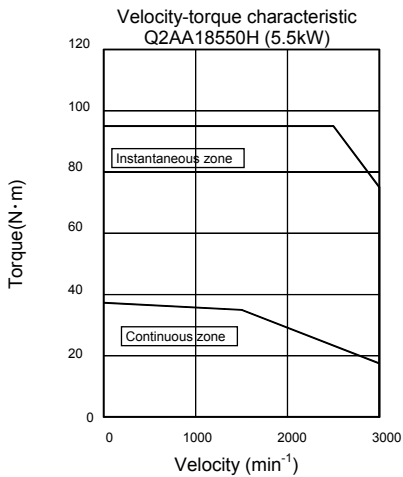

Q2EA Motor velocity-torque characteristics indicate the values in combination with operation amplifier for single-phase when amplifier power supply is AC100V. Instant domain decreases when amplifier power supply is below 100V.

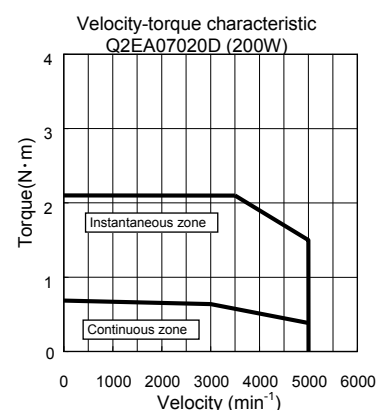
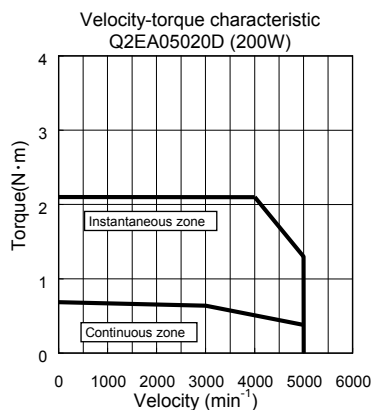
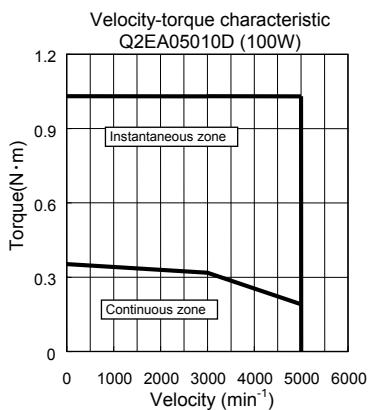
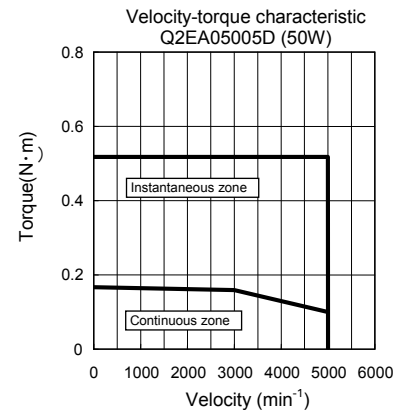
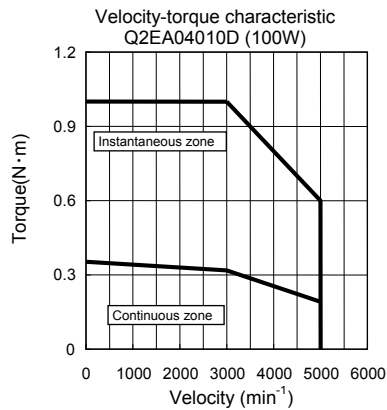
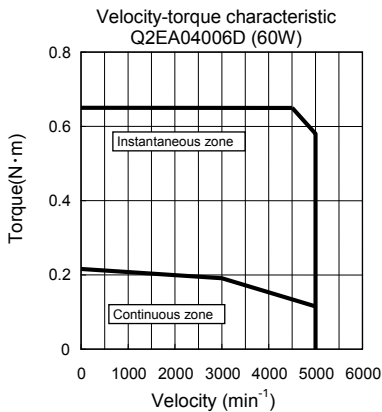

Materials

Servo motor data sheet [velocity-torque characteristics]

R2AA Motor velocity-torque characteristics indicate the values in combination with operation amplifier for 3-phase and single-phase when amplifier power supply is AC 200V. Instant domain decreases when amplifier power supply is below 200V.

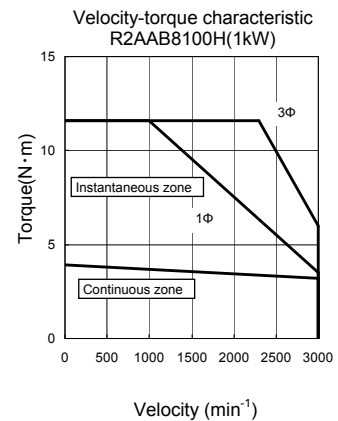
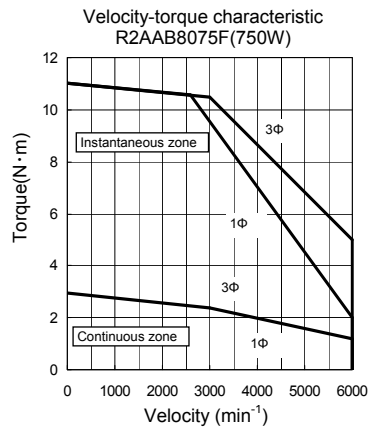
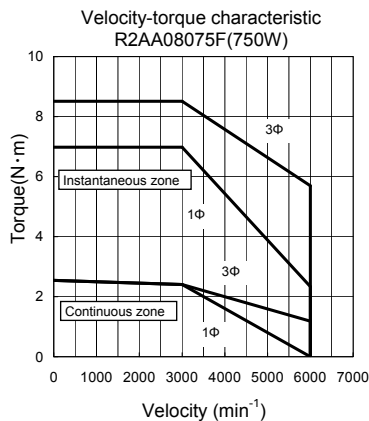
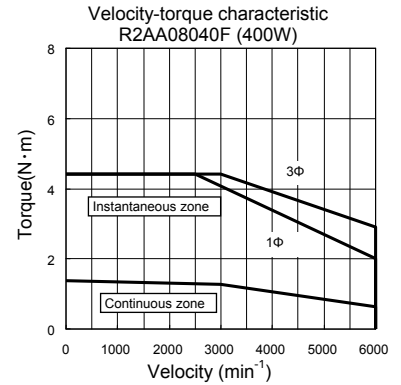
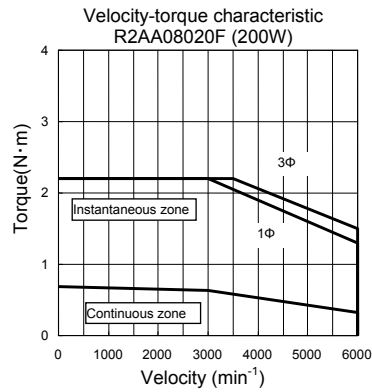
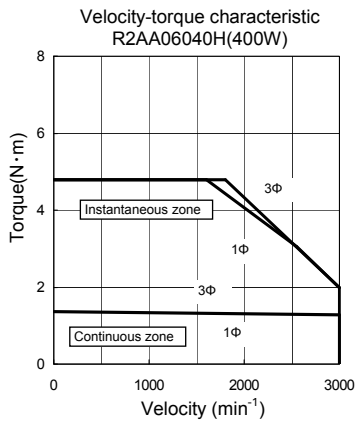
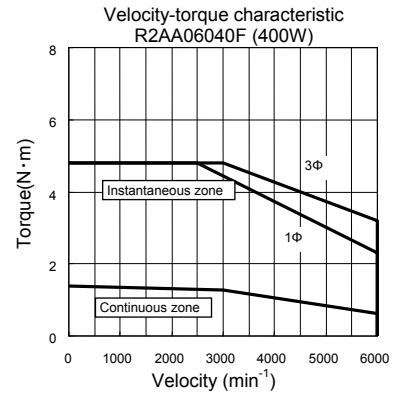
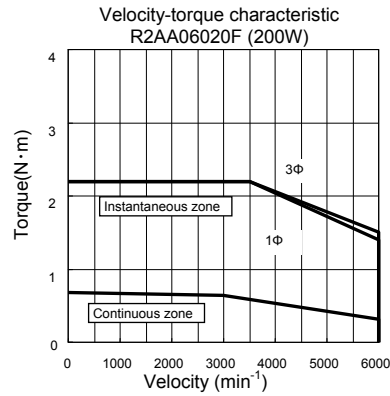
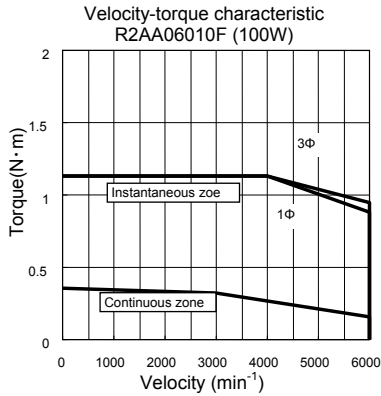
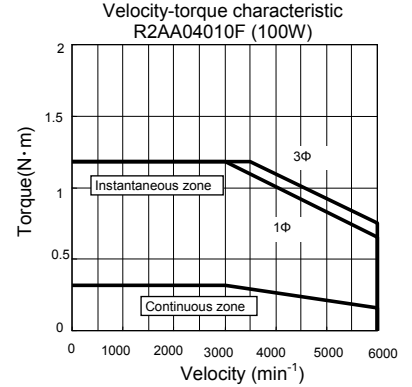
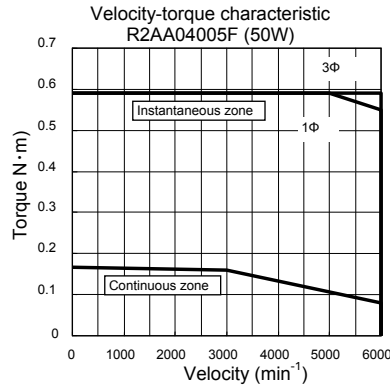
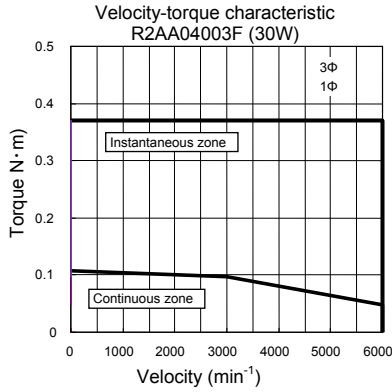

R2AA Motor velocity-torque characteristics indicate the values in combination with operation amplifier for 3-phase and single-phase when amplifier power supply is AC 200V. Instant domain decreases when amplifier power supply is below 200V.

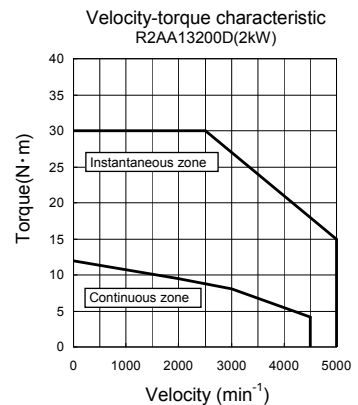
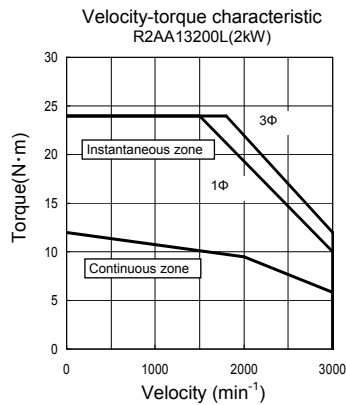
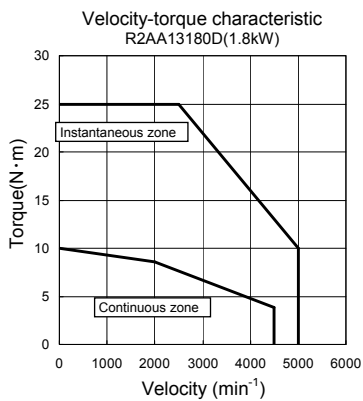
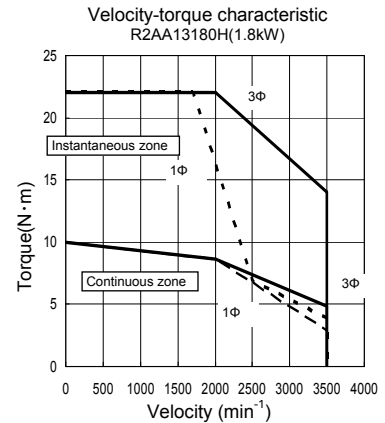
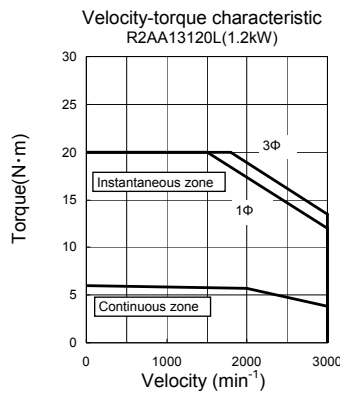
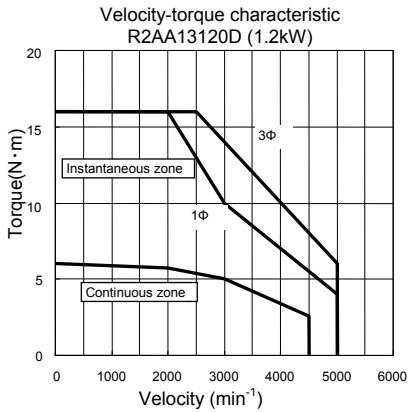
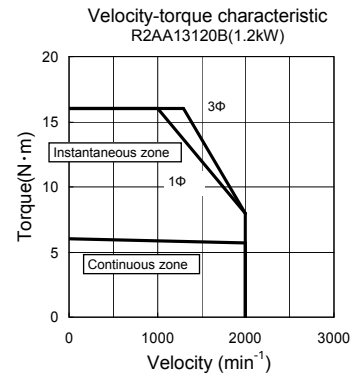
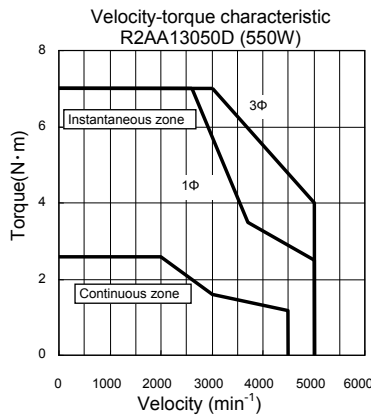
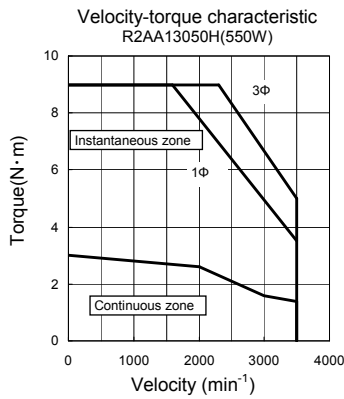
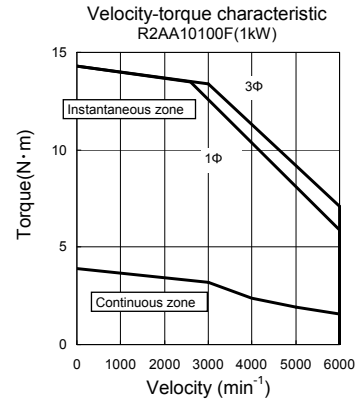
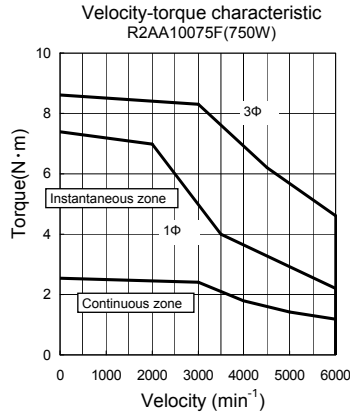
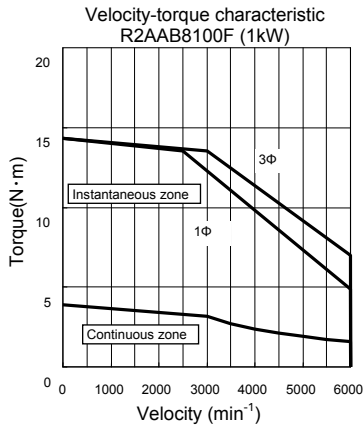

Materials Servo motor data sheet [velocity-torque characteristics]

R2AA Motor velocity-torque characteristics indicate the values in combination with operation amplifier for 3-phase and single-phase when amplifier power supply is AC 200V. Instant domain decreases when amplifier power supply is below 200V.

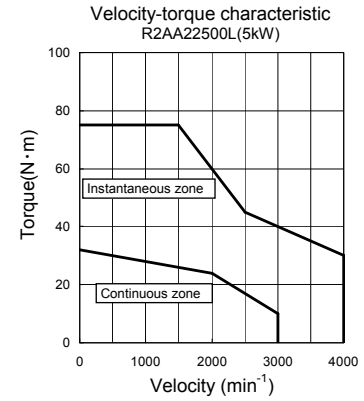
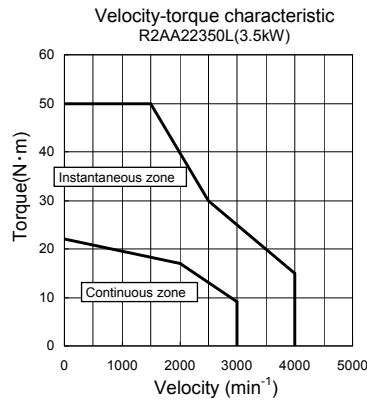
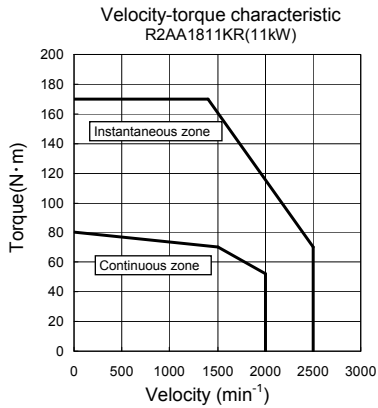
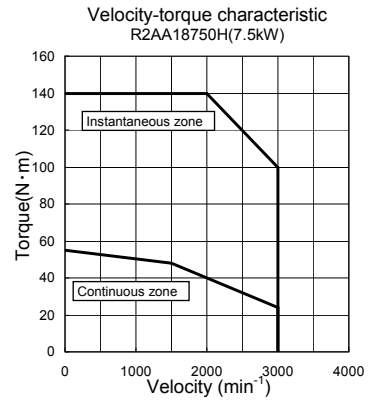
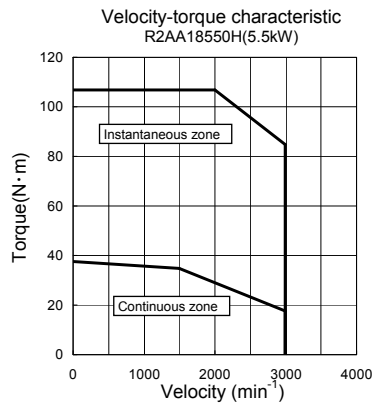
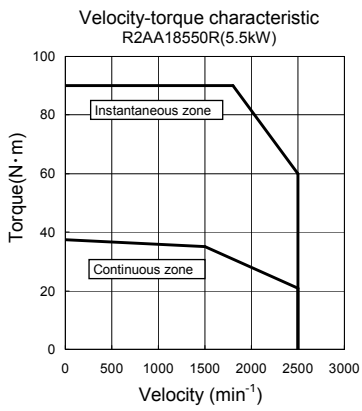
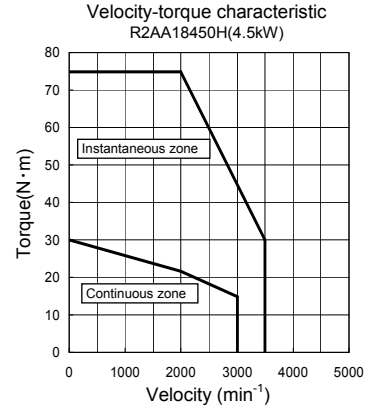
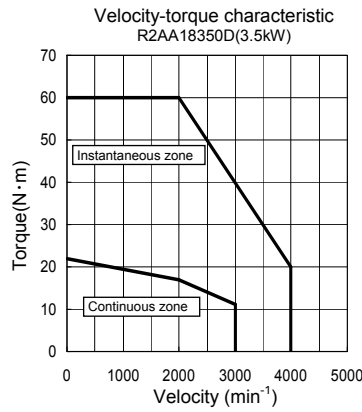
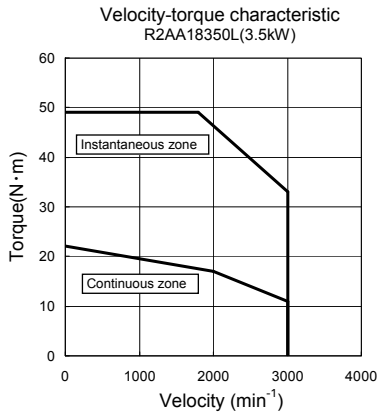

Materials Servo motor data sheet [velocity-torque characteristics]

R2EA Motor velocity-torque characteristics indicate the values in combination with operation amplifier for single-phase when amplifier power supply is AC100V. Instandomain decreases when amplifier power supply is below 100V.

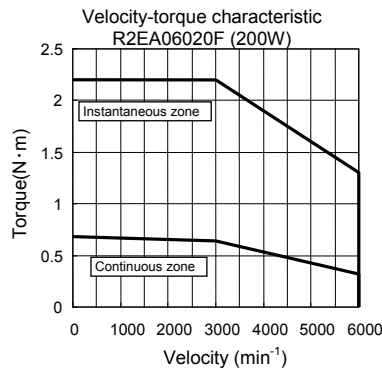
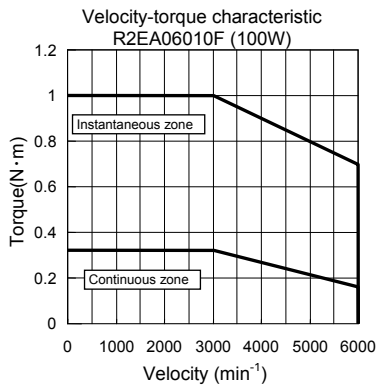
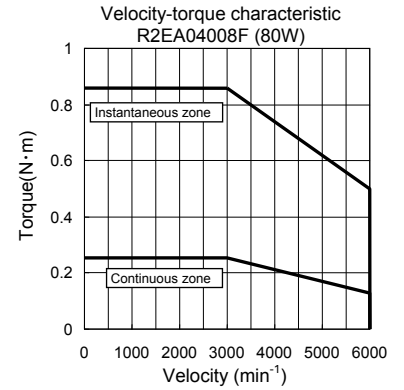
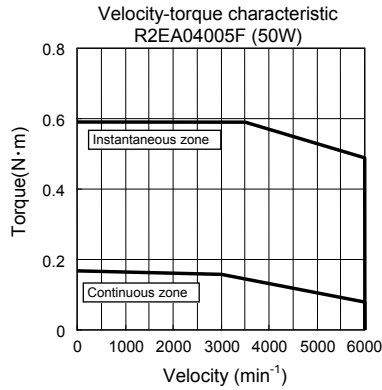
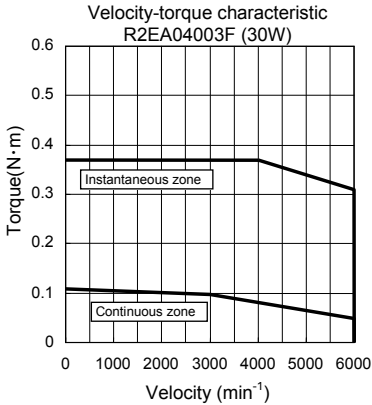

- Degree of decrease rating: R2 Motor fixed oil seal and brake
About oil seal and brake fixed, considering of a rise in heat, continuous zone should apply the following degree of decrease rating.

Oilseal Brake	non-fixed oil seal	fixed oil seal
with no brake	No decrease rating	decrease rating 2
with brake	decrease rating 1	decrease rating 2

Decrease rating 1	Servo Motor Model	R2AA 04010F	R2AA 06040F
	degree of decrease rating %	90	

Decrease rating 2	Servo Motor Model	R2AA 04005F	R2AA 04010F	R2AA 06040F	R2AA 08075F	R2EA 04005F
	degree of decrease rating %	90	85	80	90	90

Q1AA Motor overload characteristics indicates.

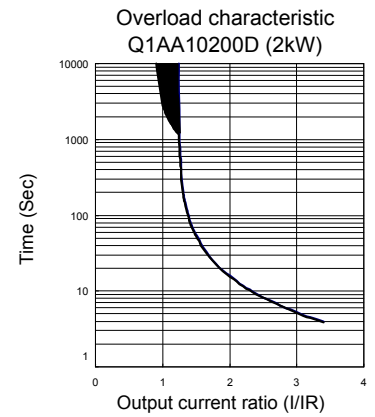
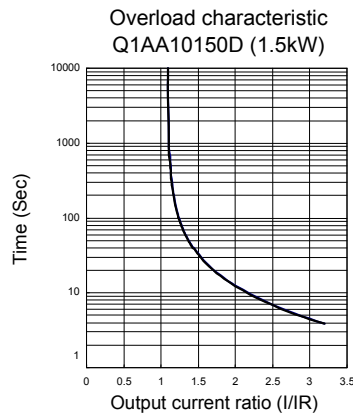
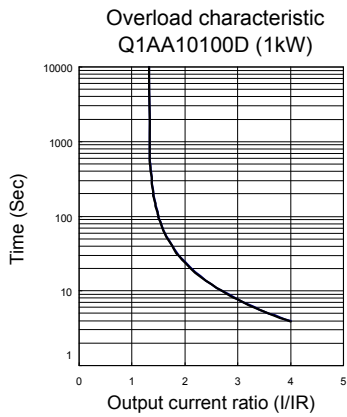
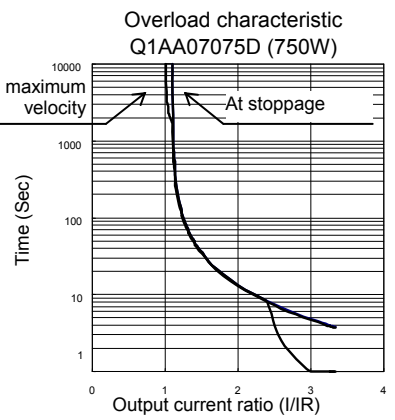
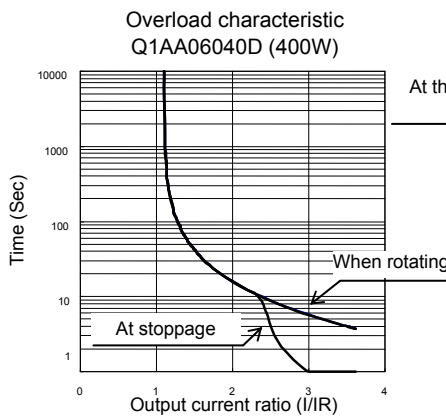
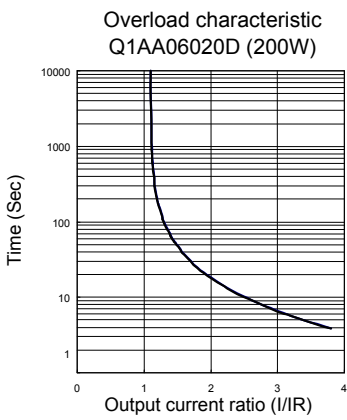
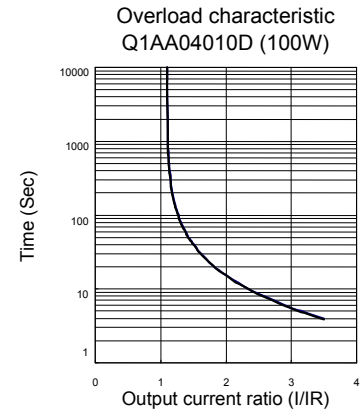
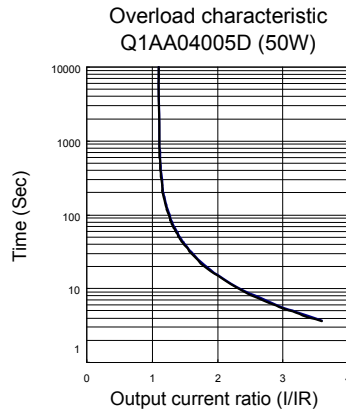
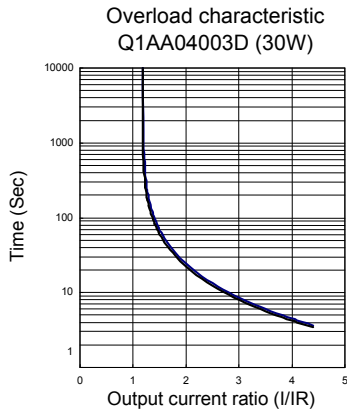

Q1AA Motor overload characteristics indicates.

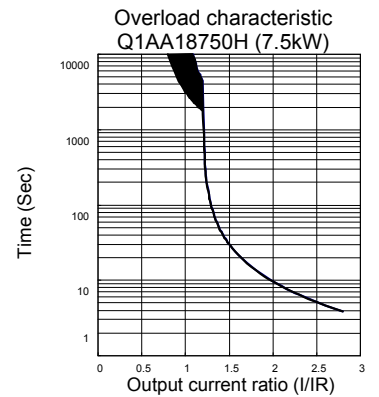
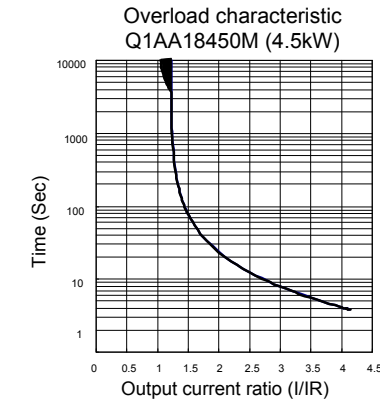
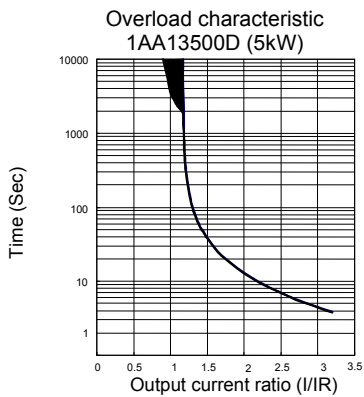
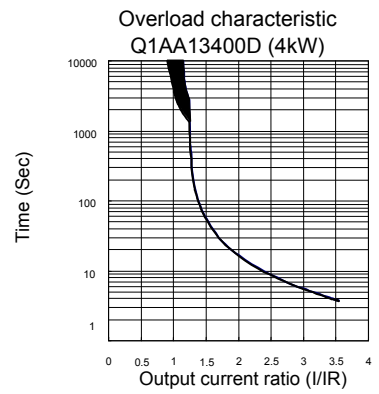
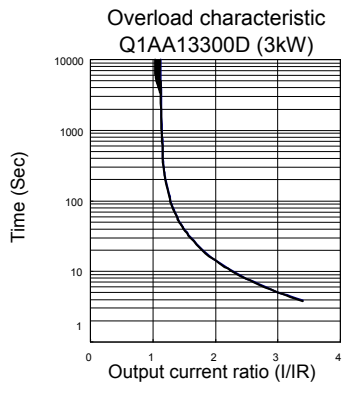
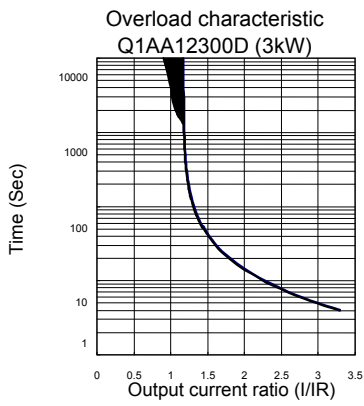
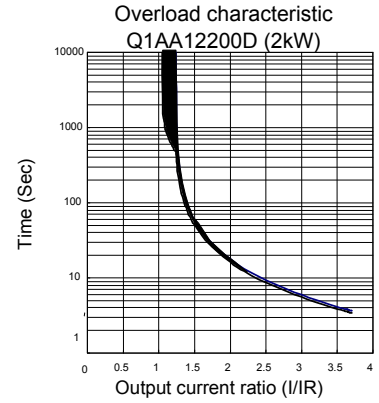
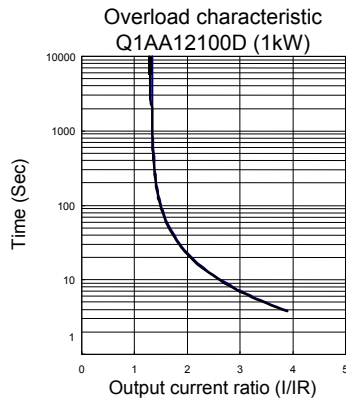
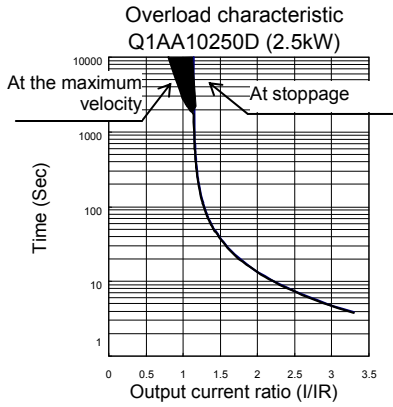

Q1EA Motor overload characteristics indicates.

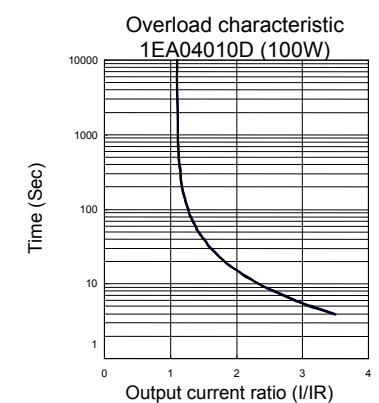
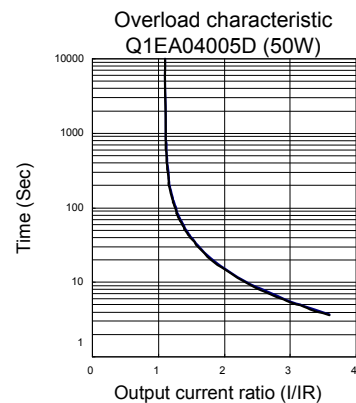
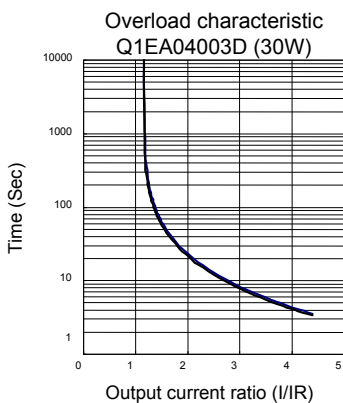

Q1EA Motor overload characteristics indicates.

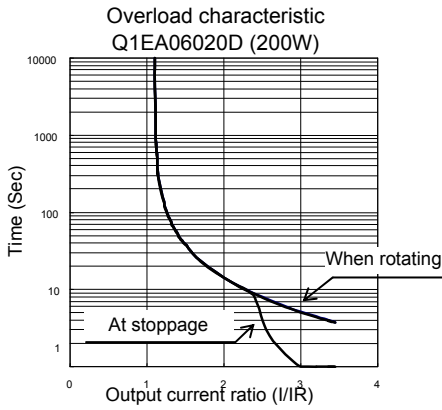

Q2AA Motor overload characteristics indicates.

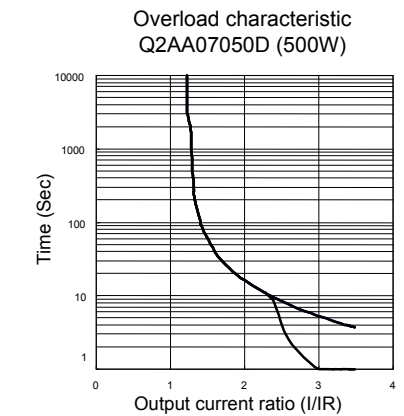
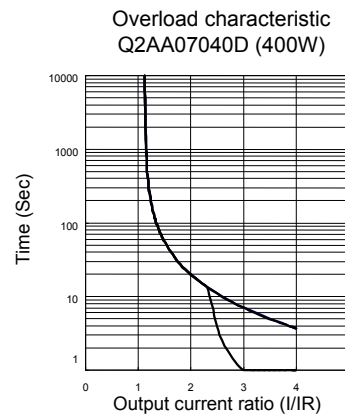
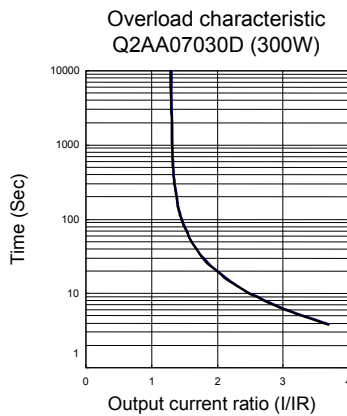
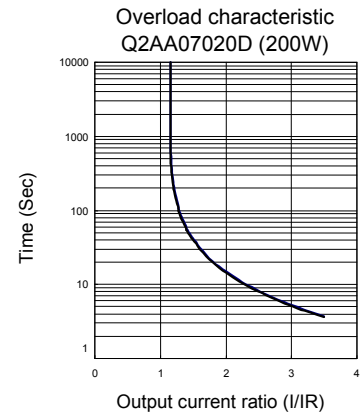
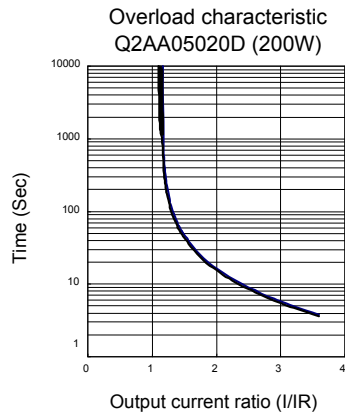
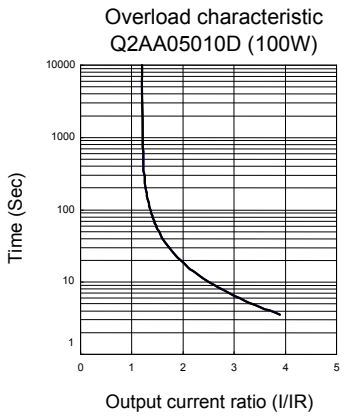
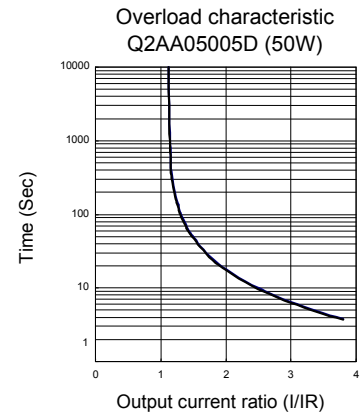
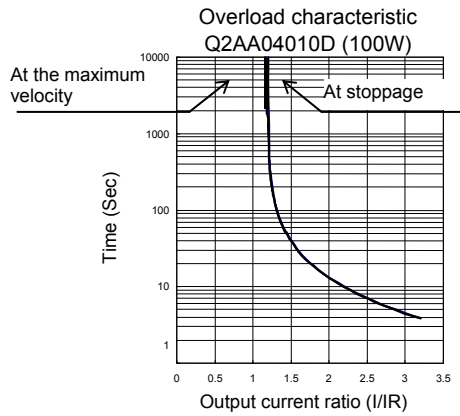
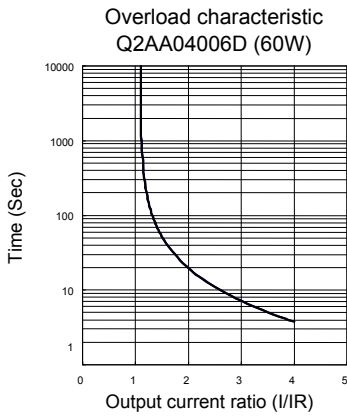

Q2AA Motor overload characteristics indicates.

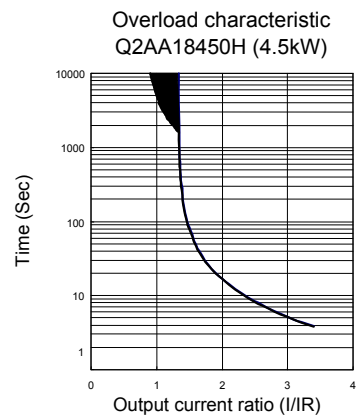
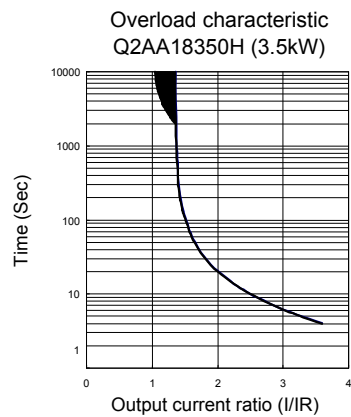
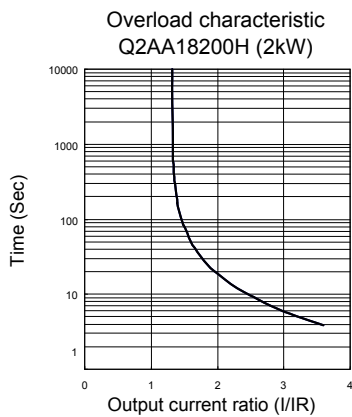
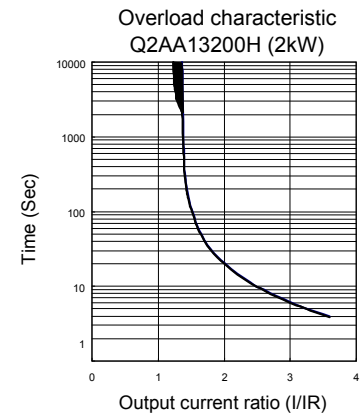
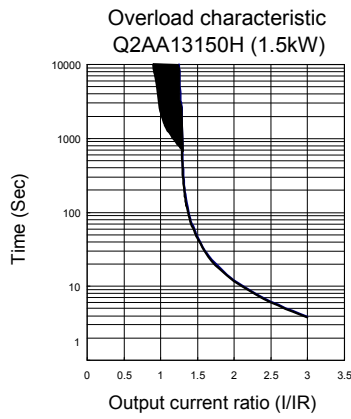
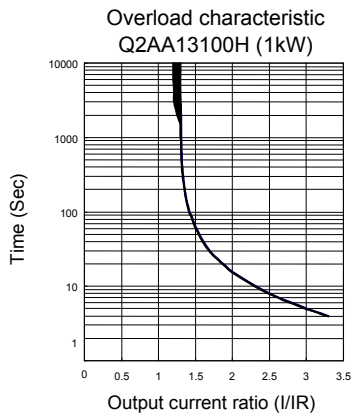
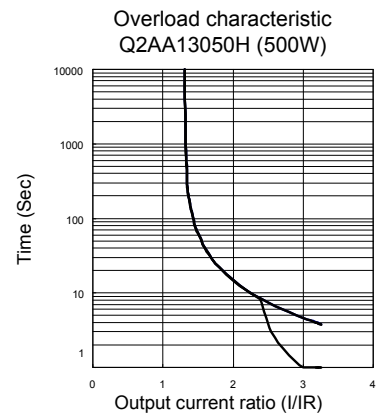
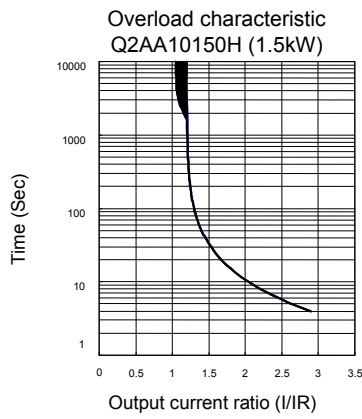
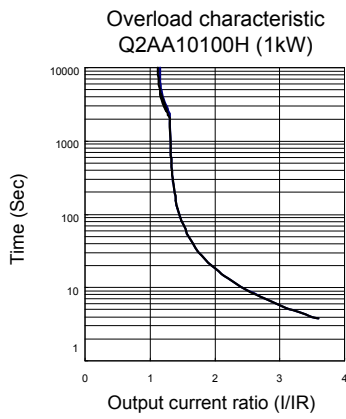
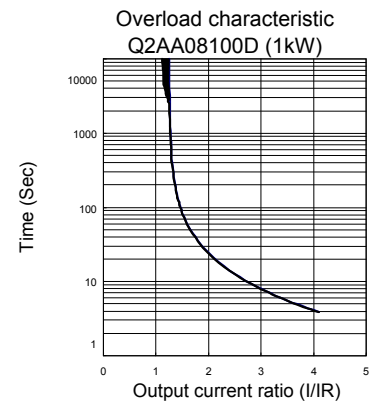
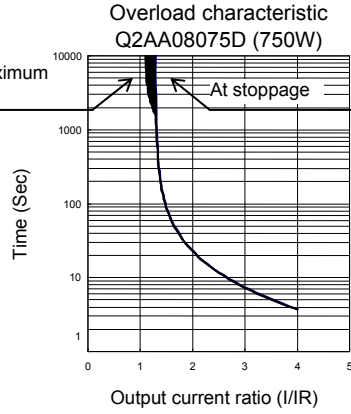
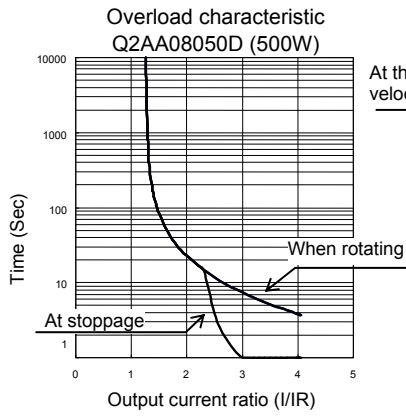

Materials

Servo motor data sheet [Overload characteristics]

Q2AA Motor over load characteristics indicates.

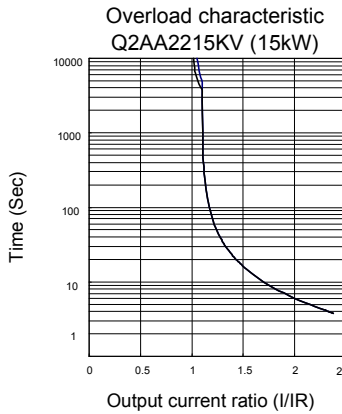
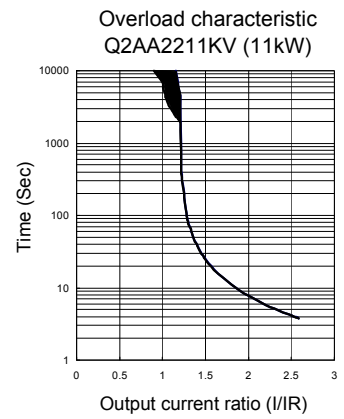
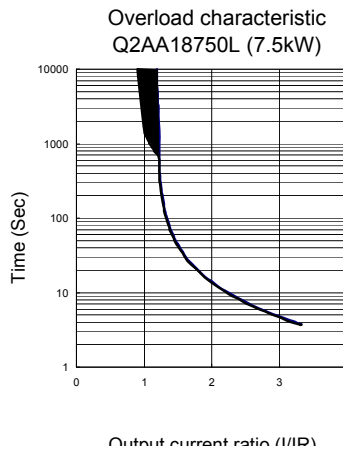
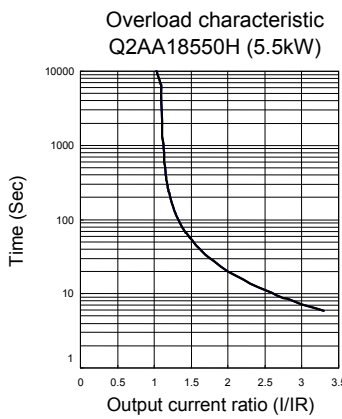
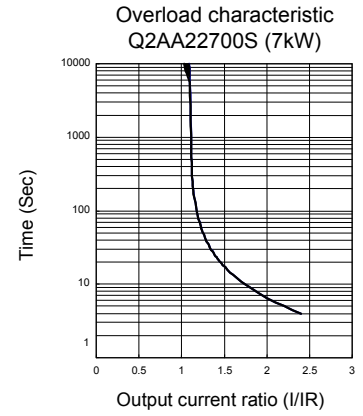
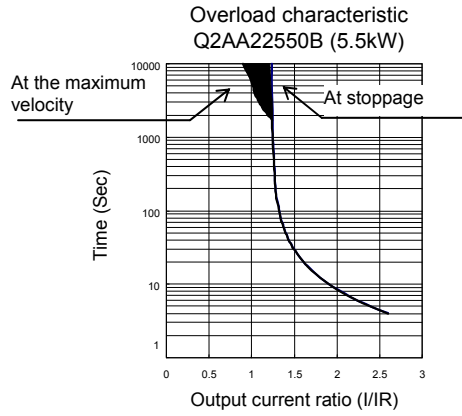
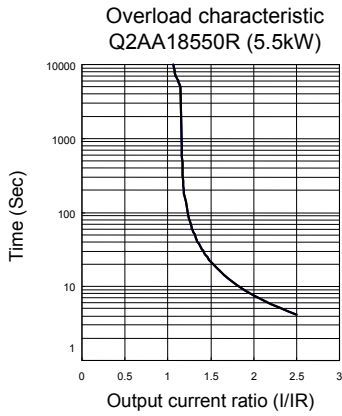

Q2EA Motor over load characteristics indicates.

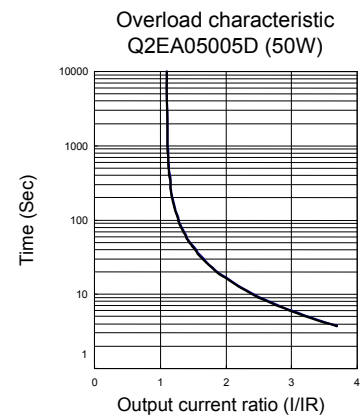
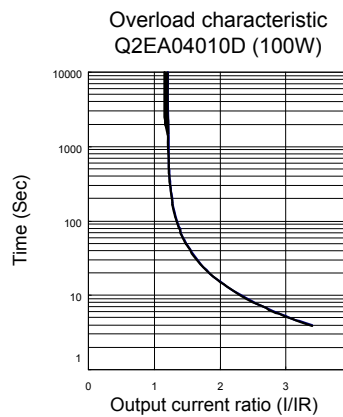
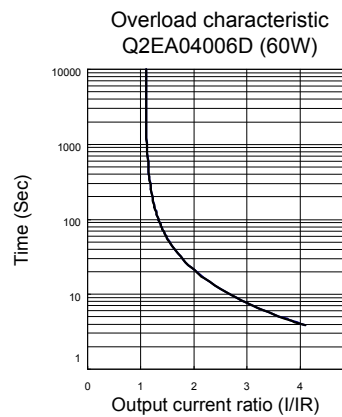

Materials

Servo motor data sheet [Overload characteristics]

Q2EA Motor over load characteristics indicates.

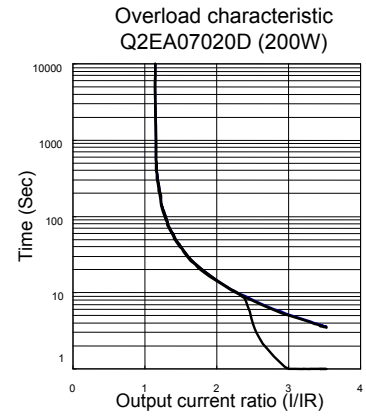
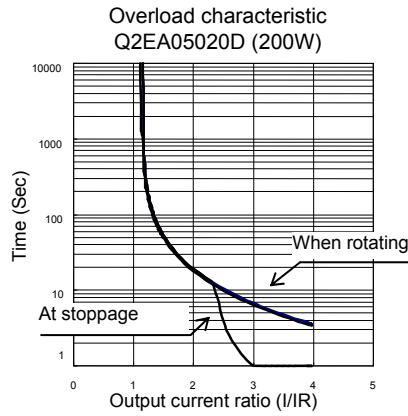
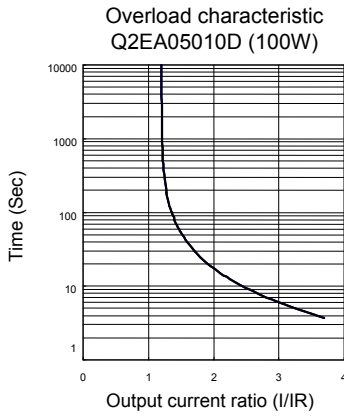

R2AA Motor over load characteristics indicates.

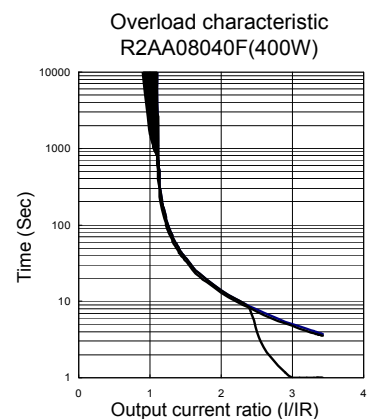
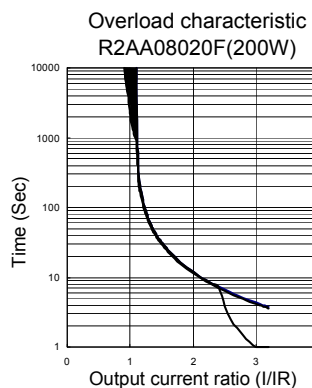
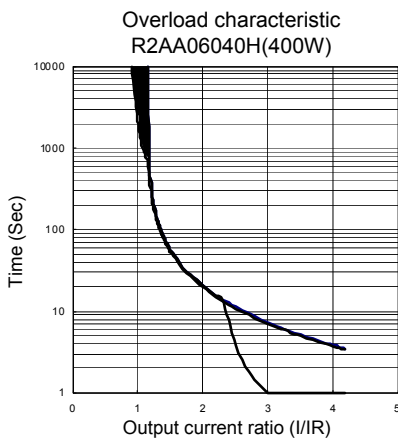
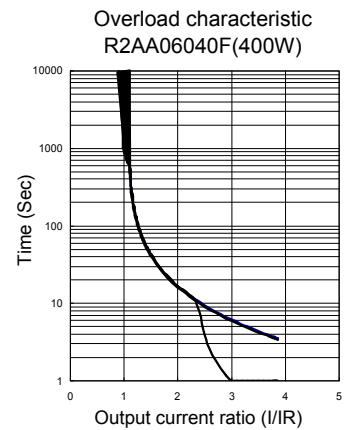
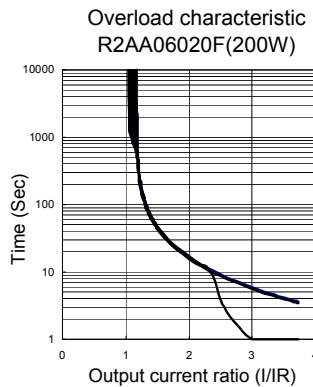
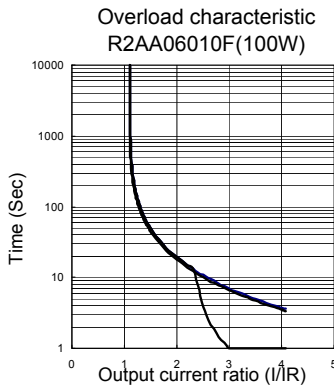
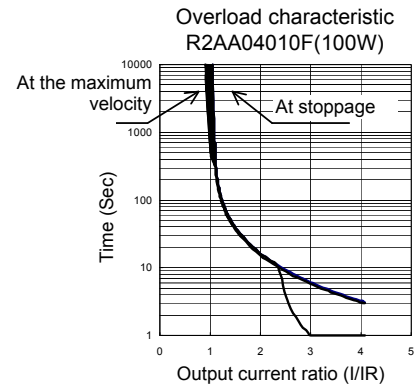
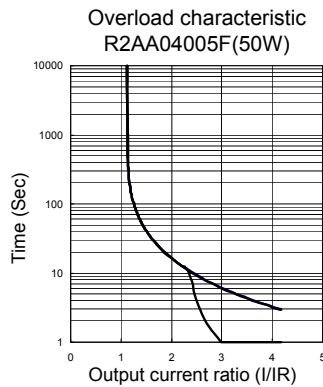
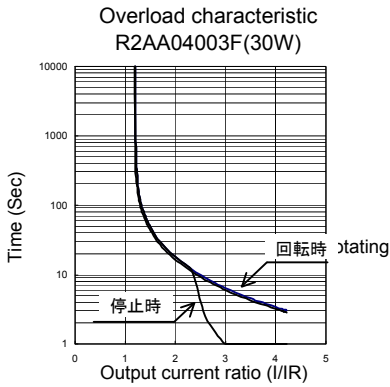

R2AA Motor over load characteristics indicates.

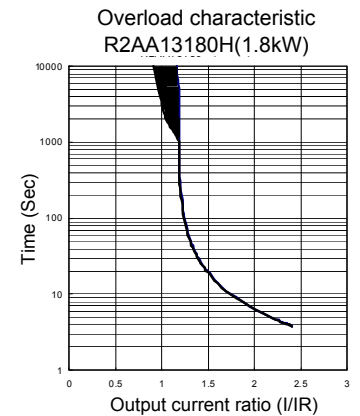
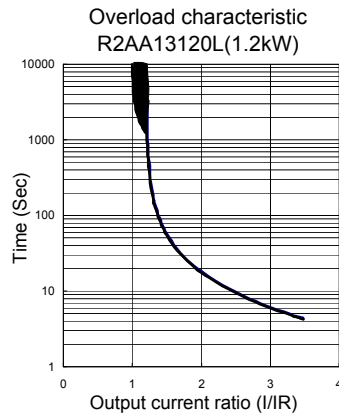
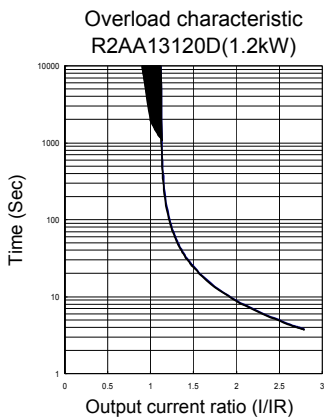
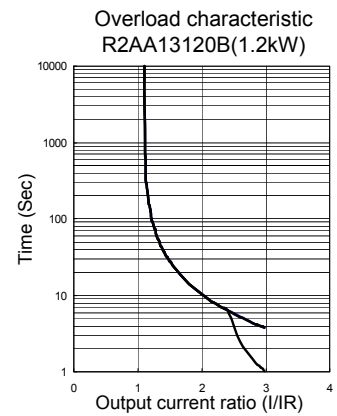
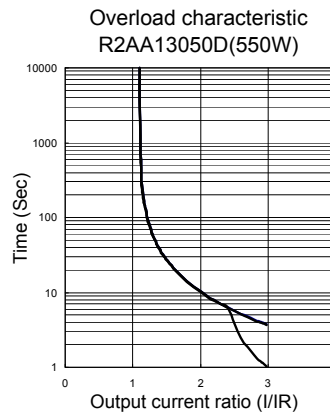
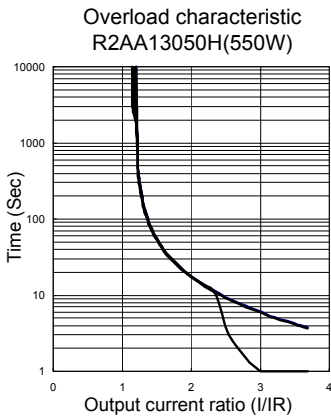
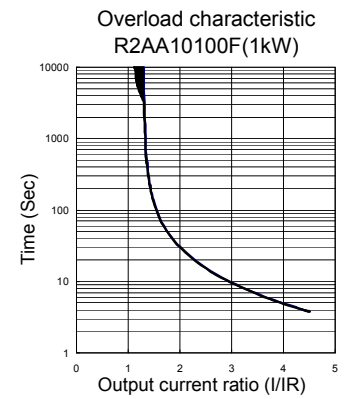
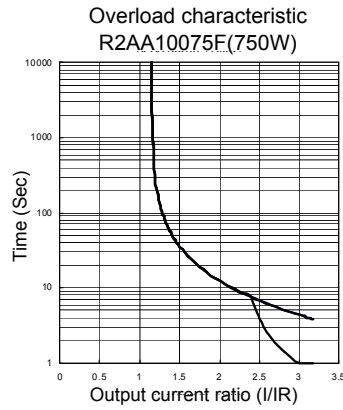
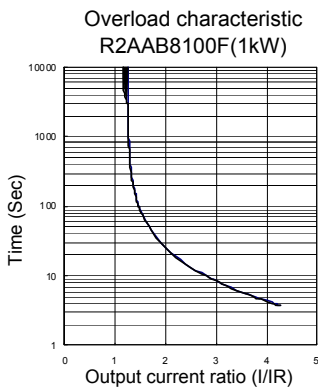
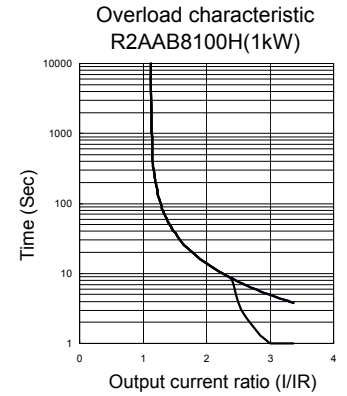
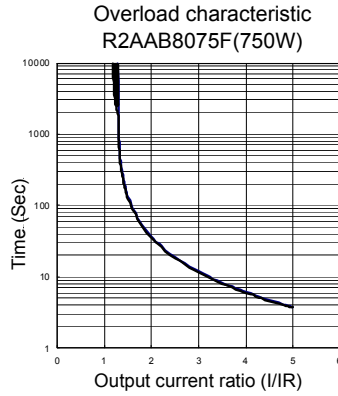
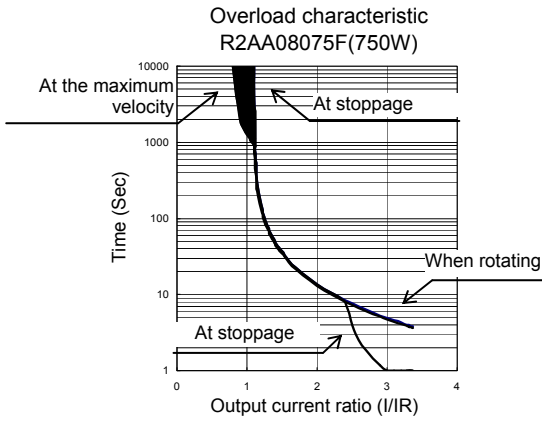

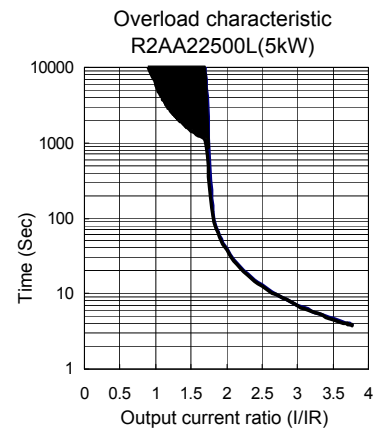
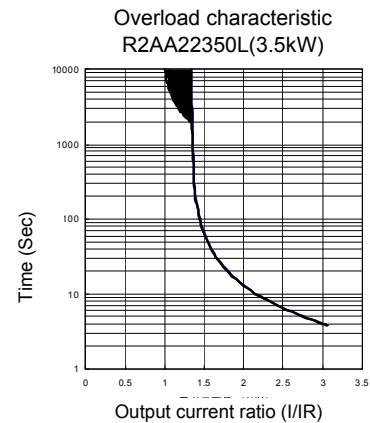
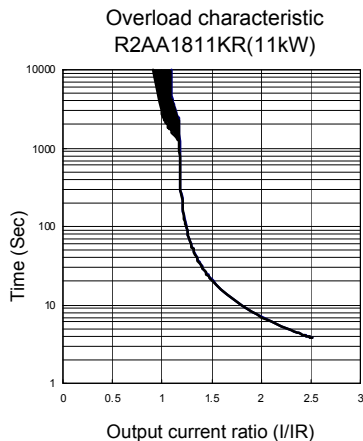
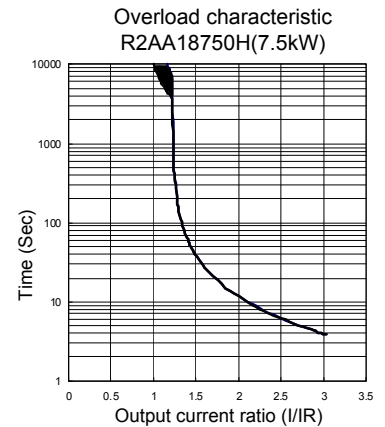
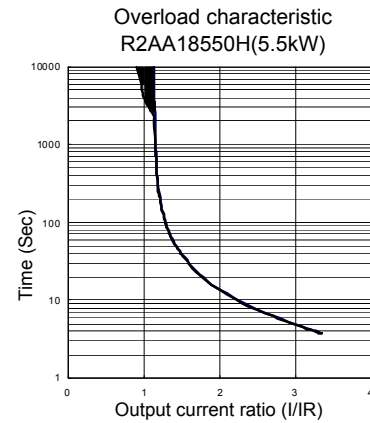
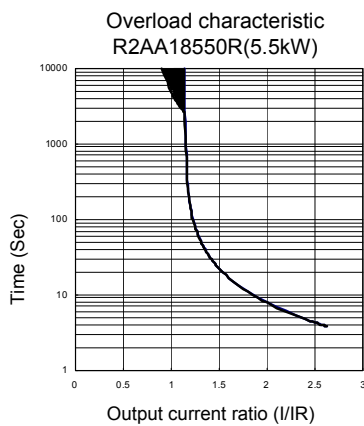
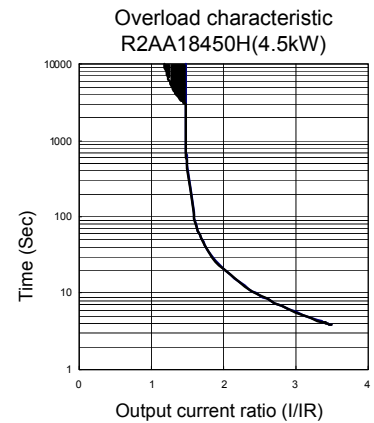
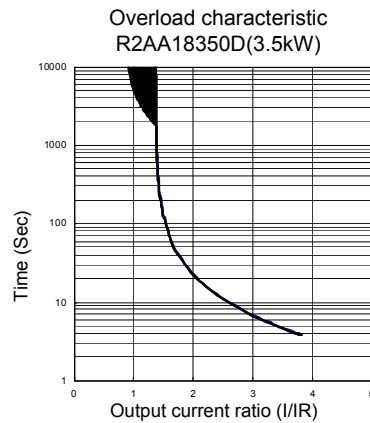
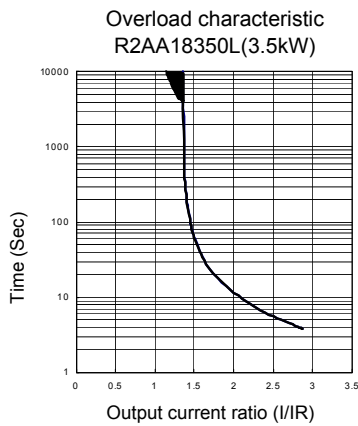
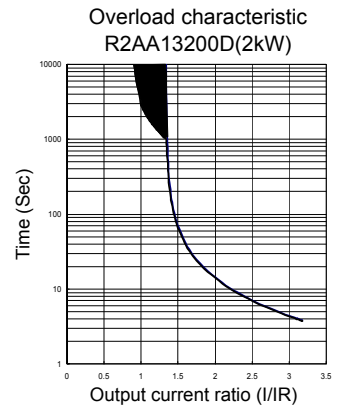
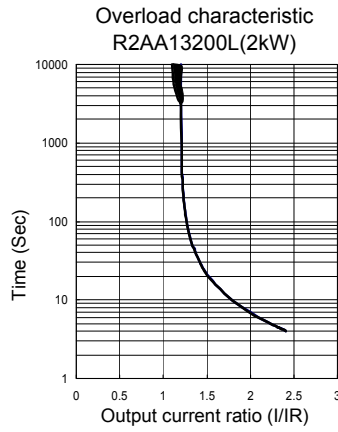
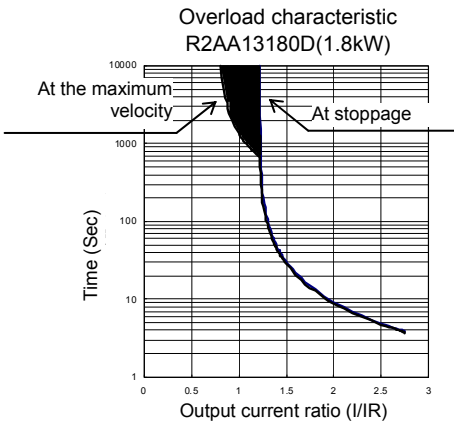

R2EA Motor over load characteristics indicates.

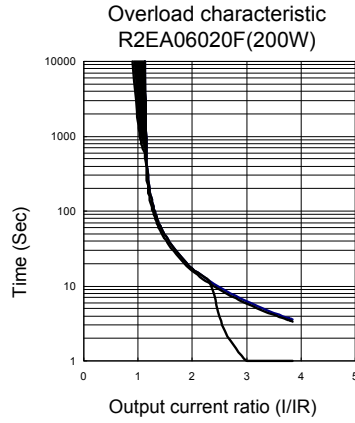
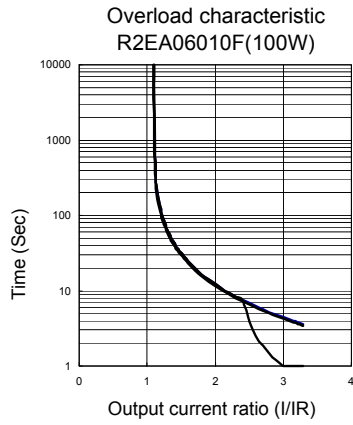
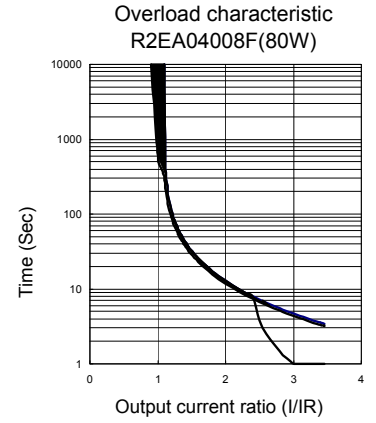
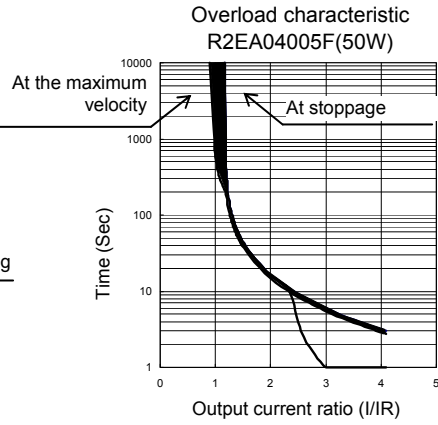
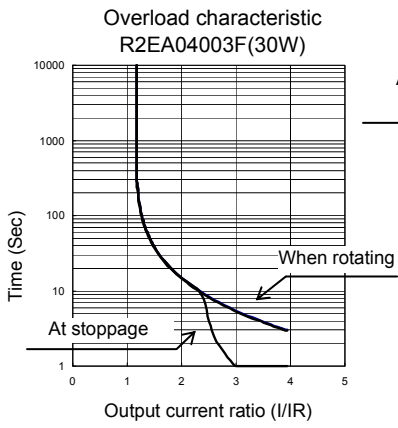

Input-output connector

Connector table for AC 200V input type

Application	Model number	Contents	Manufacturer	Manufacturer's model number
Single connector	AL-00385594	CN1 Plug and housing	Sumitomo 3M Ltd.	10150-3000PE
				10350-52A0-008
	AL-00385596	CN2 Plug and housing	Sumitomo 3M Ltd.	10120-3000PE
				10320-52A0-008
	AL-00329461-01	CNA plug	Phoenix Contact Co. Ltd.	MSTB2.5/5-STF-5.08
AL-Y0000988-01	CNB plug	Phoenix Contact Co. Ltd.	IC2.5/6-STF-5.08	
AL-00329458-01	CNC plug	Phoenix Contact Co. Ltd.	IC2.5/3-STF-5.08	
Low voltage circuit Connector set	AL-00292309	CN1,CN2 plug and housing	Sumitomo 3M Ltd.	10150-3000PE
				10350-52A0-008
				10120-3000PE
				10320-52A0-008
Low voltage circuit Connector set	AL-00416792	CNA,CNB,CNC plug	Phoenix Contact Co. Ltd.	MSTB2.5/5-STF-5.08
				IC2.5/3-STF-5.08
Amplifier capacity RS1□01 to RS1□05 Standard set	AL-00393603	CN1,CN2 plug and housing CNA,CNC plug	Sumitomo 3M Ltd. Phoenix Contact Co. Ltd.	10150-3000PE
				10350-52A0-008
				10120-3000PE
				10320-52A0-008
				MSTB2.5/5-STF-5.08
IC2.5/3-STF-5.08				
Amplifier capacity RS1□10, RS1□15, RS1□30 Standard set	AL-00292309	CN1,CN2 plug and housing	Sumitomo 3M Ltd.	10150-3000PE
				10350-52A0-008
				10120-3000PE
				10320-52A0-008

* CNB is installed in the servo amplifier. It is not included in the high-voltage circuit connector set.

AC100V input type

Application	Model number	Contents	Manufacturer	Manufacturer's model number
Single connector	AL-00329461-02	CNA plug	Phoenix Contact Co. Ltd.	MSTB2.5/4-STF-5.08
Amplifier capacity RS1□01 to RS1□03 Standard set	AL-00492384	CN1,CN2 plug and housing CNA,CNC plug	Sumitomo 3M Ltd. Phoenix Contact Co. Ltd.	10150-3000PE
				10350-52A0-008
				10120-3000PE
				10320-52A0-008
				MSTB2.5/4-STF-5.08
IC2.5/3-STF-5.08				

Setup software computer connecting cable

Model number	Remarks
AL-00490833-01	Dedicated cable

■ Metal mounting fittings

The servo amplifiers of RS□01,RS□03,RS□05 have metal mounting fittings of old compatible (PY2 series) available.

● Metal mounting fittings table for RS□01 to 05

Servo amplifier model number	Mounting Position	Model	Contents
RS1□01	Front	AL-00582788-01	Fitting metals:1 Tightning screw: 6
RS1□03	Front	AL-00582789-01	Fitting metals:1 Tightning screw: 2
RS1□01, RS1□03	Back	AL-00582791-01	Fitting metals:1 Tightning screw: 2
RS1□05	Front	AL-00582790-01	Fitting metals:1 Tightning screw: 6
	Back	AL-00582792-01	Fitting metals:1 Tightning screw: 2

Metal mounting fittings of this option employ three-number chromate plating treatment.
(Surface color: It is different from blue-silver/body color.)

● AL-00582788-01

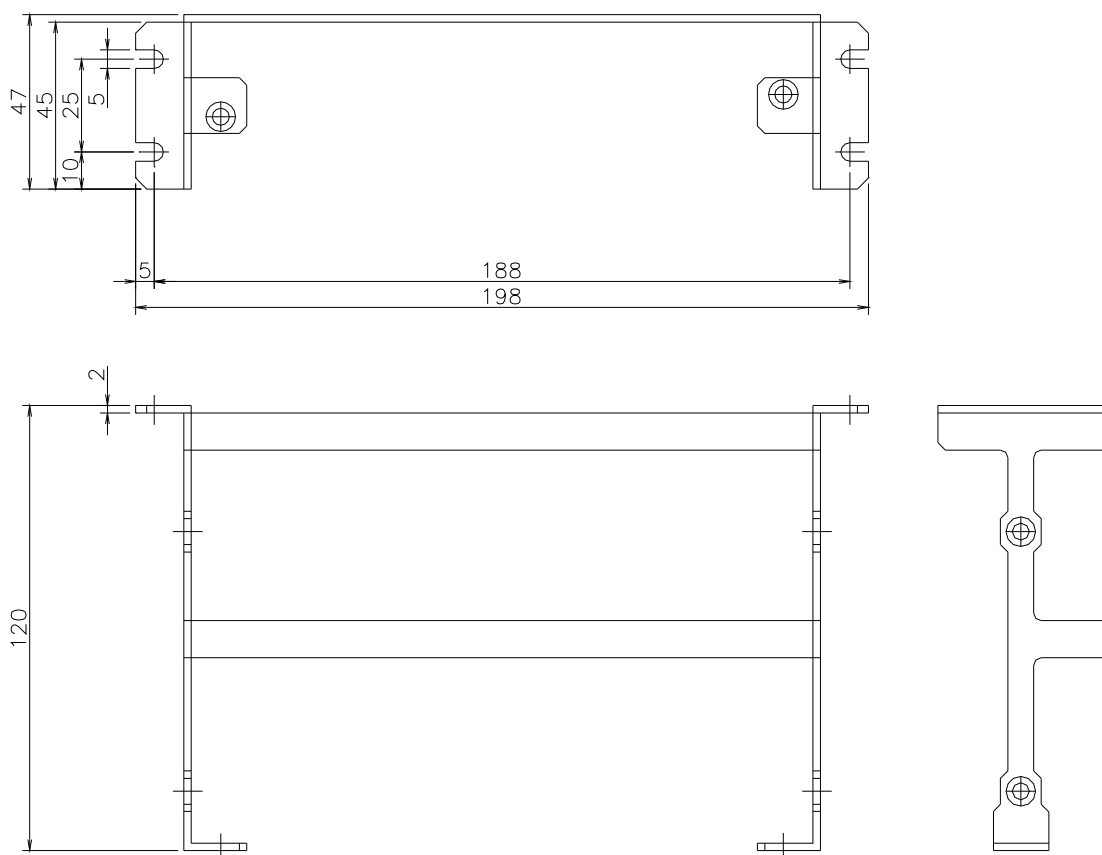

Materials: Optional parts

[Metal mounting fittings]

● AL-00582789-01

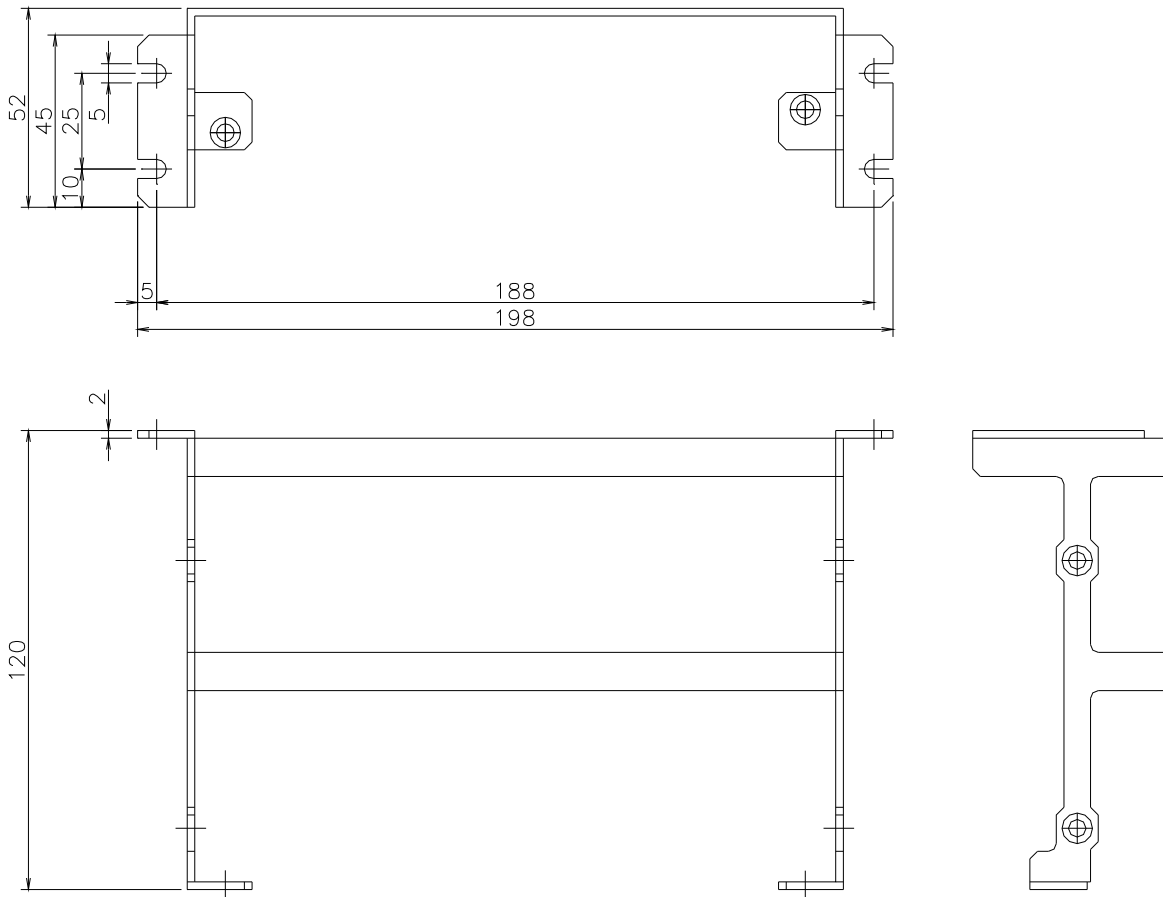

● AL-00582791-01

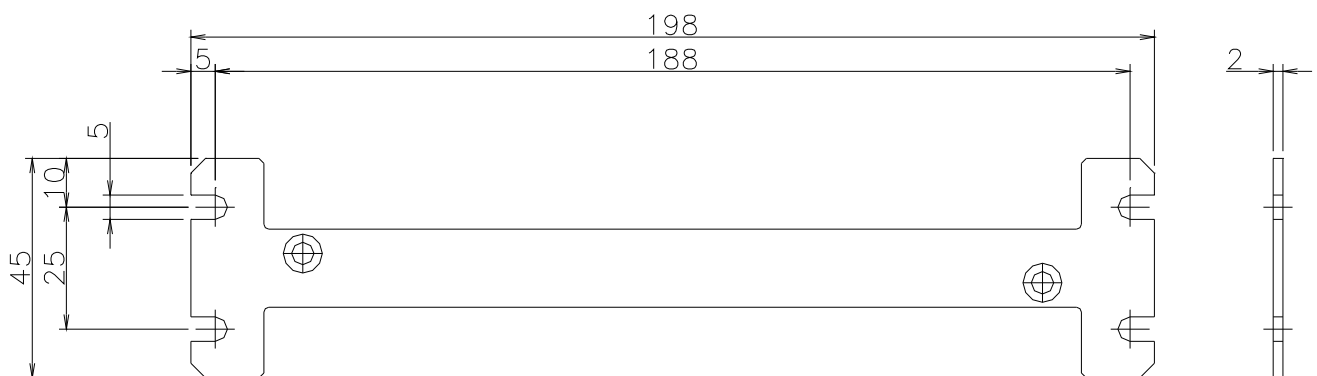

Materials: Optional parts

[Metal mounting fittings]

● AL-00582790-01

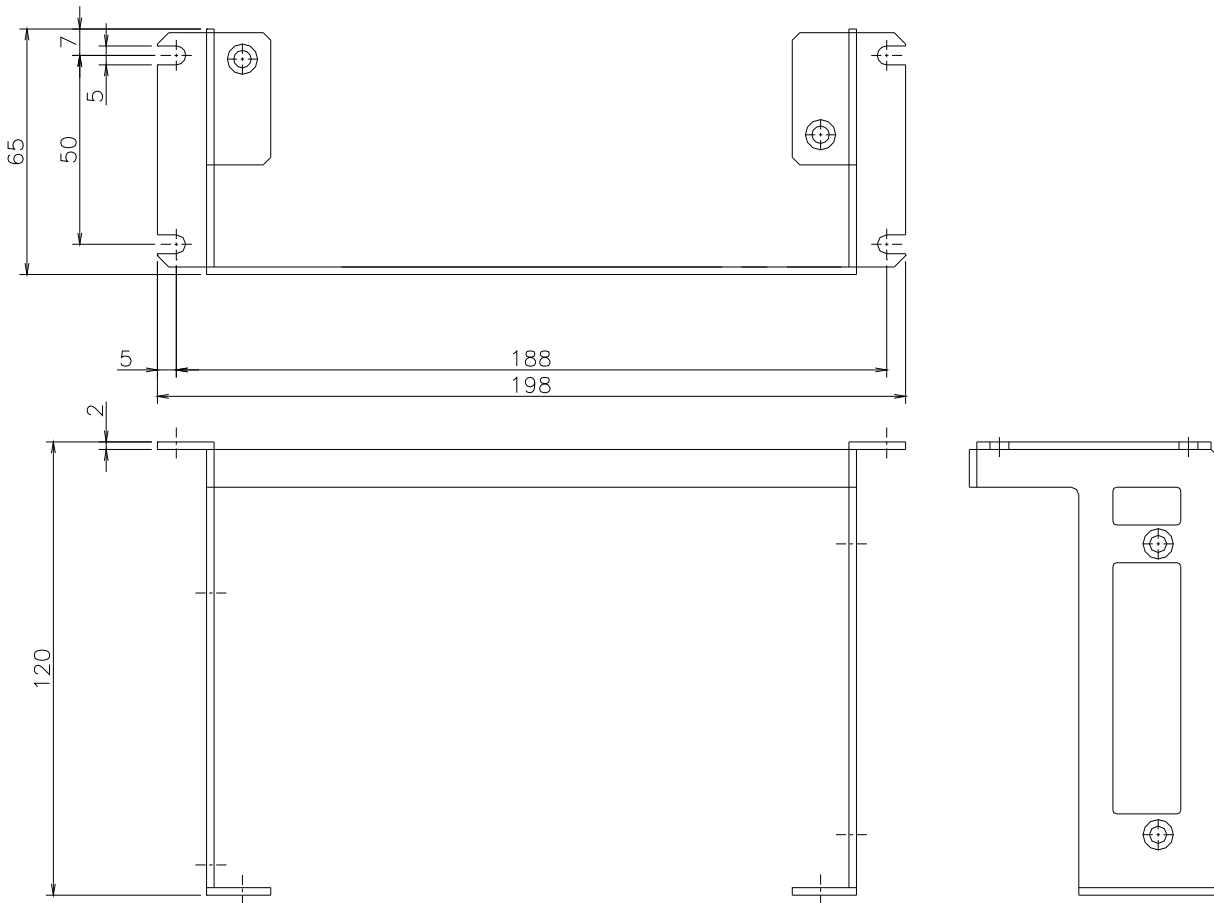

● AL-00582792-01

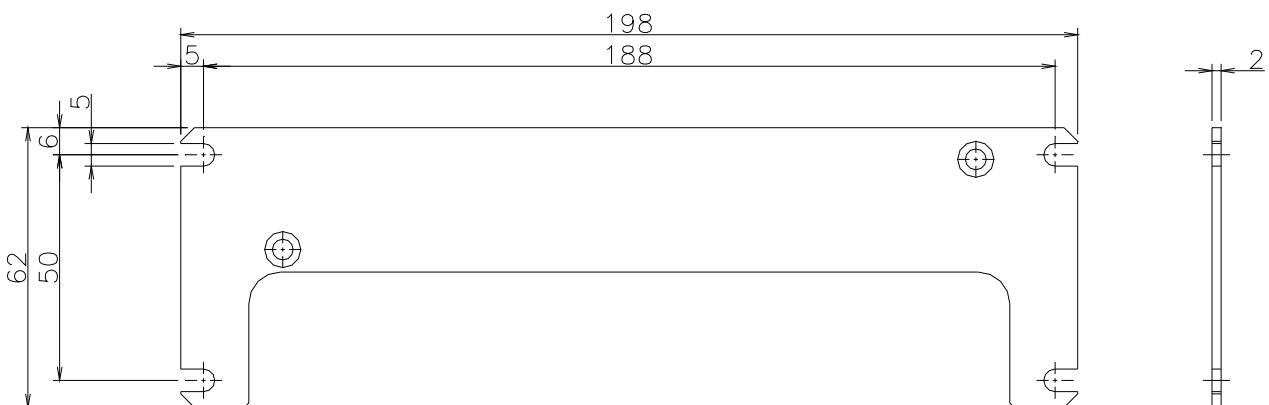

Materials: Optional parts

[Monitor box]

■ Monitor box

● Monitor box and dedicated cable

Model number	Remarks
Q-MON-1	Monitor box +Dedicated cables (2 cables)

Two dedicated cables blow come with this monitor box.

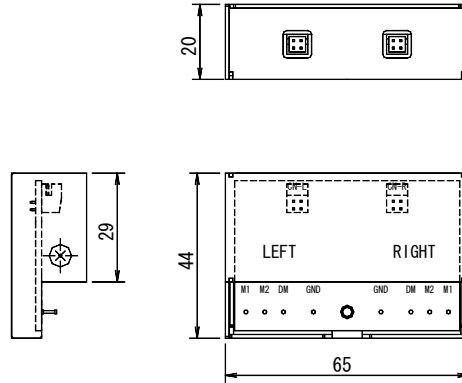

● Dedicated cables

Model number	Remarks
AL-00496726-01	Dedicated cables (1 cables)

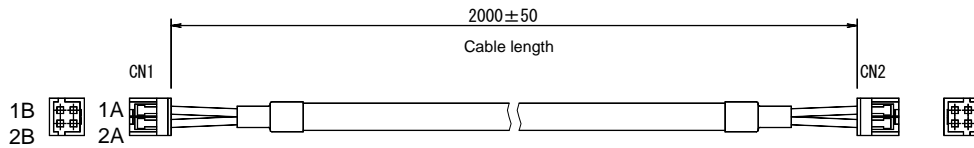

Terminal name	Function
1A	Analog monitor 1
1B	Analog monitor 2
2A	GND
2B	Digital monitor

	Manufacturer mdel number	Manufacturer
Connector	LY10-DC4	Japan Aviation Electronics Industry, Ltd.
Contact	LY10-C1-1-10000	Japan Aviation Electronics Industry, Ltd.

Materials: Optional parts

[Lithium battery · EMCKit]

■ Lithium battery

Model number	Remarks
AL-00494635-01	ER3VLY

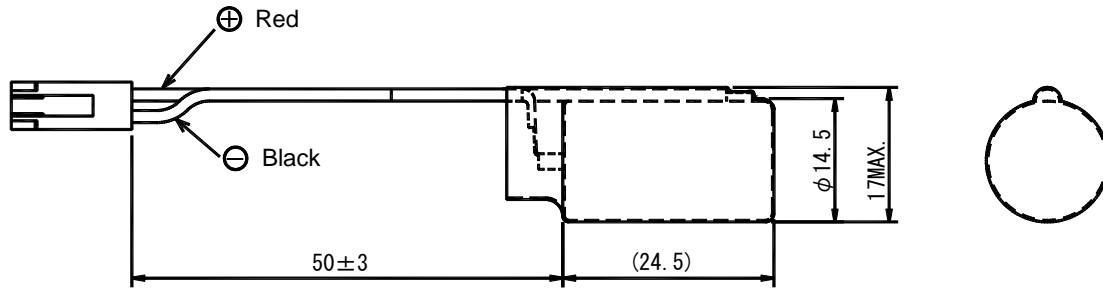

Mass: 0.02kg

	Manufacturer model number	Manufacturer
Connector	IL-2S-S3L-(N)	Japan Aviation Electronics Industry, Ltd.
Contact	IL-C2-1-10000	Japan Aviation Electronics Industry, Ltd.
Battery	ER3VLY	TOSHIBA HOME APPLIANCES CORPORATION.

■ EMC countermeasure kit

Model number	Remarks
QS-EMC-KIT1	Noise filter: 3SUP-HK30-ER-6B
	Toroidal core: 251-211

Model number: 3SUP-HK30-ER-6B

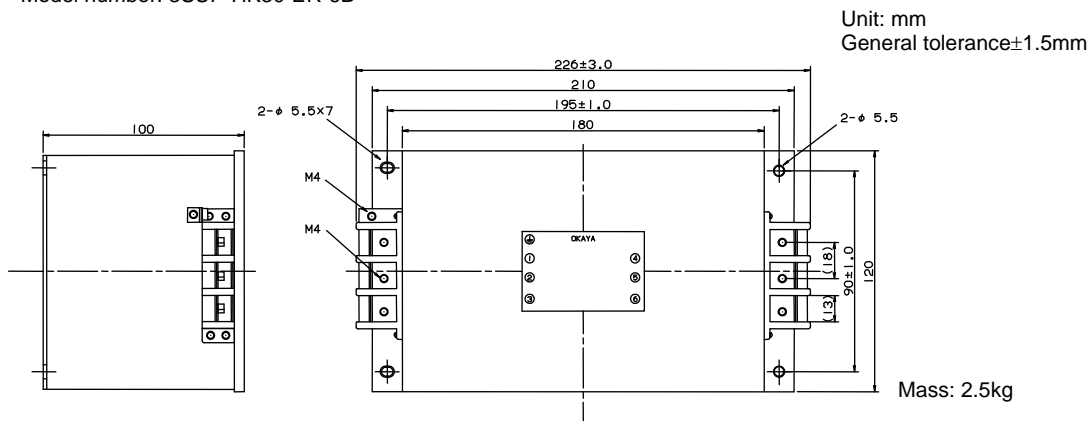

Model number: 251-11

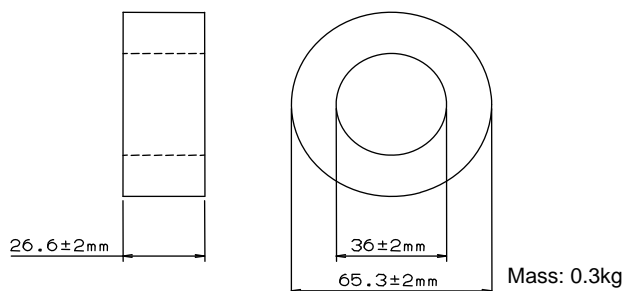

Materials Encoder clear

[Encoder clear/ reset method]

■ Encoder clear / Alarm reset method

'Encoder clear / alarm reset method' vary according to the encoder you use. Any alarms will not be reset under the procedure of the list below unless any alarm factors are removed by correction.

● Asynchronous encoder

Alarm code	Name		Encoder type	Encoder clear and alarm reset method
A2	Battery abnormal	→	PA035C	After'Encoder clear input' ⇒ 'Alarm reset input'
			RA062C	—
A3	Encoder overheat	→	PA035C	'Alarm reset input'
			RA062C	
A5	Abnormal encoder3	→	PA035C	—
			RA062C	Power restoration
A6	Abnormal encoder4	→	PA035C	—
			RA062C	Power restoration
A7	Abnormal encoder5	→	PA035C	—
			RA062C	Power restoration
A8	Abnormal encoder6	→	PA035C	—
			RA062C	Power restoration
A9	Encoder failure	→	PA035C	Power restoration
			RA062C	
B3	Numerous rotation abnormal	→	PA035C	Power restoration
			RA062C	
B4	One rotation abnormal	→	PA035C	Power restoration
			RA062C	—
B5	Over speed/ Numerous rotation abnormal	→	PA035C	After'Encoder clear input' ⇒ 'Power restoration' or 'Alarm reset input'
			RA062C	
B6	Memory abnormal	→	PA035C	After'Encoder clear input' ⇒ 'Power restoration' or 'Alarm reset input'
			RA062C	
B7	Acceleration abnormal	→	PA035C	—
			RA062C	After'Encoder clear input' ⇒ 'Power restoration'

● Manchester encoder

Alarm code	Name		Encoder type	Encoder clear and alarm reset method
A1	Encoder abnormal 1	→	RA062M	Power restoration
A2	Battery abnormal	→	ABS-E	After'Encoder clear input' ⇒ 'Alarm reset input'
B2	Encoder abnormal 2	→	RA062M	Power restoration

■ How to use electronic gear

This has a function which can set up the servo motor travel distance equivalent to position command pulse in accordance with the device.

For example: Set-up method when wiring-saving incremental encoder 2000[P/R] is used.

(1) Encoder pulse number equivalent of one rotation of servo motor is $2000[P/R] \times 4 \text{ times} = 8000[P/R]$

(2) Feed of command input pulse necessary to revolve once or move one revolution is $8000[P/R]$.

(3) Frequency of command input pulse necessary to operate the servo motor at 4800min^{-1} under this condition can be sought by the equation below.

$f = \frac{N}{60} \times \text{Encoder pulse [P/R]} \times 4\text{times}$	<p>f = Frequency of input pulse N = Revolution number to operate servo motor</p>
---	--

Frequency of the command input pulse necessary to operate the servo motor at 4800min^{-1} under the above condition is 640kHz .

(4) If operation is possible under this condition, set-up value of electronic gear will be $1/1$.

- Set-up value of electronic gear $1/1$
- Command input pulse feed per servo motor rotation $8000 [P/R]$
- Frequency of command input pulse necessary to operate the servo motor at 4800min^{-1} 640kHz

If it cannot be used under the above condition



For example:

You want to make command input pulse feed per servo motor revolution $500 [P/R]$

(1) Encoder pulse number equivalent of servo motor revolution is $2000 [P/R] \times 4\text{times} = 8000 [P/R]$.

(2) Command input pulse feed necessary to revolve servo motor once or move one revolution at this time is $8000 [P/R]$.

However, command input pulse feed must be $500 [P/R]$.

$$\frac{8000}{500} = \frac{16}{1} \text{ times are necessary.}$$

If set-up value of electronic gear is made to be $16/1$, command input pulse feed will be $500 [P/R] \times 16/1 \rightarrow 8000 [P/R]$

- Set-up value of electronic gear $16/1$
- Command input pulse feed per servo motor rotation $500 [P/R]$
- Frequency of command input pulse necessary to operate the servo motor at 4800min^{-1} $640\text{kHz}/(16/1)$ 40kHz

Materials: Abbreviated model number

[Setup contents]

■ Setup contents of each abbreviated model number

Factory default system parameters of each abbreviated model numbers, RS1A, RS1B, RS1L, and RS1M

Page	Name	Set-up value					
		RS1□01A*	RS1□03A*	RS1A□05A*	RS1A□10A*	RS1□15A*	RS1□30A*
--	Amplifier capacity	15_Ampere	30_Ampere	50_Ampere	100_Ampere	150_Ampere	300_Ampere
--	Motor structure	Rotary_Motor					
--	Control power input voltage	200V Class					
--	Control power input class	AC Single-Phase					
--	Main circuit power input voltage	200V Class					
00	Main circuit power input class	00:_AC_3-Phase					
01	Motor encoder type	If * is A, B or T, 00:_Incremental_ENC If * is H or R, 01:_Absolute_ENC					
02	Incremental encoder function selection	00:_Standard					
03	Incremental encoder resolution	If * is A, B or T or H,2000 If * is R,2048					
04	Absolute encoder function selection	If * is A, B or T, 04:_PA035C-2.5MH_Manu If * is H, 80:_RA062M-1MF. If * is R, 84:_ABS-E.					
05	Absolute encoder resolution	If * is A, B or T or R, 00:_2048_FMT If * is H, 04:_32768_FMT					
06	Combination motor model number	P50B03003D	P50B07040D	P50B08075D	P60B13200H	P80B22350H	P60B18750R
08	Control mode	01:_Velocity					
09	Position loop control · Position loop encoder selection	If * is A, B or H or R, 00:_Motor_Encoder If * is T, 01:_Ext-ENC					
0A	External encoder resolution	2000					
0B	Regenerative resistance selection	If <input type="checkbox"/> is A or B, 02:_External_R If <input type="checkbox"/> is L or M, 01:_Built-in_R	If <input type="checkbox"/> is A or B, 01:_Built-in_R If <input type="checkbox"/> is L or M, 02:_External_R			If <input type="checkbox"/> is A or B, 02:_External_R There is no setting <input type="checkbox"/> to L or M.	

Factory default system parameters of each abbreviated model numbers, RS1E, RS1F, RS1N, and RS1P

Page	Name	Set-up value			
		RS1E01A* RS1F01A*	RS1E03A* RS1F03A*	RS1N01A* RS1P01A*	RS1N03A* RS1P03A*
--	Amplifier capacity	15_Ampere	30_Ampere	15_Ampere	30_Ampere
--	Motor structure	Rotary_Motor			
--	Control power input voltage	100V Class			
--	Control power input class	AC Single-Phase			
--	Main circuit input voltage	100V Class			
00	Main circuit input class	01:_AC_Single-Phase			
01	Motor encoder type	If * is A, B or T, 00:_Incremental_ENC If * H or R, 01:_Absolute_ENC			
02	Incremental encoder function selection	00:_Standard			
03	Incremental encoder resolution	If * is A, B or T or H,2000 If * is R,2048			
04	Absolute encoder function selection	If * is A, B or T, 04:_PA035C-2.5MH_Manu If * is H, 80:_RA062M-1MF If * is R, 84:_ABS-E			
05	Absolute encoder resolution	If * is A, B or T or R, 00:_2048_FMT If * is H, 04:_32768_FMT			
06	Combination motor model number	P50B03003P	P50B05020P	P50B03003P	P50B05020P
08	Control mode	01:_Velocity			
09	Position loop control · Position loop encoder selection	If * is A, B or H or R, 00:_Motor_Encoder If * is T, 01:_Ext-ENC			
0A	External encoder resolution	2000			
0B	Regenerative resistance selection	02:_External_R		01:_Built-in_R	

Memo

A

Absolute encoder clear function	7-38
Absolute position data output circuit	3-18
Acceleration time	5-19, Materials-1
Adjustment method of disturbance observer	7-5
Adjustment method of high setting control	7-6
Adjustment method of notch filter	7-5
Adjustment method of vibration suppressing control	7-5
Adjustment mode(Digital operator)	4-11
Alarm history clear method(Digital operator)	4-13
Alarm list	8-3
Alarm reset function	7-26
Alarm reset sequence	6-12
Alarm sequence	6-11
Alarm trace	4-15
Alarm trace mode(Digital operator)	4-15
Ambient humidity(Servo-motor)	2-4, 9-23
Ambient temperature	2-4, 9-1
Analog command input	3-15
Analog input circuit	3-15
Analog monitor	3-20, 5-4, 5-27, 5-29, 7-39
Analog torque addition function	7-17
Analog torque command input	7-15
Analog velocity (addition) command scaling	7-15
Auto-adjustment mode	4-11
Automatic offset adjustment of torque command	4-11

B

Battery input circuit	3-16
Battery space	8-26
Battery warning function	4-4
Built-in regeneration resistor	Materials-7
Brake function and sequence	6-10
Brake operation beginning time(BONBGN)	7-33

C

Calculation Method of Regeneration Power	Materials-8
Calorific value	9-3
CE	Materials-20
Characteristic table(Servo-motor)	Materials-41
Circuit breaker	3-1, 3-26
CN1 connector terminal layout	3-11, 3-12
CN1, 2 Wire diameter	3-28
CN2 Connector terminal layout	3-21
CN2 terminal layout	3-21
Command polarity reversed	7-7
Command pulse multiplier	5-17
Compliance with EC directive	Materials-20
Confirmation method of regeneration power(Actual operation)	Materials-10
Control function	9-1
Control mode changed	5-33
Control mode switching function	7-27
Control panel	Materials-21
Control power wire diameter	3-28
Control system	9-1
Connection of regenerative resistance	Materials-12
Connector(Option)	3-30
Connector terminal number	3-12
Corrective actions for problems during operation	8-1
CPU software version(Digital operator)	4-15
Current leakage	9-2
Current loop	7-4

D

Data sheet(Servo-motor)	Materials-41
Deceleration time	7-16, Materials-1
Delay time of engaging holding brake(BONDLY)	7-32
Delay time of releasing holding brake(BOFFDLY)	7-33
Deviation clear selection	7-12
Description of test run mode(Digital operator)	4-12
Digital monitor	7-40
Digital operator name	4-1
Dimension(Servo-amplifier)	Materials-24
Dominant mode(Digital operator)	4-1
Dynamic brake action selection	7-31
Dynamic brake constant table	Materials-6
Dynamic brake delay time	Materials-4

E

Electric gear	7-11, Materials-72
Electromagnetism contactor	3-1, 3-26
Elevation	9-1
Emergency stop function(EMR)	7-30
Emergency stop operation(EMR)	7-31, 7-33
Encoder clear, Alarm reset method	Materials-71
Encoder output pulse divided ratio	7-37
Encoder pulse divided output	7-37
Encoder pulse divided output polarity	7-38
Encoder pulse divided output selection	7-37
Encoder resolution setting	6-5
Encoder signal output format	9-5
Encoder signal phases	9-23
Encoder type setting(INC ↔ ABS)	6-5
Environment	2-4, 8-26, 9-1
External dimension of regenerative resistor	Materials-15
External encoder digital filter	7-36
External encoder polarity invert	7-36
External encoder polarity invert function	7-36
External encoder resolution setting	6-5
External error input	7-30
External regenerative resistor combination	Materials-13
External torque limit	7-18

F

FFFIL	5-9, 7-4
FFGN	5-9, 7-4
Following error limit	7-35
Following error warning	7-35
Free-Run is operated	5-27, 7-25, 7-31
Full-closed	3-25

G

Gain switching function(Adjusting method)	7-6, 7-28
General parameter list	5-1
General specifications	9-1
Generic input circuit	3-17
Generic input signals	5-23, 5-28
Generic output	3-19

H

Holding brake function	5-28
Holding brake specifications	9-26
Holding brake excitation signal and sequence	6-10
How to replace absolute encoder buck-up battery	8-26
How to set the system parameter mode(Digital operator)	4-14

I

Imposition/Position deviation monitor	7-11
Incoming current	9-2
Incremental encoder digital filter	7-36
Incremental pulse signal output circuit	3-18
Industrial waste	5
In-Position near range	7-21
Input key function(Digital operator)	4-1
Input/Output connector(Optional)	3-1, Materials-65
Input power	9-1
In-Rush current preventing	6-12
Installation and wiring	6-3
Installation metal fittings	Materials-66
Instantaneous load tolerance dynamic brake	Materials-5
Interpretation of servo amplifier model number	1-4
Interpretation of servo motor model number	1-2
Internal torque limit function	7-18
International standards certificate number	Materials-18
International standards file number	Materials-18

J

JOG driving(Servo-motor)	6-2
JOG operation	6-7
JRAT	7-5

K

KP	7-4
KVP	7-4

L

Line driver output circuit	3-13, 7-8
List of monitors display(Monitor)	7-40
Load inertia ratio	7-5
Low speed range	7-23

M

Main power discharge function	7-30
Main power input	5-32
Main power wire diameter	3-28
Maintenance	8-1
Mass(Servo-amplifier)	9-1
Materials dimension(Servo-motor)	Materials-30
Mechanical specifications	9-24
Mechanical strength(Servo-motor)	9-25
Method of editing parameter (Digital operator)	4-9
MODE KEY(Digital operator)	4-1
Monitor box	Materials-69
Monitor mode(Digital operator)	4-4
Motor-Free is operated	7-31
Mounting method(Servo-amplifier)	2-3
Mounting method(Servo-motor)	2-4

N

NEAR	7-21
Noise filter	Materials-21, 22
Noise processing	Materials-21
Notch filter tuning	5-8, 7-5
NPN (Sink) output	3-7, 3-8, 3-13, 3-19

O

Oil seal	9-25
Open collector	3-16, 7-8, 7-37
Operation sequence	6-10
Option	Materials-65
Option external regenerative resistor	Materials-11
Origin Z phase output circuit	3-18
Over load characteristics	Materials-56
Overload warning	7-35
Over travel function	7-25

P

Packaged wiring diagram	3-1
Parameter list	5-1
Parameter saved(Auto tuning)	7-3
Parts overhaul	8-25
Password function	4-16
PCFIL	5-9, 7-4
Peripherals	3-26
Permitted repetitions	Materials-1
Photo coupler input	3-17, 3-19
PNP (Source) output	3-9, 3-10, 3-14, 3-19, 3-20
Position command input circuit	3-16
Position command maximum input pulse frequency	9-1
Position command pulse	7-8
Position command pulse count polarity	7-9
Position command pulse digital filter	7-9
Position command pulse inhibit function	7-27
Position command pulse input circuit	3-15
Position command timing	5-17
Position deviation clear	5-18
Positioning method	7-11
Position loop control and encoder selection	5-33
Position loop proportional control switching function	7-29
Position signal output	3-18
Position signal pulse output	9-4
Power capacity	3-26
Power failure detection delay time function	7-34
P-PI Automatic change function	7-29
Precautions when installing	2-1
Preset velocity compensation command	7-15, 7-17
Procedure until driving	6-1
Product verification	1-1
Proportional control	7-29
Protection function of regenerative resistor	Materials-14
Protective circuit	3-7
Protective ground terminal	1-8, Materials-22
Pulse output	9-4

Q

R

Radial	2-8
Recommended prevention components(EMC)	Materials-70
Regeneration process	Materials-7
Regenerative overload warning status	4-4, 5-29
Rotation direction specification	9-23

S

Safety Precautions	1
Selection	Materials-1
Semi-closed	5-33
Serial output	9-5, 9-11, 9-16, 9-21
Serial output(Absolute encoder)	9-5
Serial output(Absolute encoder with incremental output)	9-11
Serial output(Request method absolute encoder)	9-16
Serial output(Wire-saving incremental encoder)	9-21
Servo adjustment parameters	7-4
Servo amplifier part names	1-8
Servo-Brake	5-27, 6-11, 7-20, 7-25, 7-31
Servo-motor characteristics table	Materials-41
Servo-motor dimension	Materials-30
Servo-motor general specification	9-23
Servo motor stop operation	7-25, 7-31
SERVO-ON Function	5-22, 7-26
Servo system structure	7-4
Setting the positioning completion signal	7-22
Shock	9-1, 9-24
Shock resistance(Servo-motor)	9-24
Shortened model number(Servo-amplifier)	Materials-73
Size of electric wire	3-29
Speed command voltage	9-1
Speed matching width	7-23
Speed transport settings	7-23
Status display mode(Digital operator)	4-3
Storage humidity	9-1
Storage temperature	9-1
Surge protector	3-1, 3-27
Structure of tuning	7-1
System parameter	5-7

T

TCFIL	5-10, 7-5
TCNFIL/A/B	5-11
Thrust load	2-8
Toroidal core	Materials-23
Torque command input impedance	9-1
Torque command voltage	9-1
Torque compensation function	7-17
Torque limit function	7-18
Torque limit at sequence operation	7-20
Trouble shooting when alarm rings	8-1
Tuning method selecting procedure	7-2
TVI	5-9, 7-5
TUV	Materials-18

U

UL	Materials-18
----	--------------

V

VCFIL	5-9, 7-4
Velocity command Acceleration time constant	7-16
Velocity command deceleration time constant	7-16
Velocity command zero clamp function	7-27
Velocity compensation addition function	7-15
velocity input impedance	3-15, 9-1
Velocity limit	7-16
Velocity loop	7-4
Velocity loop proportional control switching function	7-29
Vibration classification(Servo-motor)	9-23
Vibration resistance(Servo-motor)	9-24
Vibration(Servo-amplifier)	9-1
Vibration suppressor frequency select	7-28
Velocity-torque characteristics	Materials-47

W

Working accuracy(Servo-motor)	9-24
-------------------------------	------

X

Y

Z

Release	
Revision C	Dec. 2005
Revision E	Nov. 2007
Revision F	Jul. 2008
Revision G	Sep. 2008
Revision H	Oct. 2008
Revision J	May. 2009
Revision K	Jan. 2010
Revision L	Dec. 2013



■ECO PRODUCTS

Sanyo Denki's ECO PRODUCTS are designed with the concept of lessening impact on the environment in the process from product development to waste. The product units and packaging materials are designed for reduced environmental impact. We have established our own assessment criteria on the environmental impacts applicable to all processes, ranging from design to manufacture.

■Precautions For Adoption

Failure to follow the precautions on the right may cause moderate injury and property damage, or in some circumstances, could lead to a serious accident.

Always follow all listed precautions.

⚠ Cautions

- Read the accompanying Instruction Manual carefully prior to using the product.
- If applying to medical devices and other equipment affecting people's lives please contact us beforehand and take appropriate safety measures.
- If applying to equipment that can have significant effects on society and the general public, please contact us beforehand.
- Do not use this product in an environment where vibration is present, such as in a moving vehicle or shipping vessel.
- Do not perform any retrofitting, re-engineering, or modification to this equipment.
- The Products presented in this Instruction Manual are meant to be used for general industrial applications. If using for special applications related to aviation and space, nuclear power, electric power, submarine repeaters, etc., please contact us beforehand.

* For any question or inquiry regarding the above, contact our Sales Department.

SANYO DENKI CO., LTD.

3-33-1, Minami-Otsuka, Toshima-ku, Tokyo, 170-8451, Japan TEL: +81 3 5927 1020 FAX: +81 3 5952 1600

SANYO DENKI AMERICA, INC.

468 Amapola Avenue Torrance, CA 90501, U.S.A.

SANYO DENKI EUROPE SA.

P.A. Paris Nord II, 48 Allée des Erables-VILLEPINTE, BP.57286, F-95958 ROISSY CDG Cedex, France

SANYO DENKI GERMANY GmbH

Frankfurter Strasse 92, 65760 Eschborn, Germany

SANYO DENKI KOREA CO., LTD.

9F 5-2, Sunwha-dong Jung-gu Seoul, 100-130, Korea

SANYO DENKI SHANGHAI CO., LTD.

Room 2107-2109, Bldg A, Far East International Plaza, No.319, Xianxia Rd., Shanghai, 200051, China

SANYO DENKI TAIWAN CO., LTD.

Room 1208, 12F, No. 96, Chung Shan N, Rd., Sec.2, Taipei 104, Taiwan, R.O.C.

SANYO DENKI (H.K.) CO., LIMITED

Room 2305, 23/F, South Tower, Concordia Plaza, 1 Science Museum Rd., TST East, Kowloon, Hong Kong

SANYO DENKI SINGAPORE PTE.LTD.

10 Hoe Chiang Road, #14-03A/04, Keppel Towers Singapore 089315

<http://www.sanyodenki.co.jp>

<http://www.sanyo-denki.com>

TEL: +1 310 783 5400

<http://www.sanyodenki.eu>

TEL: +33 1 48 63 26 61

<http://www.sanyodenki.de>

TEL: +49 6196 76113 0

<http://www.sanyodenki.co.kr>

TEL: +82 2 773 5623

<http://www.sanyodenki.biz>

TEL: +86 21 6235 1107

<http://www.sanyodenki.com.tw>

TEL: +886 2 2511 3938

<http://www.sanyodenki.com.hk>

TEL: +852 2312 6250

<http://www.sanyodenki.com.sg>

TEL: +65 6223 1071

The names of companies and/or their products specified in this manual are the trade names, and/or trademarks and/or registered trademarks of such respective companies.

*Remarks : Specifications are subject to change without notice.