

# Pressure relief valve, direct operated

**RE 25402/02.09**  
Replaces: 08.08

1/16

## Type DBD

Sizes 6 to 30  
Component series 1X  
Maximum operating pressure 630 bar [9150 psi]  
Maximum flow 330 l/min [87 US gpm]



## Table of contents

Contents	Page
Features	1
Ordering code	2, 3
Function, section, symbol	4
Technical data	5
General notes	5
Characteristic curves	6
Unit dimensions: Threaded connection	7
Unit dimensions: Cartridge valve	8, 9
Unit dimensions: Subplate mounting	10, 11
<b>Type-tested safety valves</b>	
<b>type DBD../..E, component series 1X,</b>	
<b>to Pressure Equipment Directive 97/23/EC</b>	
(in the following, PED in short)	
Ordering code	12
Unit dimensions	12
Technical data	13
Characteristic curves	13
Safety notes	14 to 16

## Features

- As screw-in cartridge valve
- For threaded connection
- For subplate mounting
- Adjustment types for pressure adjustment, optional:
  - Sleeve with hexagon and protective cap
  - Rotary knob / hand wheel
  - Lockable rotary knob

Information on available spare parts:  
[www.boschrexroth.com/spc](http://www.boschrexroth.com/spc)

## Ordering code

								DBD				1X/
Pressure relief valve, direct operated												
<b>Type of adjustment for pressure adjustment</b>								Size				
	6	8	10	15	20	25	30					
Sleeve with hexagon and protective cap	●	●	●	●	●	●	●	= S				
Rotary knob <sup>1)</sup>	●	●	●	●	●	-	-	= H				
Hand wheel <sup>2)</sup>	-	-	-	-	-	●	●	= H				
Lockable rotary knob <sup>1,3,5)</sup>	●	●	●	●	●	-	-	= A				
<b>Size</b> (Port)	= 6 G1/4	= 8 G3/8	= 10 G1/2	= 15 G3/4	= 20 G1	= 25 G1 1/4	= 30 G1 1/2	E.g. = 10				
<b>Type of connection</b>												
As screw-in cartridge valve	●	-	●	-	●	-	●	= K				
For threaded connection <sup>4)</sup>	●	●	●	●	●	●	●	= G				
For subplate mounting	●	-	●	-	●	-	●	= P				
Component series 10 to 1Z (10 to 1Z: unchanged installation and connection dimensions)										= 1X		
<b>Pressure rating <sup>6)</sup></b>												
Pressure setting up to 25 bar [362 psi]	●	●	●	●	●	●	●	= 25				
Pressure setting up to 50 bar [725 psi]	●	●	●	●	●	●	●	= 50				
Pressure setting up to 100 bar [1450 psi]	●	●	●	●	●	●	●	= 100				
Pressure setting up to 200 bar [2900 psi]	●	●	●	●	●	●	●	= 200				
Pressure setting up to 315 bar [4568 psi]	●	●	●	●	●	●	●	= 315				
Pressure setting up to 400 bar [5800 psi]	●	●	●	●	●	-	-	= 400				
Pressure setting up to 630 bar [9150 psi] <sup>7)</sup>	-	-	●	-	-	-	-	= 630				

● = Available

For explanation of footnotes, see page 3!

			*		
					Further details in clear text
					<b>PED</b>
					Without type examination
					Type-tested safety valve in accordance with PED 97/23/EC
					<b>Pipe connection</b>
					Pipe thread to ISO 228/1
					SAE thread
					<b>Seal material</b>
					NBR seals
					FKM seals
					(other seals on request)
					<b>Attention!</b>
					Observe compatibility of seals with hydraulic fluid used!

- 1) With sizes 15 and 20, only available for pressure ratings 25, 50 or 100 bar.
- 2) Only available for pressure ratings 25, 50 or 100 bar.
- 3) Key with Material no. **R900008158** is included in the scope of supply.
- 4) Not available for type-tested safety valves of sizes 8, 15 and 25.
- 5) Not available for type-tested safety valves.
- 6) For the selection of the pressure rating, please observe the characteristic curves and notes on page 6!
- 7) For versions "G" and "P", only available as "SO292", see pages 7 and 10!

**Standard types and components are shown in the EPS (standard price list).**

## Function, section, symbol

Pressure relief valves of type DBD are direct operated seat valves.

They serve to limit a system pressure.

These valves basically consist of sleeve (1), spring (2), poppet with damping piston (3) (pressure rating 25 to 400 bar) or ball (4) (pressure rating 630 bar) and adjustment element (5). The system pressure setting can be infinitely varied by means of adjustment element (5). Spring (2) presses poppet (3) or ball (4) onto its seat. Channel P is connected to the system. The pressure prevailing in the system acts on the poppet area (or ball).

When the pressure in channel P rises above the value set on spring (2), poppet (3) or ball (4) opens against spring (2). Hydraulic fluid can now flow from channel P into channel T. The stroke of poppet (3) is limited by embossment (6).

To obtain good pressure settings over the entire pressure range, the entire pressure range was subdivided into 7 pressure ratings. A pressure rating corresponds to a certain spring, which can be used for setting a maximum operating pressure.

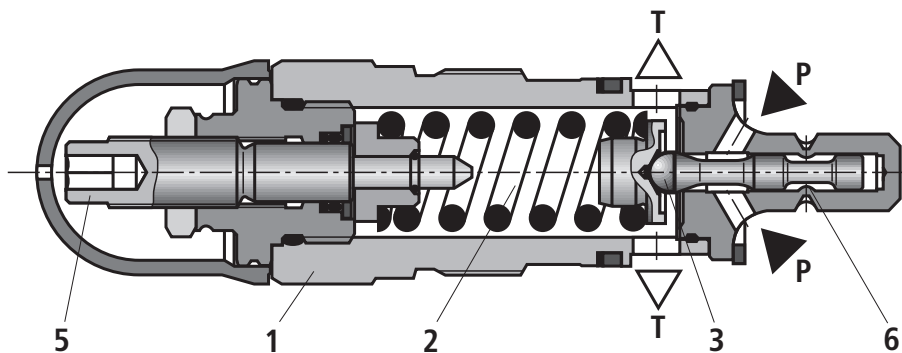

**Type DBDS..K1X/...**

Version for pressure rating 25 to 400 bar (poppet seat valve)

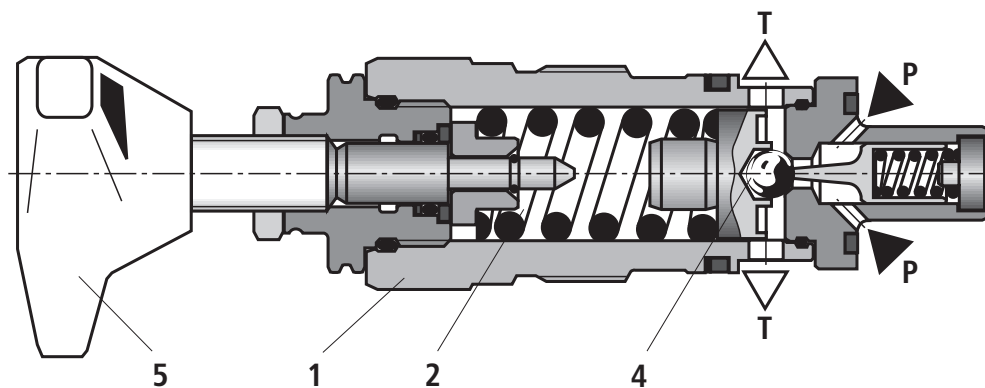

**Type DBDH 10 K1X/...**

Version for pressure rating 630 bar (ball seat valve, NG10 only)

### Symbol

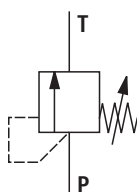

## Technical data (for applications outside these parameters, please consult us!)

### General

Size	NG	6 and 8	10	15 and 20	25 and 30
Weight	See pages 7, 9 and 11				
Installation position	Optional				
Ambient temperature range	°C [°F]	-30 to +80 [-22 to +176] (NBR seals) -15 to +80 [5 to 176] (FKM seals)			
Minimum strength of housing materials	Housing materials must be selected so that sufficient safety is provided under all conceivable operating conditions (e.g. with regard to compressive strength, thread stripping strength and tightening torques).				

### Hydraulic

Maximum operating pressure	- Inlet	bar [psi]	400 [5800]	630 [9150]	400 [5800]	315 [4568]
	- Outlet	bar [psi]	315 [4568]	315 [4568]	315 [4568]	315 [4568]
Maximum flow (standard valves)	See characteristic curves on page 6					
Hydraulic fluid	Mineral oil (HL, HLP) to DIN 51524 <sup>1)</sup> ; fast bio-degradable hydraulic fluids to VDMA 24568 (see also RE 90221); HETG (rape seed oil) <sup>1)</sup> ; HEPG (polyglycols) <sup>2)</sup> ; HEES (synthetic esters) <sup>2)</sup> ; other hydraulic fluids on request					
Hydraulic fluid temperature range	°C [°F]	-30 to +80 [-22 to +176] (NBR seals) -15 to +80 [5 to 176] (FKM seals)				
Viscosity range	mm <sup>2</sup> /s [SUS]	10 to 800 [60 to 3710]				
Permissible max. degree of contamination of the hydraulic fluid - cleanliness class to ISO 4406 (c)	Class 20/18/15 <sup>3)</sup>					

<sup>1)</sup> Suitable for NBR and FKM seals

<sup>2)</sup> Suitable **only** for FKM seals

<sup>3)</sup> The cleanliness classes specified for components must be adhered to in hydraulic systems. Effective filtration prevents malfunction and, at the same time, prolongs the service life of components.

For the selection of filters, see data sheets RE 50070, RE 50076, RE 50081, RE 50086, RE 50087 and RE 50088.

For deviating technical data for type-tested safety valves, see page 13.

### General notes

Hydraulic backpressures in port T add 1:1 to the response pressure of the valve set by means of the adjustment element.

#### Example:

- Pressure adjustment of the valve by means of spring pre-tensioning (item 2 on page 4)  $p_{\text{spring}} = 200 \text{ bar}$

- Hydraulic backpressure in port T:  
 $p_{\text{hydraulic}} = 50 \text{ bar}$

⇒ response pressure =  $p_{\text{spring}} + p_{\text{hydraulic}} = 250 \text{ bar}$

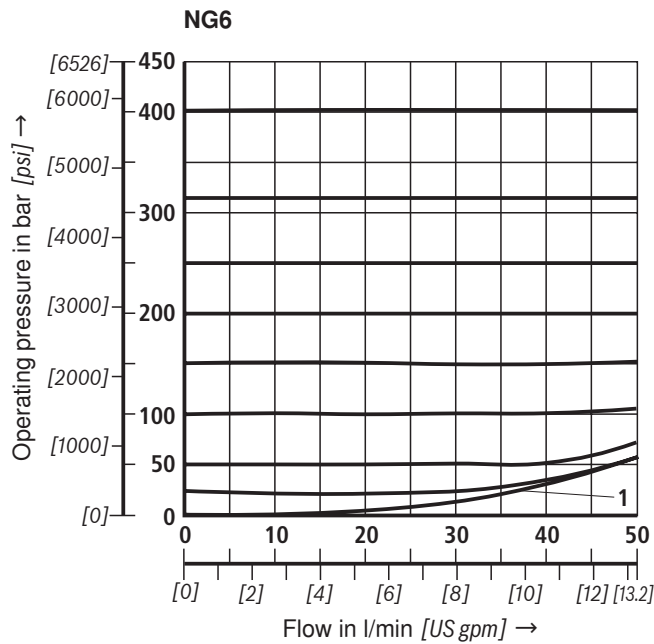
**Characteristic curves** (measured with HLP46,  $\vartheta_{oil} = 40 \text{ }^\circ\text{C} \pm 5 \text{ }^\circ\text{C}$  [ $104 \text{ }^\circ\text{F} \pm 9 \text{ }^\circ\text{F}$ ])

1 = lowest settable pressure

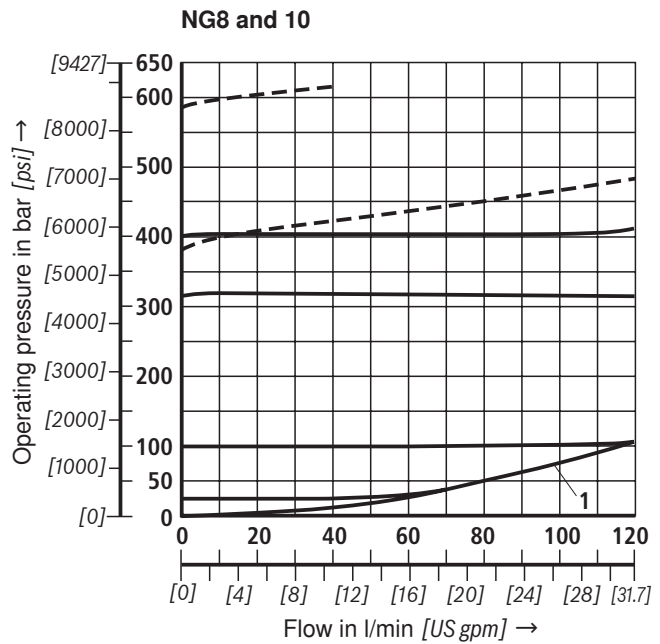

----- = Pressure rating 630 bar  
[9150 psi] (NG10 only)

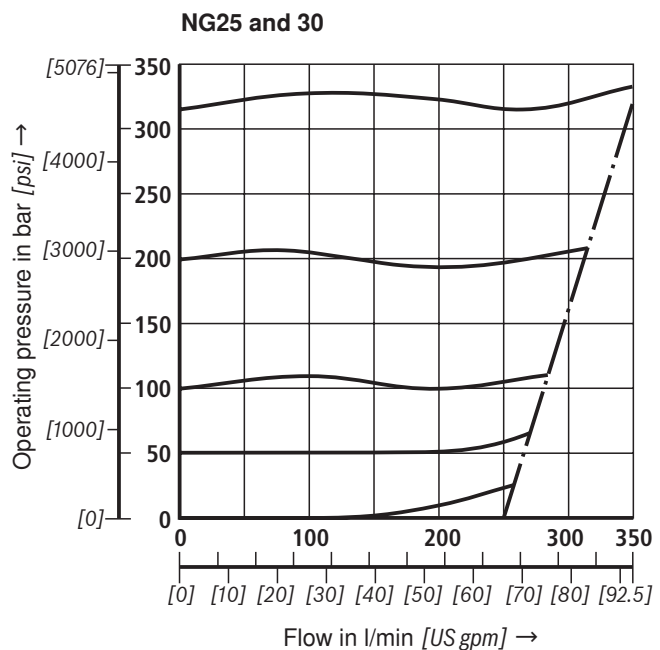
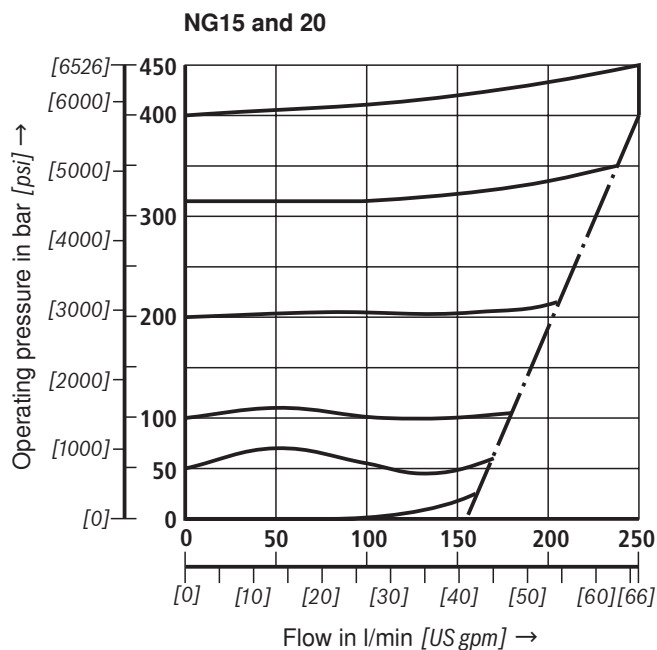
**Attention!**

- The characteristic curves are valid for output pressure = zero over the entire flow range and were measured without housing resistance!
- The characteristic curves are only valid under the specified ambient and temperature conditions. It must be noted that deviations in the boundary conditions have an influence on the characteristic curve!
- The characteristic curves refer to the given pressure ratings (e.g. 200 bar). The greater the difference between the set pressure value and the nominal pressure rating (e.g. < 200 bar), the greater is the pressure increase as the flow rises.

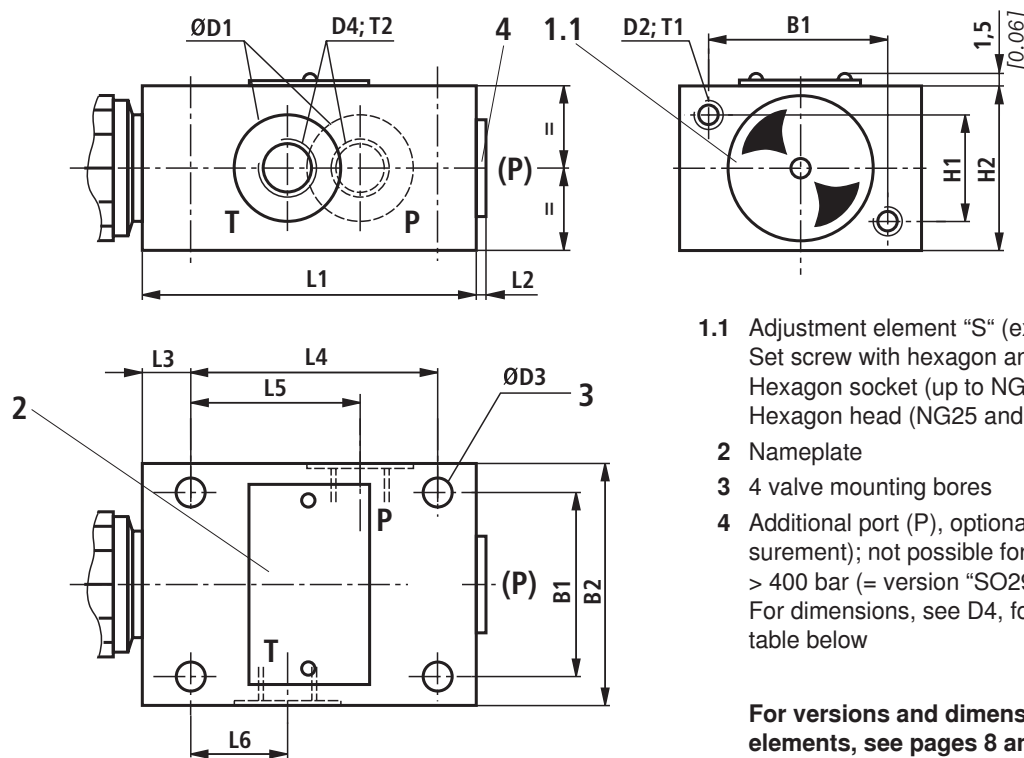
**Unit dimensions: Threaded connection (dimensions in mm [inch])**

- 1.1** Adjustment element "S" (example)  
Set screw with hexagon and protective cap;  
Hexagon socket (up to NG20)  
Hexagon head (NG25 and 30)
- 2** Nameplate
- 3** 4 valve mounting bores
- 4** Additional port (P), optional (e.g. for pressure measurement); not possible for NG10, pressure rating > 400 bar (= version "SO292").  
For dimensions, see D4, for tightening torques, see table below

**For versions and dimensions of the adjustment elements, see pages 8 and 9**

NG	B1	B2	ØD1	D2	ØD3	D4	Tightening torques $M_A$ in Nm [ft-lbs] for screws <sup>1)</sup>	
							Plug screw (4)	Pipe fittings
6	45 [1.77]	60 [2.36]	25 [0.98]	M6	6,6 [0.26]	G1/4	30 [22]	60 [44]
8	60 [2.36]	80 [3.15]	28 [1.10]	M8	9 [0.35]	G3/8	40 [29]	90 [66]
10	60 [2.36]	80 [3.15]	34 [1.34]	M8	9 [0.35]	G1/2	60 [44]	130 [95]
15	70 [2.76]	100 [3.94]	42 [1.65]	M8	9 [0.35]	G3/4	80 [59]	200 [147]
20	70 [2.76]	100 [3.94]	47 [1.85]	M8	9 [0.35]	G1	135 [99]	380 [280]
25	100 [3.94]	130 [5.12]	56 [2.21]	M10	11 [0.43]	G1 1/4	480 [354]	500 [368]
30	100 [3.94]	130 [5.12]	65 [2.56]	M10	11 [0.43]	G1 1/2	560 [413]	600 [442]

NG	H1	H2	L1	L2	L3	L4	L5	L6	T1	T2	Weight, ca. in kg [lbs]
6	25 [0.98]	40 [1.57]	80 [3.15]	4 [0.16]	15 [0.59]	55 [2.17]	40 [1.57]	20 [0.79]	10 [0.39]	12 [0.47]	1.5 [3.3]
8	40 [1.57]	60 [2.36]	100 [3.94]	4 [0.16]	20 [0.79]	70 [2.76]	48 [1.89]	21 [0.83]	15 [0.59]	12 [0.47]	3.7 [8.2]
10	40 [1.57]	60 [2.36]	100 [3.94]	4 [0.16]	20 [0.79]	70 [2.76]	48 [1.89]	21 [0.83]	15 [0.59]	14 [0.55]	3.7 [8.2]
15	50 [1.97]	70 [2.76]	135 [5.32]	4 [0.16]	20 [0.79]	100 [3.94]	65 [2.56]	34 [1.34]	18 [0.71]	16 [0.63]	6.4 [14.1]
20	50 [1.97]	70 [2.76]	135 [5.32]	5.5 [0.22]	20 [0.79]	100 [3.94]	65 [2.56]	34 [1.34]	18 [0.71]	18 [0.71]	6.4 [14.1]
25	60 [2.36]	90 [3.54]	180 [7.09]	5.5 [0.22]	25 [0.98]	130 [5.12]	85 [3.35]	35 [1.38]	20 [0.79]	20 [0.79]	13.9 [30.6]
30	60 [2.36]	90 [3.54]	180 [7.09]	5.5 [0.22]	25 [0.98]	130 [5.12]	85 [3.35]	35 [1.38]	20 [0.79]	22 [0.87]	13.9 [30.6]

<sup>1)</sup> The tightening torques are standard values, referred to the maximum operating pressure and under the assumption that a torque wrench is used (tolerance  $\leq \pm 10\%$ ).

**Unit dimensions:** Cartridge valve (dimensions in mm [inch])

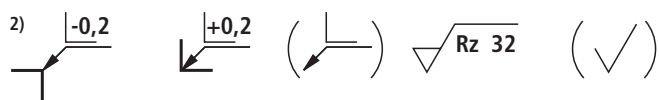
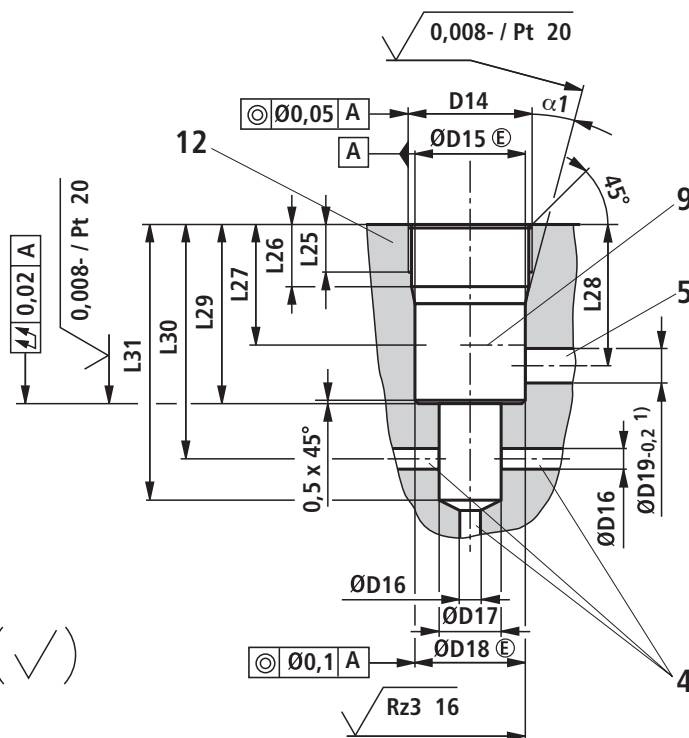
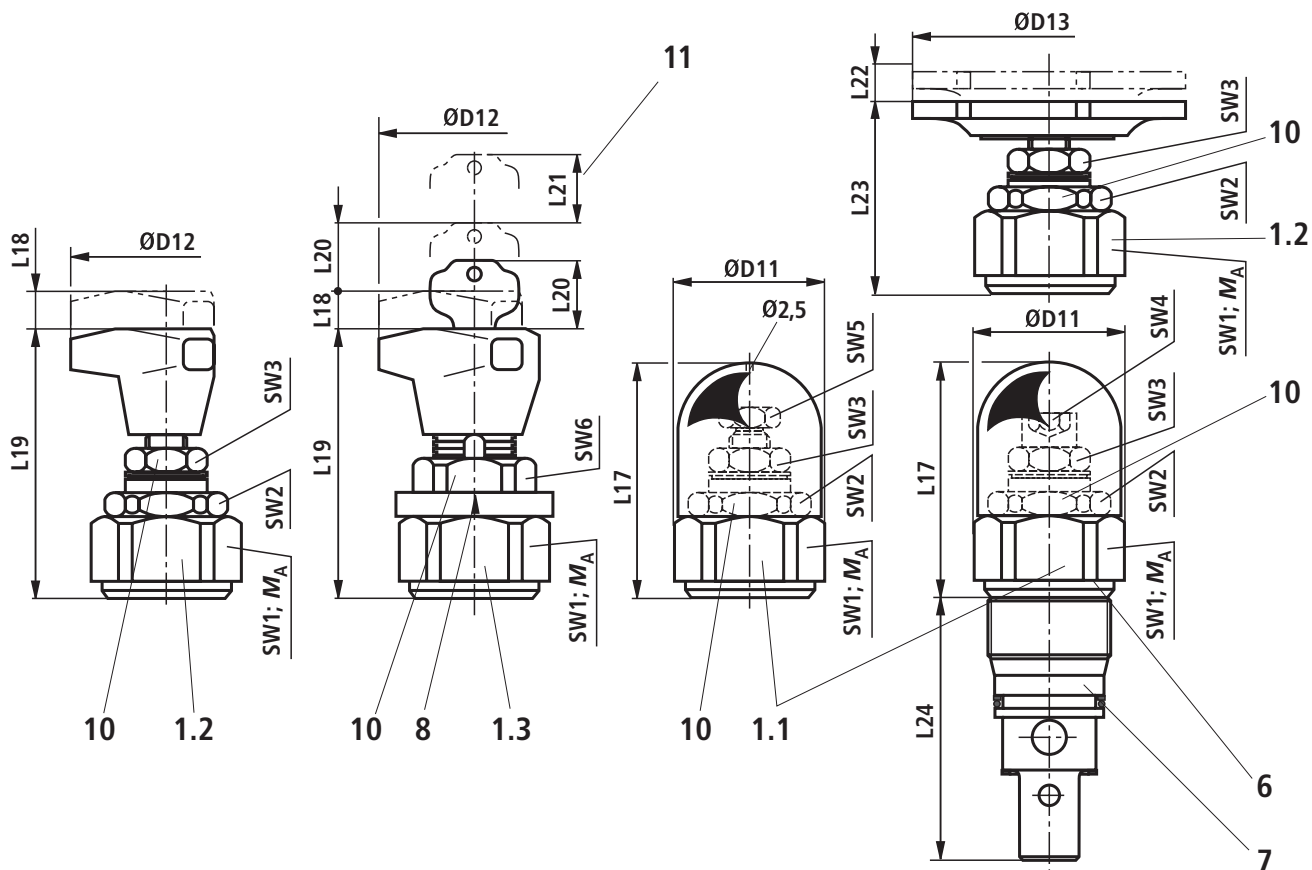

1) Maximum dimensions

2) All seal ring insertion faces are rounded and free from burrs

Tolerance for all angles  $\pm 0.5^\circ$

For dimensional tables and explanations of items, see page 9.

## Unit dimensions: Cartridge valve (dimensions in mm [inch])

### Cartridge valve

NG	ØD11	ØD12	ØD13	L17	L18	L19	L20	L21	L22	L23	L24
6	34 [1.34]	60 [2.36]	–	72 [2.83]	11 [0.43]	83 [3.26]	28 [1.10]	20 [0.79]	–	–	64.5 [2.54]
10	38 [1.50]	60 [2.36]	–	68 [2.68]	11 [0.43]	79 [3.11]	28 [1.10]	20 [0.79]	–	–	77 [3.03]
20	48 [1.89]	60 [2.36]	–	65 [2.56]	11 [0.43]	77 [3.03]	28 [1.10]	20 [0.79]	–	–	106 [4.17]
30	63 [2.48]	–	80 [3.15]	83 [3.26]	–	–	–	–	11 [0.43]	56 [2.21]	131 [5.16]

NG							Tightening torques $M_A$ in Nm [ft-lbs] for cartridge valves <sup>2)</sup>			Weight, ca. in kg [lbs]
	SW1	SW2	SW3	SW4	SW5	SW6	Pressure rating in bar [psi]			
							up to 200 [2900]	up to 400 [5800]	up to 630 [9150]	
6	32	30	19	6	–	30	50±5 [37±3.7]	80±5 [59±4]	–	0.4 [0.88]
10	36	30	19	6	–	30	100±5 [74±3.5]	150±10 [110±3.5]	200±10 [148±7.5]	0.5 [1.10]
20	46	36	19	6	–	30	150±10 [111±7.5]	300±15 [221±11]	–	1 [2.21]
30	60	46	19	–	13	–	350±20 [258±19.5]	500±30 [369±22]	–	2.2 [4.85]

<sup>2)</sup> The tightening torques are recommended values assuming a friction coefficient of ca. 0.12 and the use of a torque wrench.

### Mounting cavity

NG	D14	ØD15	ØD16	ØD17	ØD18	ØD19
6	M28 x 1.5	25H9 [0.9843+0.002]	6 [0.24]	15 [0.59]	24.9 <sup>+0.152</sup> <sub>-0.2</sub> [0.9803] <sup>[+0.006]</sup> <sub>[-0.00786]</sub>	12 [0.47]
10	M35 x 1.5	32H9 [1.2598+0.0024]	10 [0.39]	18.5 [0.73]	31.9 <sup>+0.162</sup> <sub>-0.2</sub> [1.2559] <sup>[+0.0064]</sup> <sub>[-0.0079]</sub>	15 [0.59]
20	M45 x 1.5	40H9 [1.5748+0.0024]	20 [0.79]	24 [0.95]	39.9 <sup>+0.162</sup> <sub>-0.2</sub> [1.5709] <sup>[+0.0063]</sup> <sub>[-0.0079]</sub>	22 [0.87]
30	M60 x 2	55H9 [2.1654+0.0029]	30 [1.18]	38.75 [1.53]	54.9 <sup>+0.174</sup> <sub>-0.2</sub> [2.1614] <sup>[+0.0069]</sup> <sub>[-0.0079]</sub>	34 [1.34]

NG	L25	L26	L27	L28	L29	L30	L31	α1
6	15 [0.59]	19 [0.75]	30 [1.18]	36 [1.42]	45 [1.77]	56.5±5.5 [2.22±0.217]	65 [2.56]	15°
10	18 [0.71]	23 [0.91]	35 [1.38]	41.5 [1.63]	52 [2.05]	67.5±7.5 [2.66±0.295]	80 [3.15]	15°
20	21 [0.83]	27 [1.06]	45 [1.77]	55 [2.17]	70 [2.76]	91.5±8.5 [3.60±0.335]	110 [4.33]	20°
30	23 [0.91]	29 [1.14]	45 [1.77]	63 [2.48]	84 [3.31]	113.5±11.5 [4.47±0.453]	140 [5.51]	20°

- 1.1 Adjustment element "S" – set screw with hexagon and protective cap; hexagon socket (up to NG20), hexagon head (NG30)
- 1.2 Adjustment element "H" – rotary knob (up to NG20), hand wheel (NG30)
- 1.3 Adjustment element "A" – lockable rotary knob up to NG10 (NG20 to 100 bar [1450 psi])
- 4 Port P, optional, on the circumference or front face
- 5 Port T, optional, on the circumference
- 6 Type designation
- 7 Pressure rating (impressed)
- 8 Marking (adjustment of the zero position after the valve was screwed in; then securing of the ring by shifting it horizontally until the plug screw locks into position on the 6 A/F plug screw)
- 9 Depth of fit
- 10 Locknut, tightening torque  $M_T = 10^{+5}$  Nm [7.4<sup>+3.7</sup> ft-lbs]
- 11 Space required to remove key
- 12 Minimum strength of housing materials, see Technical data on page 5

**Unit dimensions:** Subplate mounting (dimensions in mm [inch])

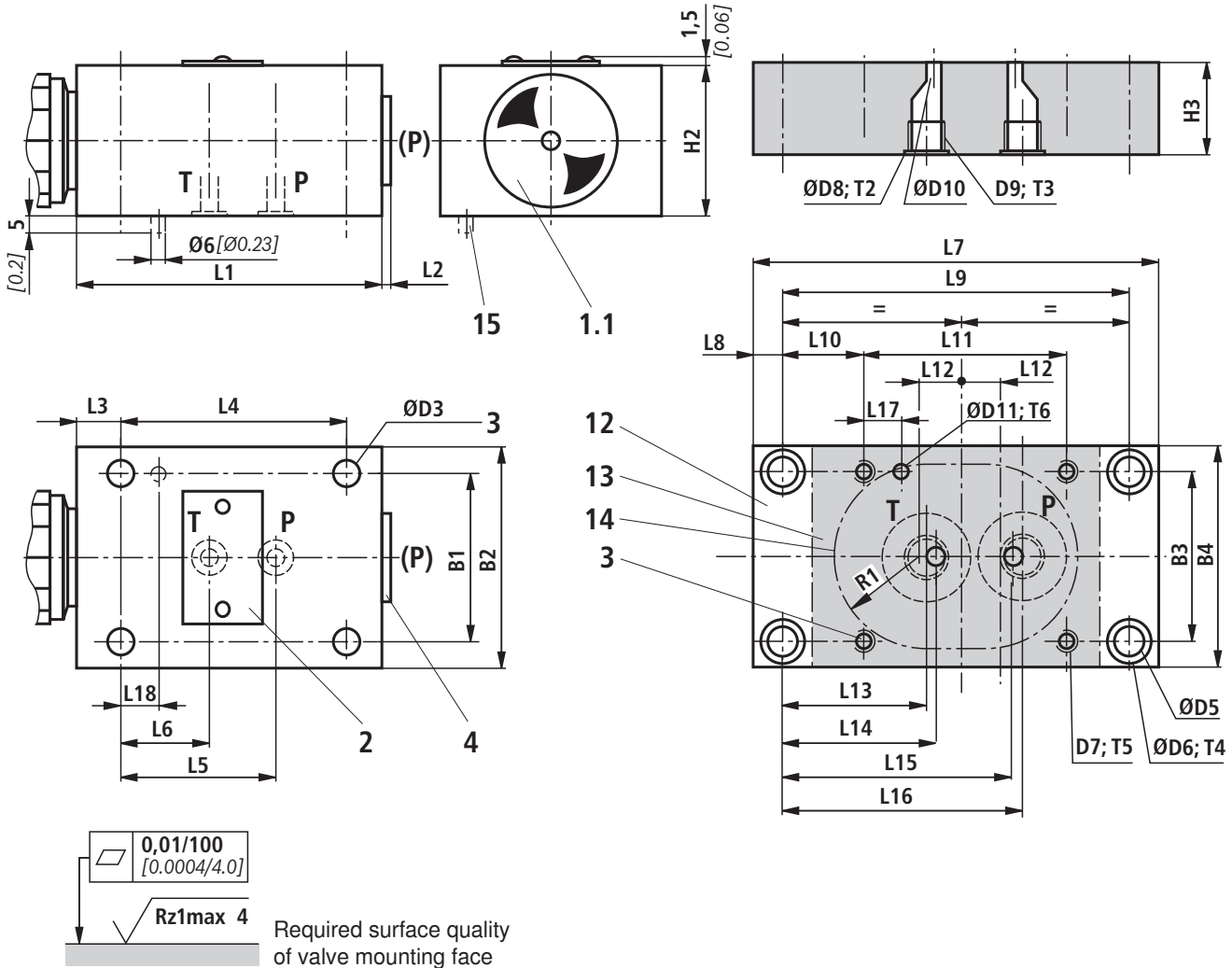

For versions and dimensions of the adjustment elements, see pages 8 and 9.

For strength reasons, use exclusively the following valve mounting screws (separate order):

4 hexagon socket head cap screws ISO 4762 - flZn-240h-L <sup>1)</sup>  
(friction coefficient  $\mu_{total} = 0.09$  to  $0.14$ )

NG	Dimension	Strength class	$M_T$ in Nm [ft-lbs] <sup>2)</sup>	Material number
6	M6 x 50	10.9	12,5 [9.2]	R913000151
10	M8 x 70	10.9	28 [20.7]	R913000149
20	M8 x 90	12.9	28 [20.7]	R913000150
30	M10 x 110	12.9	56 [41.3]	R913000148

4 hexagon socket head cap screws UNC on request

- 1.1 Adjustment element "S" (example)  
Set screw with hexagon and protective cap; hexagon socket (up to NG20), hexagon head (NG30)
- 2 Nameplate
- 3 4 valve mounting bores
- 4 Additional port (P), optional (e.g. for pressure measurement); not possible for NG10, pressure rating > 400 bar (= version "SO292"). For tightening torques, see table of dimensions on page 7)
- 12 Subplate (for type designation, see table on page 11)
- 13 Valve mounting face
- 14 Front panel cutout
- 15 Locating pin (only on type-tested safety valves)

<sup>1)</sup> Alternatively, bolts appropriately specified in accordance with DIN 912 can be used.

<sup>2)</sup> For tightening, use a torque wrench having a tolerance of ≤10%.

**Unit dimensions: Subplate mounting (dimensions in mm [inch])****Pressure relief valve**

NG	B1	B2	ØD3	H2	L1	L2	L3
6	45 [1.77]	60 [2.36]	6.6 [0.26]	40 [1.57]	80 [3.15]	4 [0.16]	15 [0.59]
10	60 [2.36]	80 [3.15]	9 [0.35]	60 [2.36]	100 [3.94]	4 [0.16]	20 [0.79]
20	70 [2.76]	100 [3.94]	9 [0.35]	70 [2.76]	135 [5.32]	5.5 [0.22]	20 [0.79]
30	100 [3.94]	130 [5.12]	11 [0.43]	90 [3.54]	180 [7.09]	5.5 [0.22]	25 [0.98]

NG	L4	L5	L6	L18	Port (P)	Weight, ca. in kg [lbs]
6	55 [2.17]	40 [1.57]	20 [0.79]	15 [0.59]	G1/4	1.5 [3.3]
10	70 [2.76]	45 [1.77]	21 [0.83]	15 [0.59]	G1/2	3.7 [8.2]
20	100 [3.94]	65 [2.56]	34 [1.34]	15 [0.59]	G3/4	6.4 [14.1]
30	130 [5.12]	85 [3.35]	35 [1.37]	15 [0.59]	G1 1/4	13.9 [30.6]

**Subplates <sup>3)</sup>**

NG	Type	B3	B4	ØD5	ØD6	D7	ØD8	D9
6	G300/01 [G300/12]	45 [1.77]	60 [2.36]	6.6 [0.26]	11 [0.43]	M6 [1/4-20 UNC]	25 [0.98]	G1/4 [SAE 4; 7/16-20]
10	G661//01	60 [2.36]	80 [3.15]	6.6 [0.26]	11 [0.43]	M8	25 [0.98]	G3/8
	G662/01	60 [2.36]	80 [3.15]	6.6 [0.26]	11 [0.43]	M8	34 [1.34]	G1/2
20	G303/01	70 [2.76]	100 [3.94]	11 [0.43]	18 [0.71]	M8	42 [1.65]	G3/4
	G304/01	70 [2.76]	100 [3.94]	11 [0.43]	18 [0.71]	M8	47 [1.85]	G1
30	G305/01	100 [3.94]	130 [5.12]	11 [0.43]	18 [0.71]	M10	56 [2.20]	G1 1/4
	G306/01	100 [3.94]	130 [5.12]	11 [0.43]	18 [0.71]	M10	65 [2.56]	G1 1/2

NG	ØD10	ØD11	H3	L7	L8	L9	L10	L11	L12
6	6 [0.24]	8 [0.32]	25 [0.98]	110 [4.33]	8 [0.32]	94 [3.70]	22 [0.87]	55 [2.17]	10 [0.39]
10	10 [0.39]	8 [0.32]	25 [0.98]	135 [5.32]	10 [0.39]	115 [4.53]	27.5 [1.08]	70 [2.76]	12.5 [0.49]
	10 [0.39]	8 [0.32]	25 [0.98]	135 [5.32]	10 [0.39]	115 [4.53]	27.5 [1.08]	70 [2.76]	12.5 [0.49]
20	15 [0.59]	8 [0.32]	40 [1.57]	170 [6.69]	15 [0.59]	140 [5.51]	20 [0.79]	100 [3.94]	20 [0.79]
	20 [0.79]	8 [0.32]	40 [1.57]	170 [6.69]	15 [0.59]	140 [5.51]	20 [0.79]	100 [3.94]	20 [0.79]
30	30 [1.18]	8 [0.32]	40 [1.57]	190 [7.48]	12.5 [0.49]	165 [6.50]	17.5 [0.67]	130 [5.12]	22.5 [0.89]

NG	L13	L14	L15	L16	L17	T2	T3	T4	T5
6	39 [1.54]	42 [1.65]	62 [2.44]	65 [2.56]	15 [0.59]	1 [0.039]	15 [0.59]	9 [0.35]	15 [0.59]
10	40.5 [1.59]	48.5 [1.91]	72.5 [2.85]	80.5 [3.17]	15 [0.59]	1 [0.039]	15 [0.59]	9 [0.35]	12 [0.47]
	40.5 [1.59]	48.5 [1.91]	72.5 [2.85]	80.5 [3.17]	15 [0.59]	1 [0.039]	16 [0.63]	9 [0.35]	15 [0.59]
20	45 [1.77]	54 [2.13]	85 [3.35]	94 [3.70]	15 [0.59]	1 [0.039]	20 [0.79]	13 [0.51]	22 [0.87]
	42 [1.65]	54 [2.13]	85 [3.35]	97 [3.82]	15 [0.59]	1 [0.039]	20 [0.79]	13 [0.51]	22 [0.87]
30	42 [1.65]	52.5 [2.07]	102.5 [4.04]	113 [4.45]	15 [0.59]	1 [0.039]	24 [0.95]	11.5 [0.45]	22 [0.87]

NG	T6	R1	Weight, ca. in kg [lbs]
6	6 [0.24]	25 <sup>+2</sup> [0.98 <sup>+0.079</sup> ]	1.5 [3.3]
10	6 [0.24]	30 <sup>+5</sup> [1.18 <sup>+0.197</sup> ]	2 [4.4]
20	6 [0.24]	40 <sup>+3</sup> [1.57 <sup>+0.118</sup> ]	5.5 [12.1]
30	6 [0.24]	55 <sup>+4</sup> [2.16 <sup>+0.157</sup> ]	8 [17.6]

**<sup>3)</sup> Attention!**

The subplates listed are **not** approved for use with type-tested safety valves according to Pressure Equipment Directive 97/23/EC!

**Ordering code:** Type-tested safety valves of type DBD <sup>1)</sup>

NG	Type designation	Component code
6	DBDS 6K1X/ <input type="checkbox"/> E	TÜV.SV.□-849.5.F. $\alpha_w$ .p. G
	DBDH 6K1X/ <input type="checkbox"/> E	
	DBDS 6G1X/ <input type="checkbox"/> E	
	DBDH 6G1X/ <input type="checkbox"/> E	
	DBDS 6P1X/ <input type="checkbox"/> E	
	DBDH 6P1X/ <input type="checkbox"/> E	
10	DBDS 10K1X/ <input type="checkbox"/> E	TÜV.SV.□-850.6.F. $\alpha_w$ .p. G
	DBDH 10K1X/ <input type="checkbox"/> E	
	DBDS 10G1X/ <input type="checkbox"/> E	TÜV.SV.□-390.4,5.F.30.p. <sup>2)</sup>
	DBDH 10G1X/ <input type="checkbox"/> E	
	DBDS 10P1X/ <input type="checkbox"/> E	
	DBDH 10P1X/ <input type="checkbox"/> E	

NG	Type designation	Component code
20	DBDS 20K1X/ <input type="checkbox"/> E	TÜV.SV.□-361.10.F. $\alpha_w$ .p.
	DBDH 20K1X/ <input type="checkbox"/> E	
	DBDS 20G1X/ <input type="checkbox"/> E	
	DBDH 20G1X/ <input type="checkbox"/> E	
	DBDS 20P1X/ <input type="checkbox"/> E	
	DBDH 20P1X/ <input type="checkbox"/> E	
30	DBDS 30K1X/ <input type="checkbox"/> E	
	DBDH 30K1X/ <input type="checkbox"/> E	
	DBDS 30G1X/ <input type="checkbox"/> E	
	DBDH 30G1X/ <input type="checkbox"/> E	
	DBDS 30P1X/ <input type="checkbox"/> E	
	DBDH 30P1X/ <input type="checkbox"/> E	

- The customer must enter the pressure in the type designation; pressure settings are possible  $\geq 30$  bar [435 psi] and in 5-bar [72 psi] increments.
- Details are entered in the factory

- <sup>1)</sup> Component series 1X, to Pressure Equipment Directive 97/23/EC
- <sup>2)</sup> Component code for DBD. 10.1X/...; 400 bar [5801 psi] < p ≤ 630 bar [9150 psi]

**Unit dimensions:** Sheet metal cutout for front panel installation of type-tested safety valves of type DBD <sup>1)</sup> (dimensions in mm [inch])

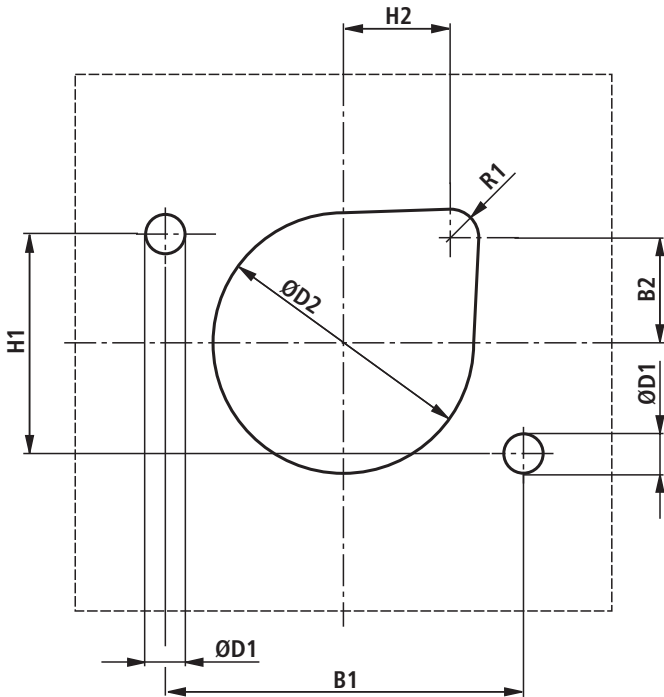

NG	B1	B2	H1	H2
6	45 [1.77]	12.5 [0.49]	25 [0.98]	22.5 [0.89]
10	60 [2.36]	20.5 [0.81]	40 [1.57]	20.5 [0.81]
20	70 [2.76]	24 [0.94]	50 [1.97]	24 [0.94]
30	100 [3.94]	29.5 [1.16]	60 [2.36]	29.5 [1.16]

NG	ØD1H13	ØD2H13	R1
6	7 [0.27]	40 [1.57]	8 [0.32]
10	9 [0.35]	44 [1.73]	8 [0.32]
20	9 [0.35]	55 [2.17]	8 [0.32]
30	11 [0.43]	73 [2.87]	8 [0.32]

**Note!**  
For valves of type DBDH.K..1X/..E the hand wheel must be removed and then refitted before the cartridge valve can be mounted on the valve panel.

<sup>1)</sup> Component series 1X, to Pressure Equipment Directive 97/23/EC

## Deviating technical data: Type-tested safety valves of type DBD <sup>1)</sup>

### Hydraulic

Maximum flow	See characteristic curves on pages 13 to 16
Hydraulic fluid	Mineral oil (HL, HLP) to DIN 51524-1 and DIN 51524-2
Hydraulic fluid temperature range	°C [°F] -20 to +60 [-4 to +140] (NBR seals) -15 to +60 [5 to 140] (FKM seals)
Viscosity range	mm <sup>2</sup> /s [SUS] 12 to 230 [55 to 1066]

<sup>1)</sup> Component series 1X, to Pressure Equipment Directive 97/23/EC (for applications outside these parameters, please consult us!)

## Characteristic curves: Type-tested safety valves of type DBD <sup>1)</sup>

<sup>1)</sup> Component series 1X, according to Pressure Equipment Directive 97/23/EC

**Note!**

Values within the gray-shaded sections of the characteristic curves cannot be achieved with this valve!

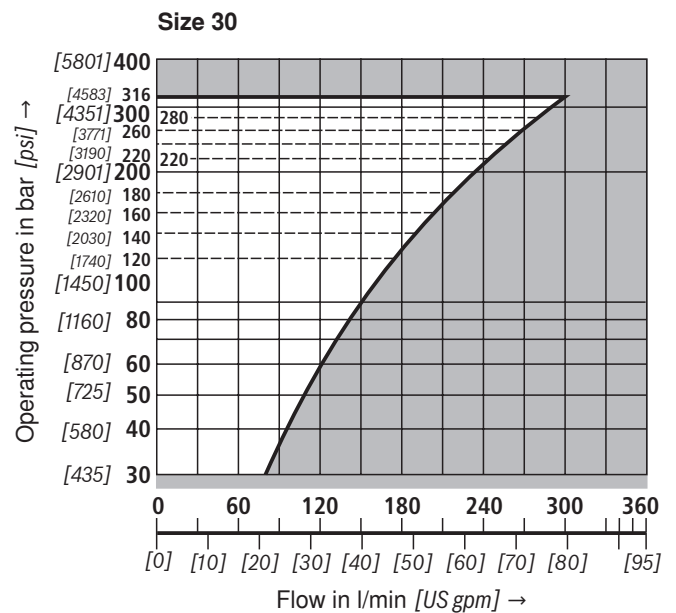
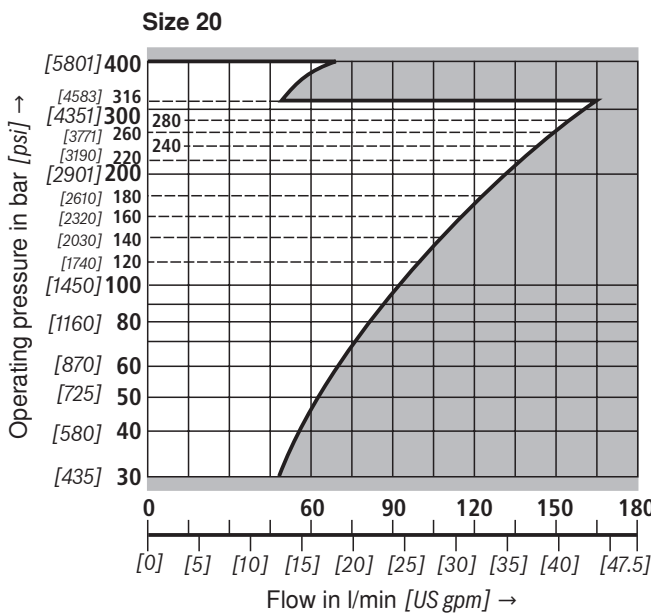
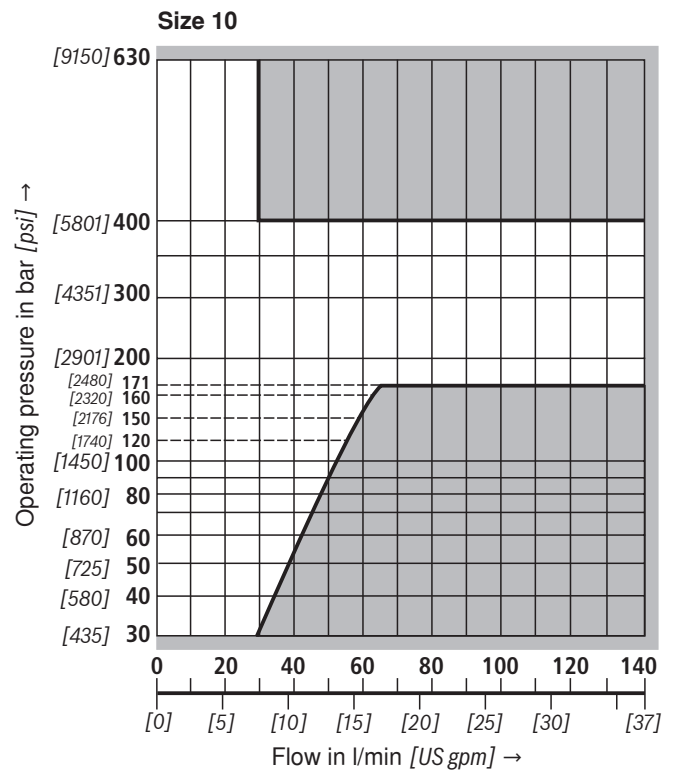
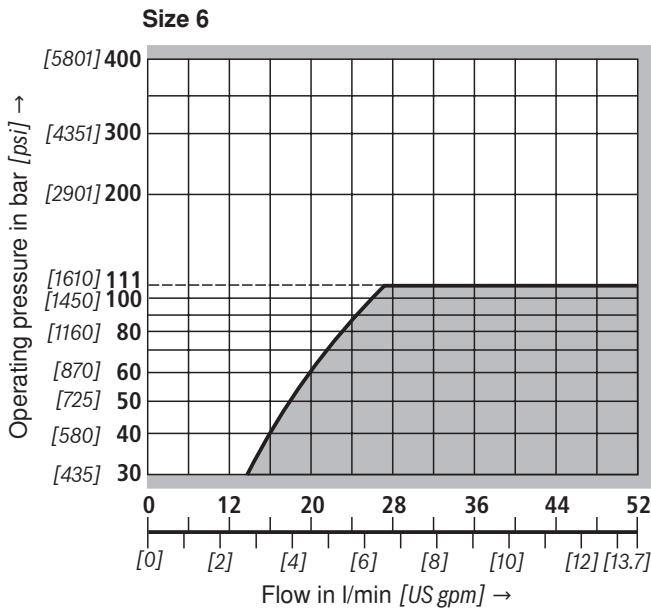

**Safety notes:** Type-tested safety valves of type DBD <sup>1)</sup>

- Before ordering a type-tested safety valve, please note that at the desired **response pressure p** the permissible maximum flow **q<sub>vmax</sub>** of the safety valve is greater than the permissible maximum flow of the system / accumulator to be protected.

The relevant regulations must be observed!

- According to **PED 97/23/EC** the increase in the system pressure caused by the flow must not exceed 10 % of the set response pressure (see component code).

The permissible maximum flow **q<sub>vmax</sub>** specified in the component code must not be exceeded.

Drain lines of safety valves must terminate without any risks. **No** fluid may accumulate in the drain system (see AD2000 - sheet A2).



**Strictly observe notes on the operation!**

- The response pressure specified in the component code is factory-set at a flow of 2 l/min [0.53 US gpm].
- The permissible maximum flow specified in the component code is valid for applications without backpressure in the drain line (port T).
- When the lead-seal is removed from the safety valve, the approval in accordance with PED becomes void!
- Generally, the requirements laid down in the Pressure Equipment Directive and in AD2000 sheet A2 must be observed!
- It is recommended that type-tested safety valves be secured against unauthorized removal from the housing/block by means of wires and lead-sealing (a bore is provided in the adjustment element).

**Attention!**

As the flow rises, the system pressure increases by the backpressure in the drain line (port T). (Observe AD2000 - sheet A2, section 6.3!)

In order that this increase in the system pressure caused by the flow will not exceed 10 % of the set response pressure, the permissible flow must be reduced in dependence upon the backpressure in the drain line (port T) (see diagrams on pages 14 to 16).

Permissible maximum flow **q<sub>vmax</sub>** in dependence upon backpressure **p<sub>T</sub>** in the drain line

Type DBD. 6 .1X/...E

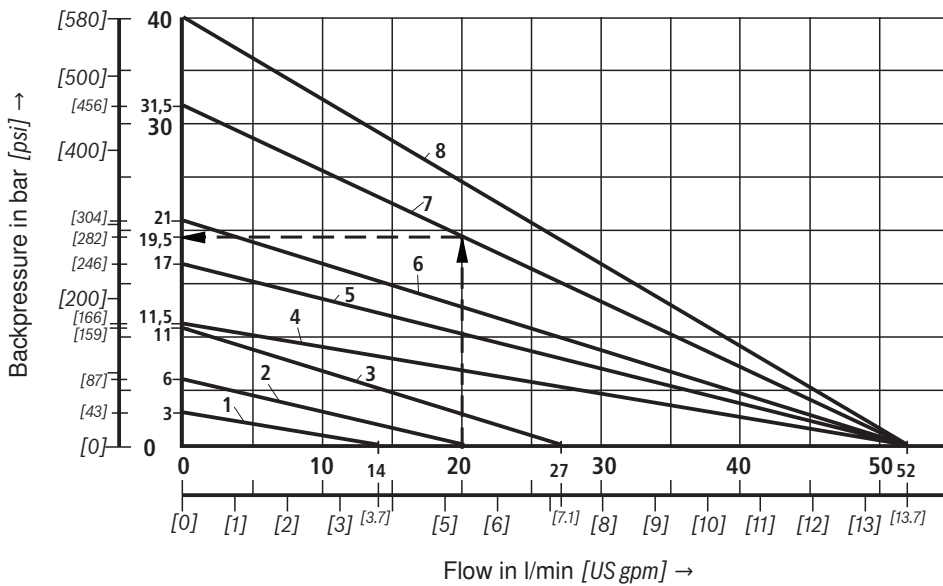

Characteristic curves	Response pressure <b>p<sub>A</sub></b> in bar [psi]
1	30 [435]
2	60 [870]
3	110 [1595]
4	115 [1668]
5	170 [2465]
6	210 [3046]
7	315 [4568]
8	400 [5800]

Characteristic curves for intermediate values can be generated by interpolation. Further explanations can be found on page 16.

<sup>1)</sup> Component series 1X, to Pressure Equipment Directive 97/23/EC

**Safety notes:** Type-tested safety valves of type DBD <sup>1)</sup>

Permissible maximum flow  $q_{Vmax}$  in dependence upon backpressure  $p_T$  in the drain line

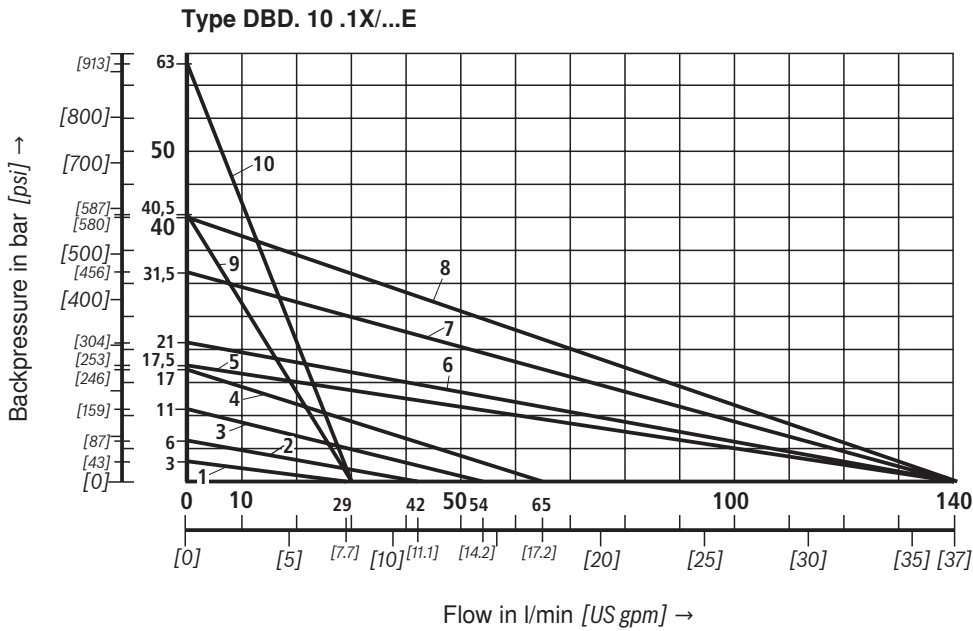

Characteristic curves	Response pressure $p_A$ in bar [psi]
1	30 [435]
2	60 [870]
3	110 [1595]
4	170 [2465]
5	175 [2538]
6	210 [3046]
7	315 [4568]
8	400 [5800]
9	405 [5874]
10	630 [9150]

Characteristic curves for intermediate values can be generated by interpolation. Further explanations can be found on page 16.

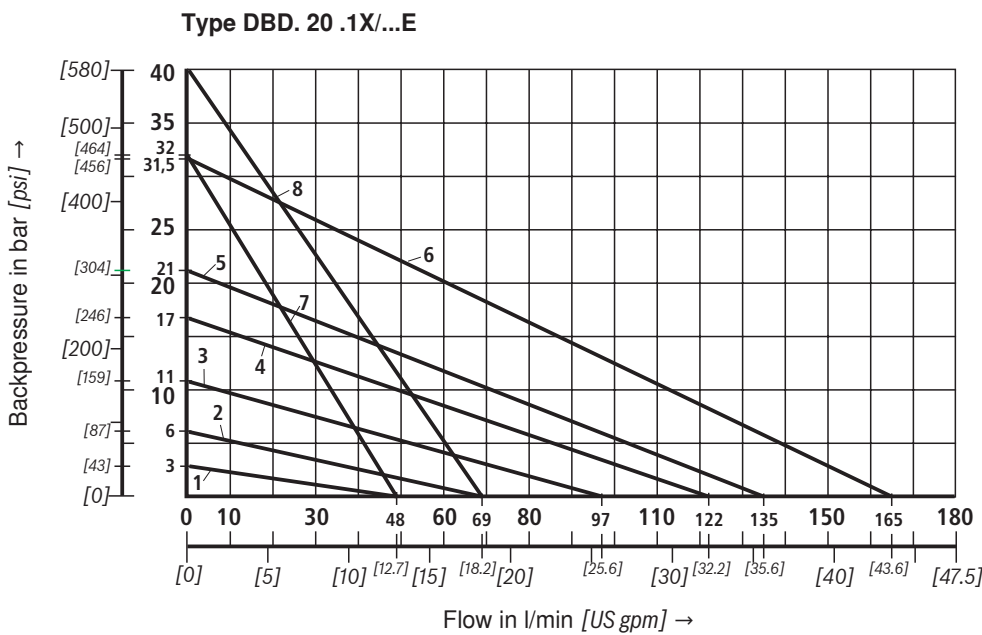

Characteristic curves	Response pressure $p_A$ in bar [psi]
1	30 [435]
2	60 [870]
3	110 [1595]
4	170 [2465]
5	210 [3046]
6	315 [4568]
7	320 [4641]
8	400 [5800]

Characteristic curves for intermediate values can be generated by interpolation. Further explanations can be found on page 16.

<sup>1)</sup> Component series 1X, to Pressure Equipment Directive 97/23/EC

**Safety notes:** Type-tested safety valves of type DBD <sup>1)</sup>

Permissible maximum flow  $q_{Vmax}$  in dependence upon backpressure  $p_T$  in the drain line

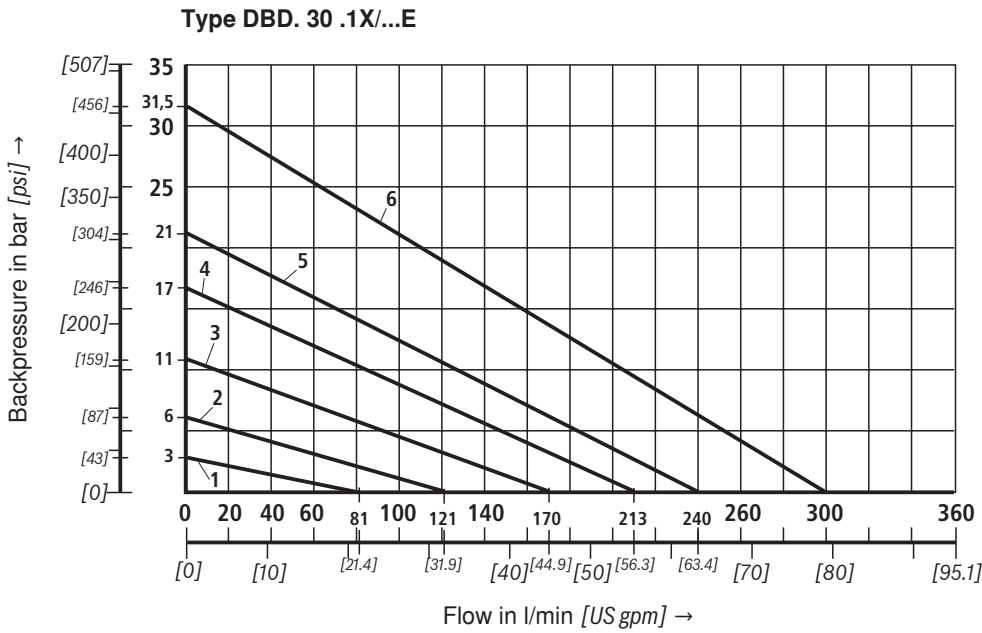

Characteristic curves	Response pressure $p_A$ in bar [psi]
1	30 [435]
2	60 [870]
3	110 [1595]
4	170 [2465]
5	220 [3191]
6	315 [4568]

Characteristic curves for intermediate values can be generated by interpolation. For further explanations, see below.

$p_A$  = response pressure in bar

$p_T$  = permissible maximum backpressure in bar (sum of all tank pressures; see also AD2000 - sheet A2)

$q_{Vmax}$  = permissible maximum flow in l/min

**PED:**  $p_{Tmax} = 10\% \times p_A$  (at  $q_V = 0$ )

**Explanation of diagrams** (Example: type DBD 6 ...E, page 14):

- Given: – flow of the system/accumulator to be protected  $q_{Vmax} = 20$  l/min
- set response pressure of the safety valve  $p_A = 315$  bar

Sought:  $p_{T permissible}$

**Solution:** See arrows in the diagram on page 14 (type DBD 6 ...E)  
 $p_{T permissible} (20 \text{ l/min}; 315 \text{ bar}) = 19.5 \text{ bar}$

<sup>1)</sup> Component series 1X, to Pressure Equipment Directive 97/23/EC